



ZTVC

DC INVERTER VRF SYSTEM
Product Catalogue



ZERO | ZTVC

Web: www.zerohvacr.com



Production Capacity

Robotic Assembly Arm



Automatic Packing Robot



AGV System



MES System



Quality Superiority



Certification

ISO9001 quality management system, ISO14001 environmental management system, OHSAS18001 occupational health and safety management system, QC080000 electronic and electrical components and products harmful substances process management system certification

Main product certificated by CCC, energy-saving certification, ETL, AHRI, DOE, CE, CB, SASO, ESMA, MEW and others.





Enthalpy Difference Lab



Laboratory Control Room

R&D Strength



200kg Transport Simulation Platform



Professional Engineers



EMC Lab



Noise Test Lab



200HP Long-term Running Lab



Modular Chiller Test Lab



Electromagnetic Vibration Lab

Directory

- 01 • Overview
- 02 • ZTVC
- 21 • Specifications
- 27 • ZTVC-Mini
- 34 • Specifications
- 35 • Indoor Units
- 56 • Controller and Software
- 61 • Projects

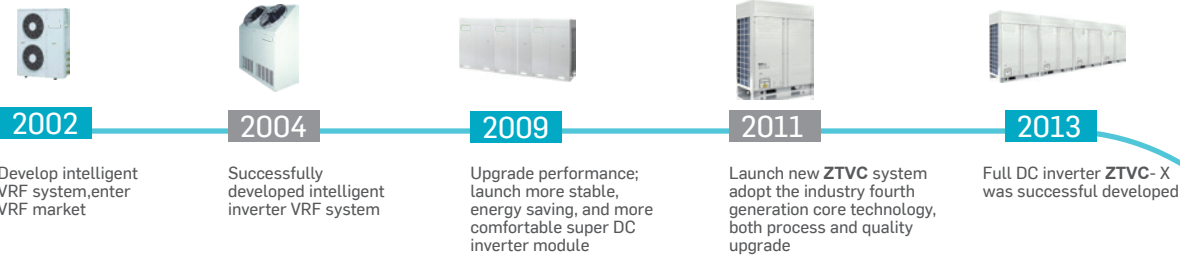

VRF Development History

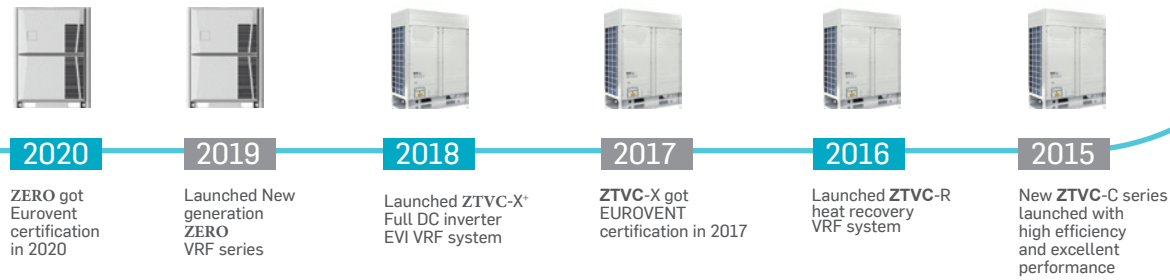

How To Read The Model Name

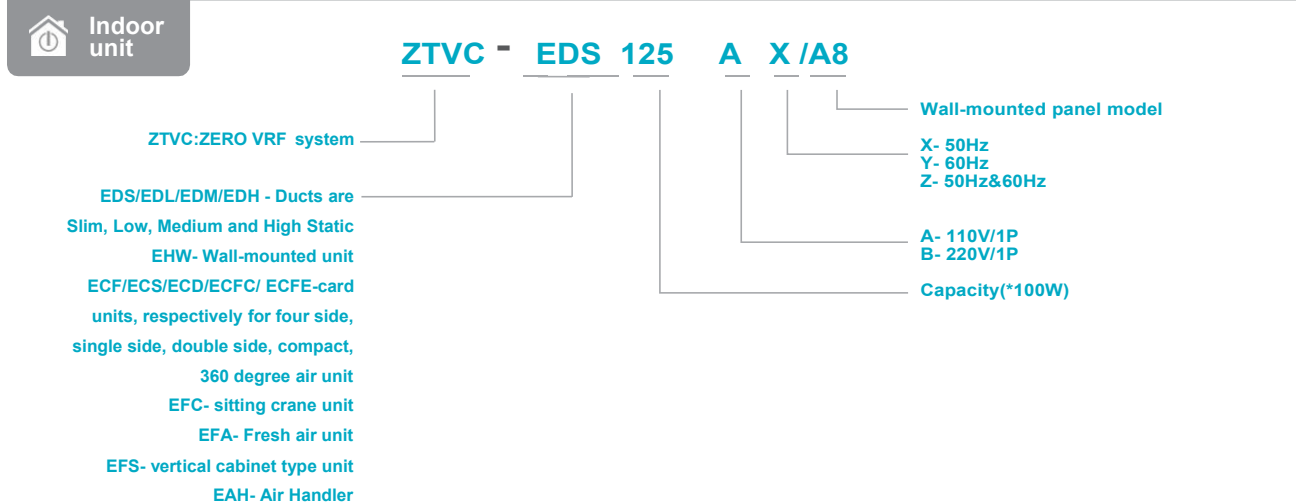
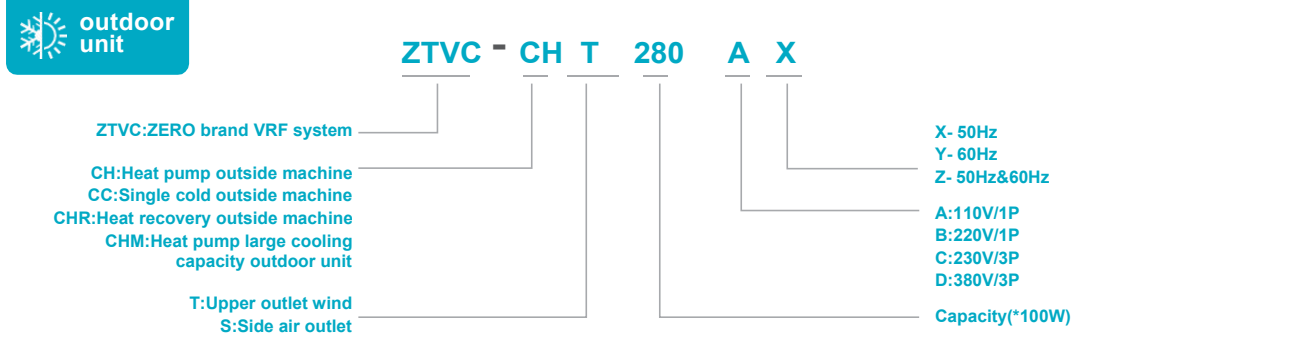

ZTVC New Generation Full DC Inverter VRF System

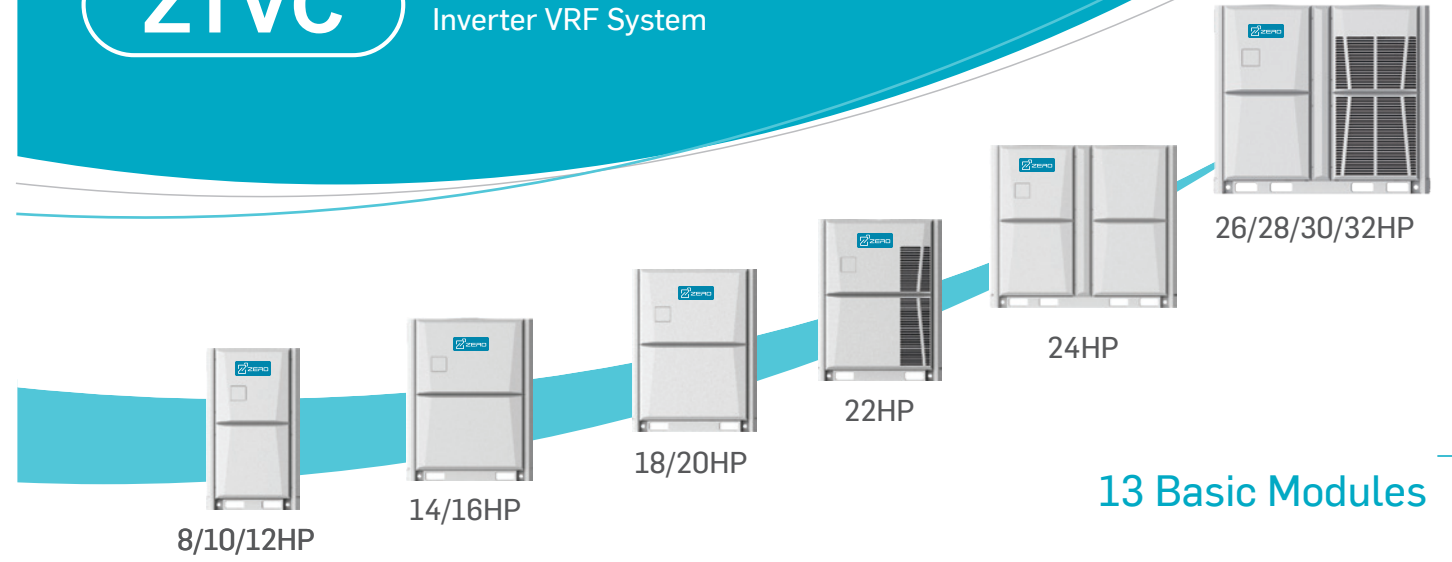

Capacity	8HP	10HP	12HP	14HP	16HP	18HP	20HP	22HP	24HP	26HP	28HP	30HP	32HP
	25.2kW	28kW	33.5kW	40kW	45kW	50kW	56kW	61.5kW	67kW	73kW	78.5kW	85kW	90kW
Compressor	DC	DC	DC	DC	DC	DC	DC	DC	DC+DC	DC+DC	DC+DC	DC+DC	DC+DC
Fan motor	DC	DC	DC	DC	DC	DC+DC	DC+DC	DC+DC	DC+DC	DC+DC	DC+DC	DC+DC	DC+DC

EER&COP

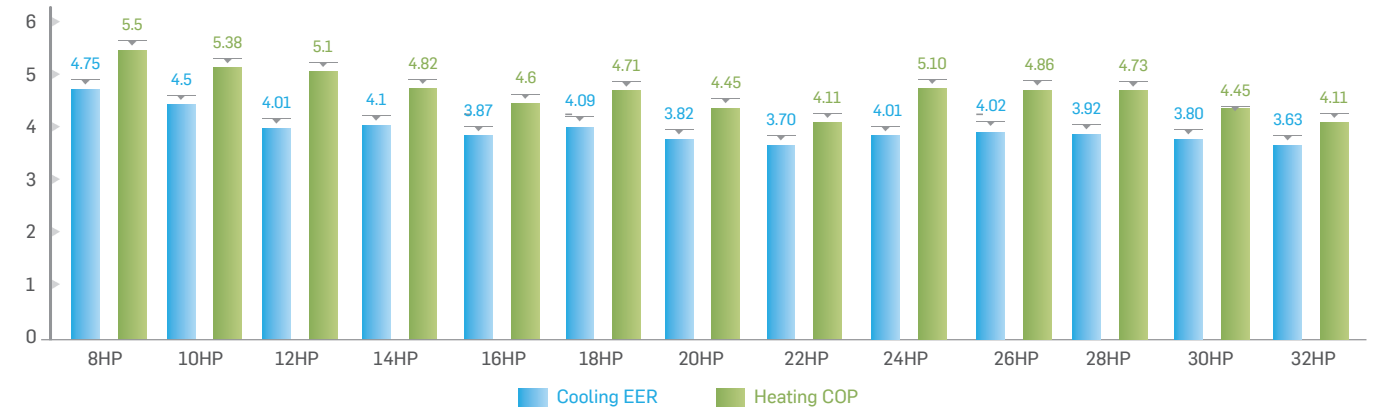

IPLV(C)

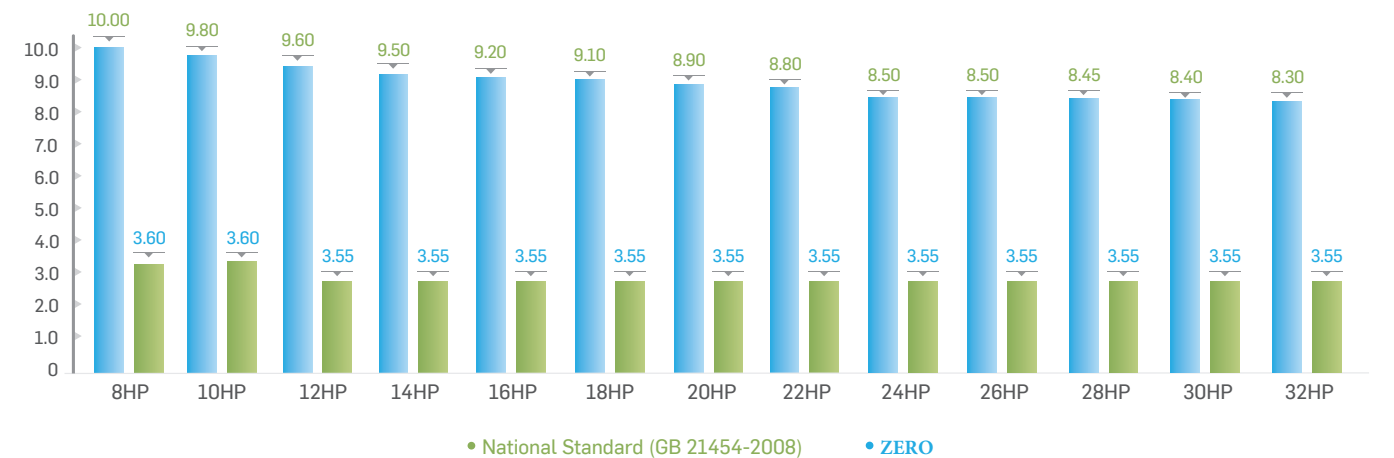

Combination Table

HP	Cooling Cap.(kW)	8HP	10HP	12HP	14HP	16HP	18HP	20HP	22HP	24HP	26HP	28HP	30HP	32HP
8	25.2	●												
10	28		●											
12	33.5			●										
14	40				●									
16	45					●								
18	50						●							
20	56							●						
22	61.5								●					
24	67									●				
26	73										●			
28	78.5											●		
30	85												●	
32	90													●
34	95					●	●							
36	100						●	●						
38	106.5					●		●	●					
40	111.5						●		●	●				
42	117.5							●		●	●			
44	123								●	●	●			
46	128.5									●	●	●		
48	134										●	●		
50	140											●	●	
52	145.5												●	●
54	152													●
56	157													●
58	163													●
60	168.5													●
62	175													●
64	180													●
66	184.5								●	●	●			●
68	190									●	●	●		●
70	195.5										●	●	●	●
72	201.5											●	●	●
74	207												●	●
76	212.5													●
78	218.5													●
80	224													●
82	230													●
84	235.5													●
86	242													●
88	247													●
90	253													●
92	258.5													●
94	265													●
96	270													●

*Note:Max.4 outdoor units can be freely combined to become a larger unit, the maximum capacity of single system is 96HP, when 4 outdoor units are combined, the single unit capacity can not exceed 24HP.

Long Piping & Height Difference

The total pipe length	1000 m
The longest pipe length	200 /240m
Height difference	Outdoor unit above <100m Outdoor unit below <110m
Height difference between indoor units	40m
Length from first indoor distributor to last indoor unit	90 m
Communication wire length	can be up to 1000m.

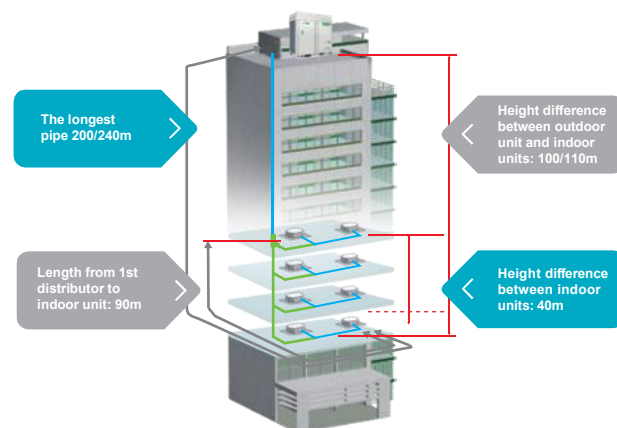

Features

Long Distance Remote Control
Long distance remote control by phone or tablet.

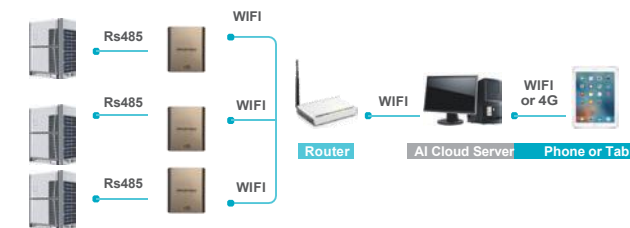

Malfunction Forecasting

- Thanks to the AI cloud server, malfunction can be forecasted when system running parameter is abnormal.
- Technician can be sent to site to check the system before it stops.

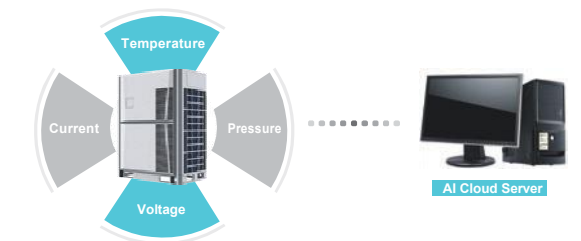

Refrigerant Cooling Design

We use refrigerant to cool down inverter modular board to keep it in a safe condition even when outdoor temperature is up to 55°C.



Wide Outdoor Operation Range

- Due to EVI technology, ZTVc heating performance increased by 35% compare to conventional VRF system.
- Due to EVI technology, ZTVc still has 85% of rated capacity even in -15°C.

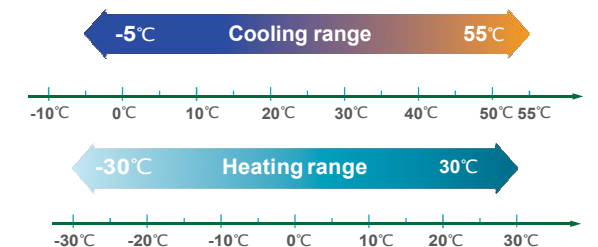

Power Saving Mode

In the case of power shortage, ZTVc can run power saving mode to ease generator's pressure.

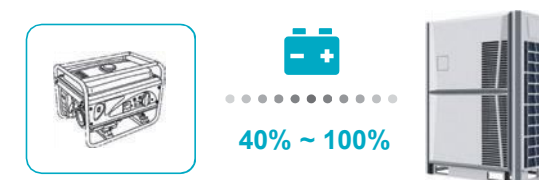

Refrigerant Status Detection

- Built-in with smart refrigerant auto check function, which can give suggestion about refrigerant status.
- Different code means different refrigerant status:

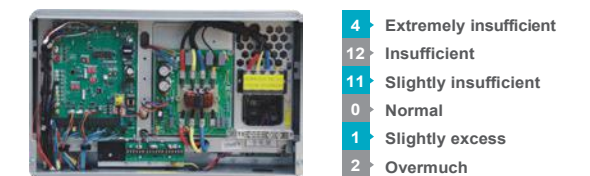

Features

② More indoor units

Max. 100 Indoor units can be connect in ONE system.

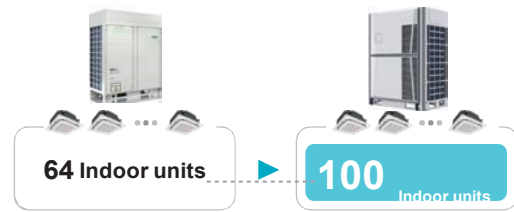

🔒 Electrical Lock Function(optional)



In case of end user doesn't pay as contract, electrical lock function can be used to stop VRF system, and end user can not start the system without permission.

System can be unlock with password by authorized technician.

📶 Wireless Communication(optional)

Wireless communication between indoor units.
Wireless communication between indoor unit and outdoor unit.

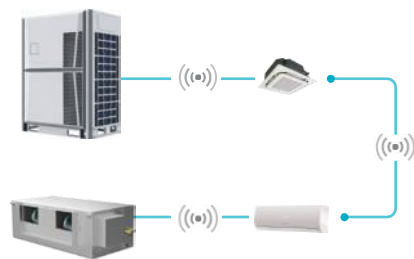

👨‍🔧 On Site Diagnosis

Technician can do the commissioning & diagnosis by phone or tablet on site.

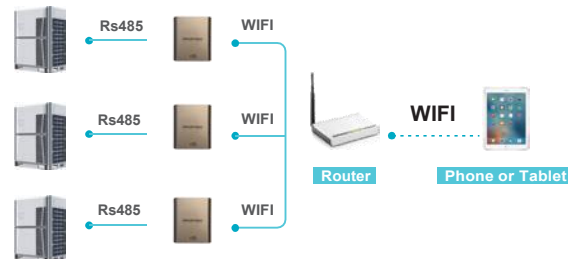

👋 Service Window On Front Cover

Thanks to the service window, checking outdoor units status and setting is now easy, no need to remove the front cover.



🔄 Auto Charging Refrigerant(optional)

ZTVC can customize with auto refrigerant charging function, additional solenoid valve will be added in gas pipe, and outdoor unit will control the valve to charge refrigerant.

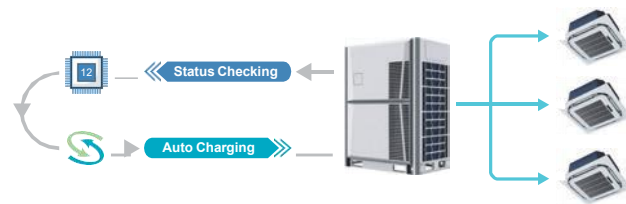

🏠 Maximum 96HP



Max.3 outdoor units can be freely combined to become a larger unit. the maximum capacity of single system is 96HP.

*:when 4 outdoor units are combined, the single unit capacity can not exceed 24HP.

1 High Efficiency

2 Benefits For Users

3 Benefits For Installers

Advantages

Provide You With Fresh Air

1

High Efficiency

Low carbon life advocate

ZERO always focus on low-carbon energy-saving products development, and spare no effort for technological research and development, to become a practitioner and advocate of low-carbon technology!

Core Technologies Make High Efficiency

Brushless DC Motor

- High efficiency
- Low noise

180° Sine Wave Control

- High precision rotor speed control

Stepless Control

- On-demand output, high efficiency and energy saving

CCT Inner-grooved Tube

- Excellent heat-exchanging efficiency

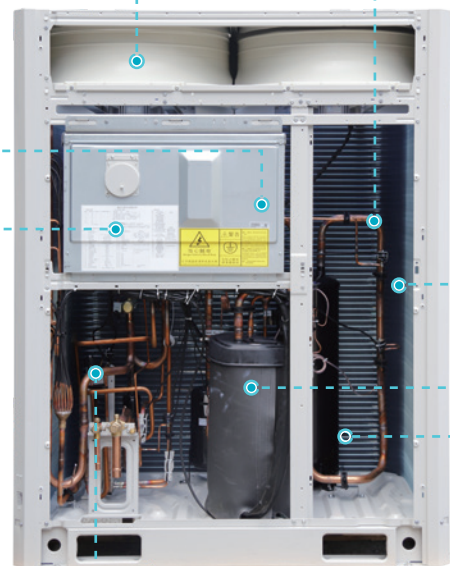

2-in-1 Refrigerant Flow Path

- Increase the liquid refrigerant volume proportion

Cross Flow Fins

- Reduce wind resistance and improve heat exchange efficiency

DC Inverter Compressors

- High pressure type
- Asymmetric scroll design
- Neodymium permanent magnet rotor
- Magnet rotor

G Type Condenser

- Enlarge the heat exchange area, and the heat exchange effect is better (Available for 22/26/28/30/32HP)

High Efficiency DC Inverter Compressor

- From Hitachi, famous inverter compressor manufacturer.
- R410a environmentally balanced refrigerant.
- Small torque fluctuation, low vibration and quiet operation.
- High efficiency due to its internal structure design.
- Internal oil circulation structure.
- High reliability.
- Wide rotation speed range.
- Neodymium permanent magnet rotor, has powerful magnetic force, large torque and high efficiency.
- Concentrated winding, improving low frequency efficiency.
- High pressure chamber
- Has small suction superheat and high refrigerant volume efficiency

Oil balance design, pump extra oil to other compressor.

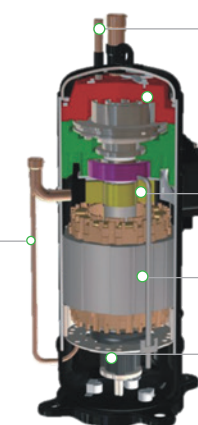

Vapor injection pipe, better performance in low temperature.

High strength bearing, high rigidity shell.

Wide frequency range.

Build in oil pump, active oil supply when compressor is running.

• Has large refrigerant discharge buffer volume, low vibration and noise

Powerful magnetic force, large force moment and high efficiency.



Ferrite magnet



Neodymium permanent magnet

Magnetic efficiency is 12% higher than distributed winding

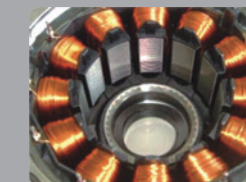

Concentrated winding

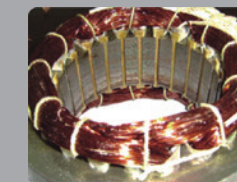

Distributed winding

High Efficiency DC Motor

High efficiency DC fan motor is from well-known brand.

Low noise and high efficiency because of high-density wire winding engineering.

Brushless with built-in sensor.

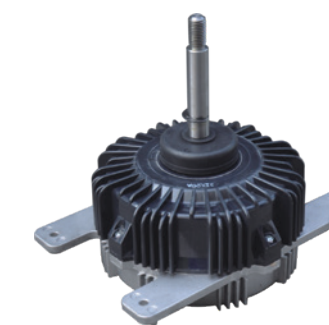

DC fan motor



Stepless Control

DC fan motor can be stepless controlled by outdoor PCB according to system's operating pressure. And it is able to reduce the energy consumption and maintain the system in the best performance.

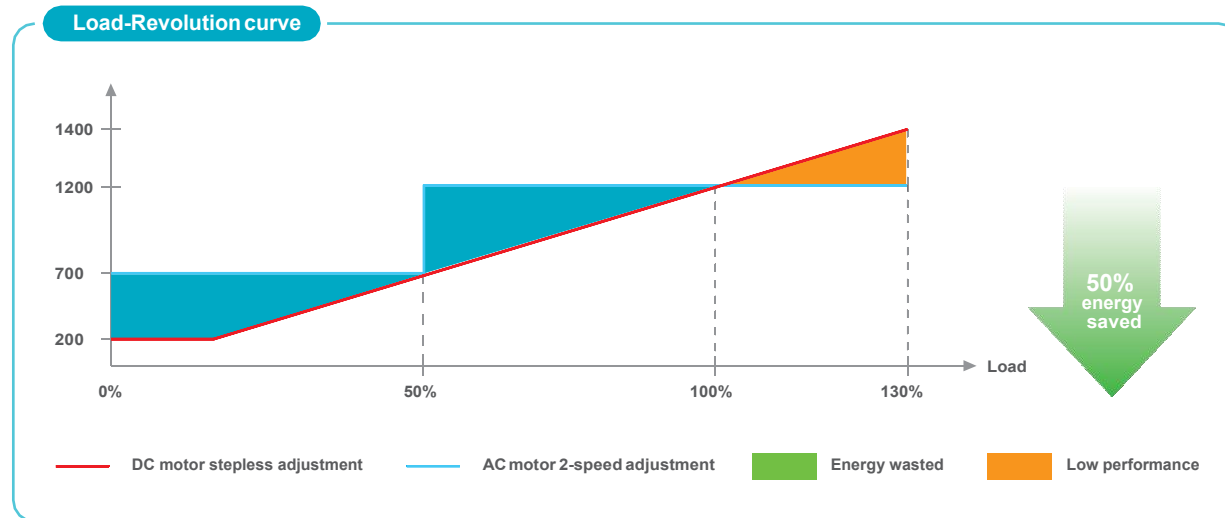

180° Sine Waveform Control

The perfect combination of 180° Sine waveform rotor frequency drive control technology and excellent IPM inverters, reduces the reactive loss of motor-driven, increases motor efficiency by 12%.

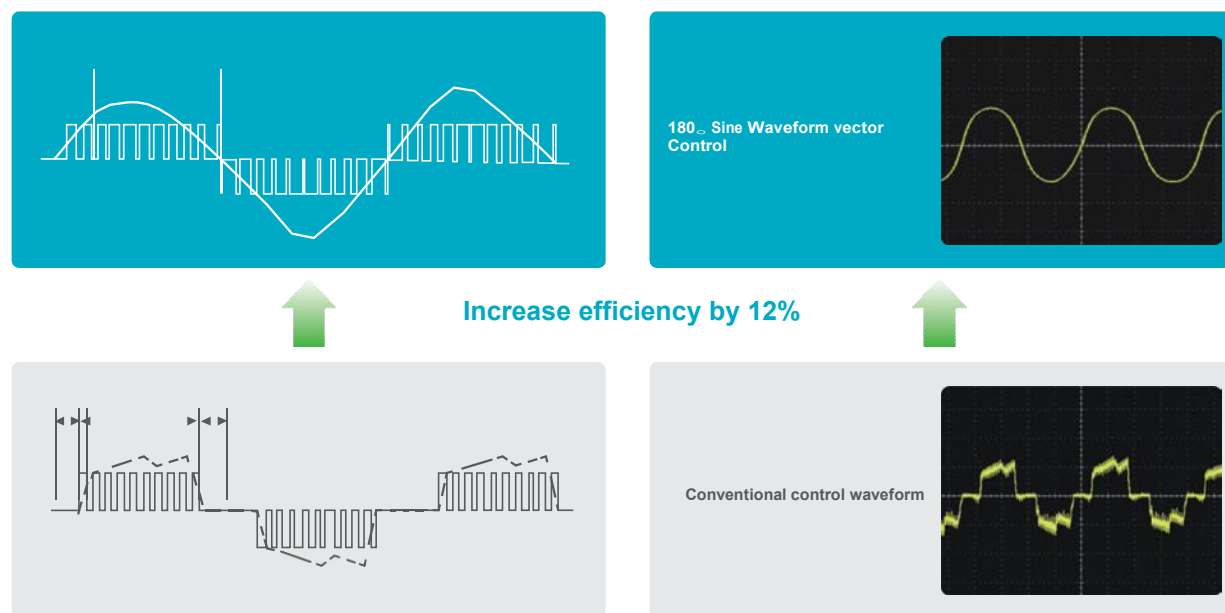

CCT Inner-grooved Tube

CCT (Continuous Cooling Transformation) inner-grooved copper tube has high thermometric conductivity. This inner-grooved fins break the refrigerant flow boundary layer to enhance refrigerant disturbance to increase heat-exchanging efficiency.

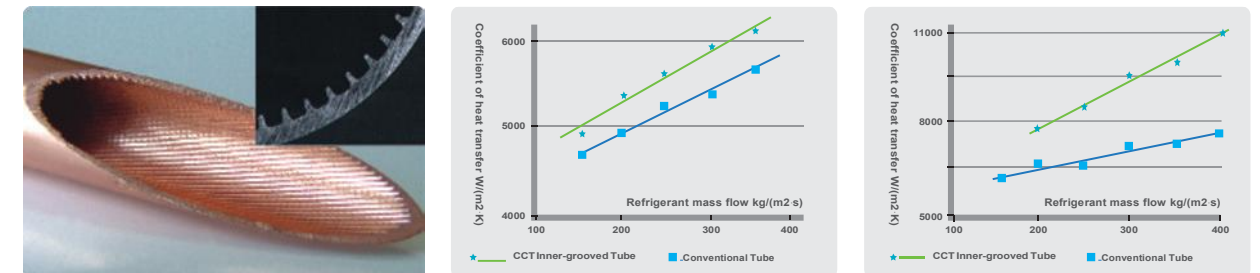

2-in-1 Refrigerant Flow Path Design

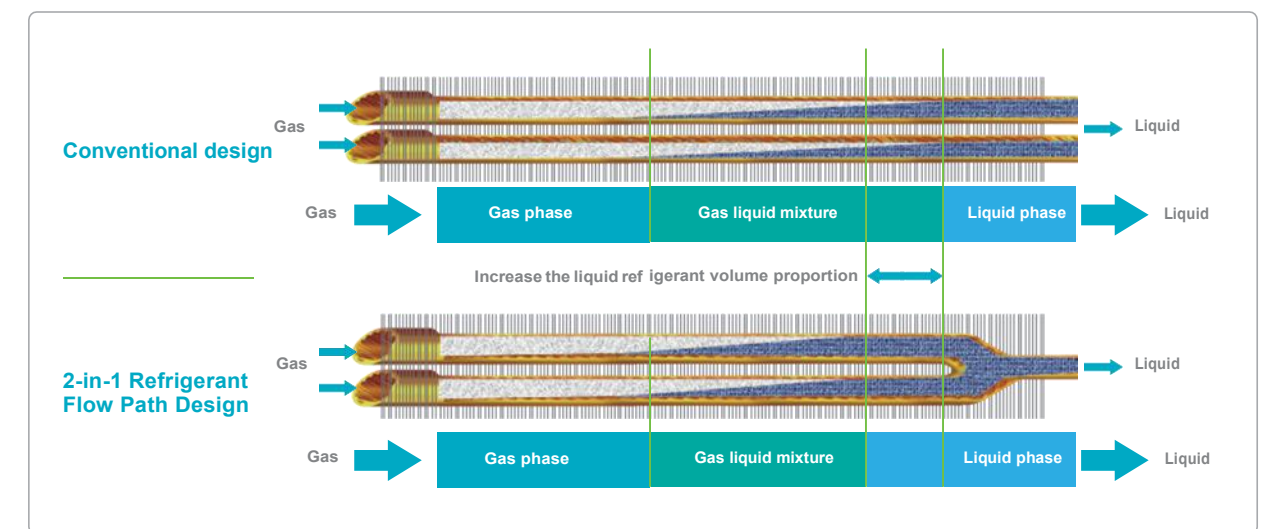
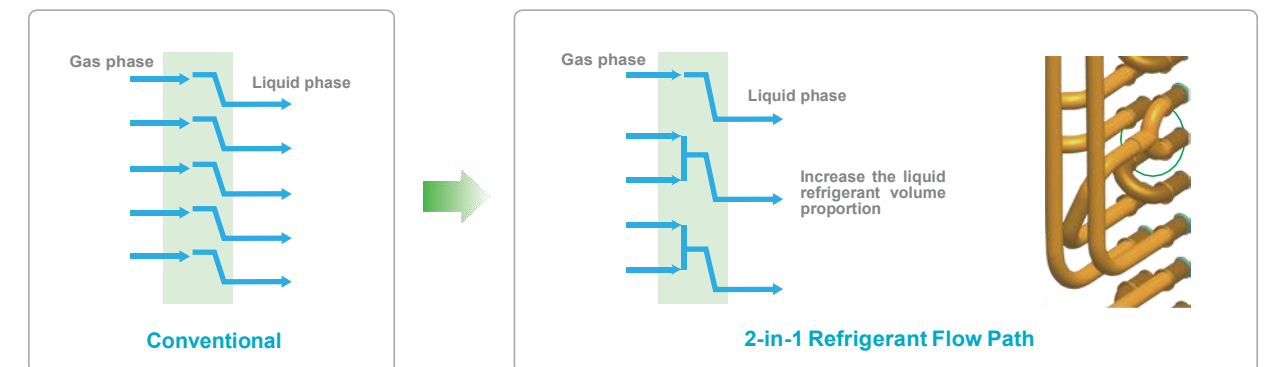

Supercooling Flow Path Design

Supercooling flow path design, separates the refrigerant inlet and outlet, increase the supercooling degree, reduce the effect of high temperature inlet gas refrigerant to low temperature outlet liquid refrigerant, therefore, the system efficiency will be greatly increased.

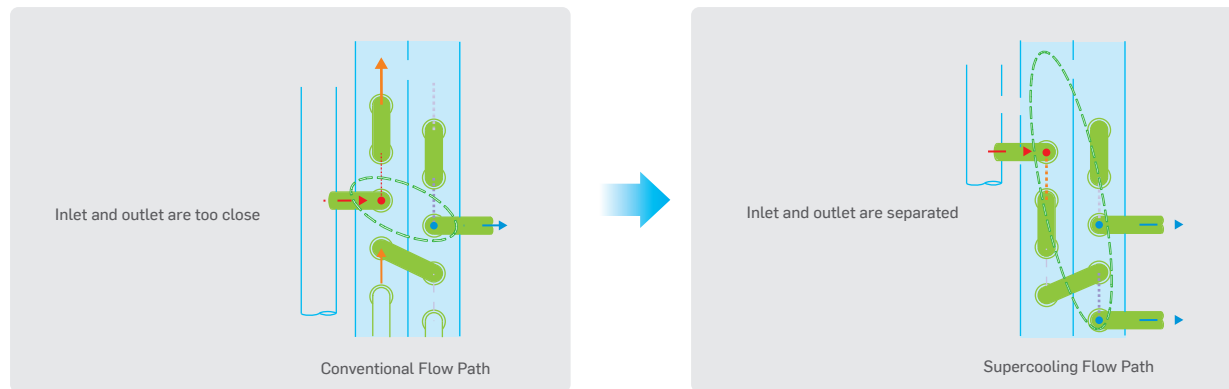

Cross Flow Fins

- Has low air resistance and great heat transfer coefficient.
- Frosting improved, frost on the heat-exchanger will be well-distributed, easy for defrosting.

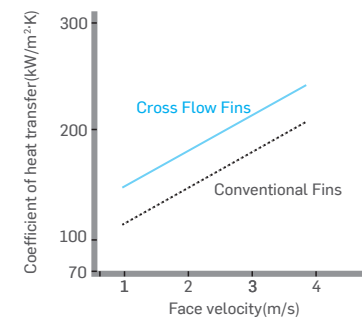
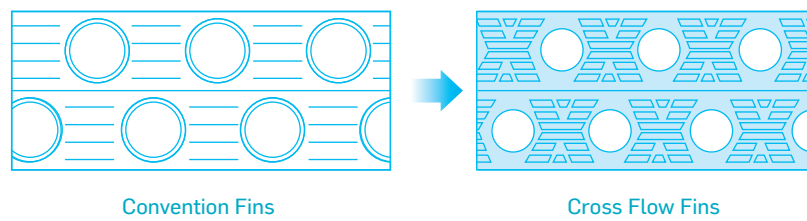

Low Resistance Internal Piping

- Thanks to the optimization pipeline design, 5% pressure drop are reduced.
- EER and COP increase, because of evaporating temperature increase and compressor work decrease.

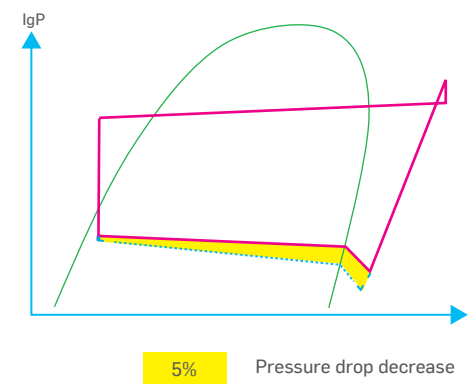
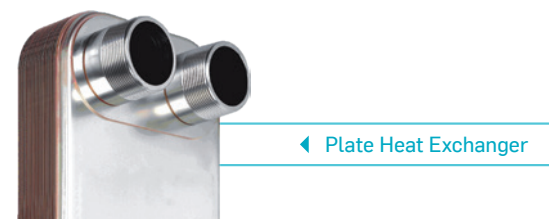

Plate Heat Exchanger

- Provides an additional sub cooling.
- Improved heat exchanger+Plate Heat Exchanger+Optimized control logic.
- Heating performance highly increased.



Benefits For Users

2

Livable environment provider

ZERO focuses on starting point of CAC system: provide a friendly, comfortable and pleasant living environment as always. DC inverter VRF system's comfort technologies include quick cooling and heating, precise temperature control, low noise, use environmental balanced refrigerant and so on, we strive to provide livable environment for users.....



Outstanding Comfort Ability

- ZERO VRF system have excellent cooling&heating performance, thanks to the high efficiency DC fan motor, DC compressor and optimized refrigerant flow control logic.
- Precisely room temperature control by adopting 2000 pulse EXV. Indoor temperature fluctuation can be maintain within 0.5°C, offers outstanding comfort ability.

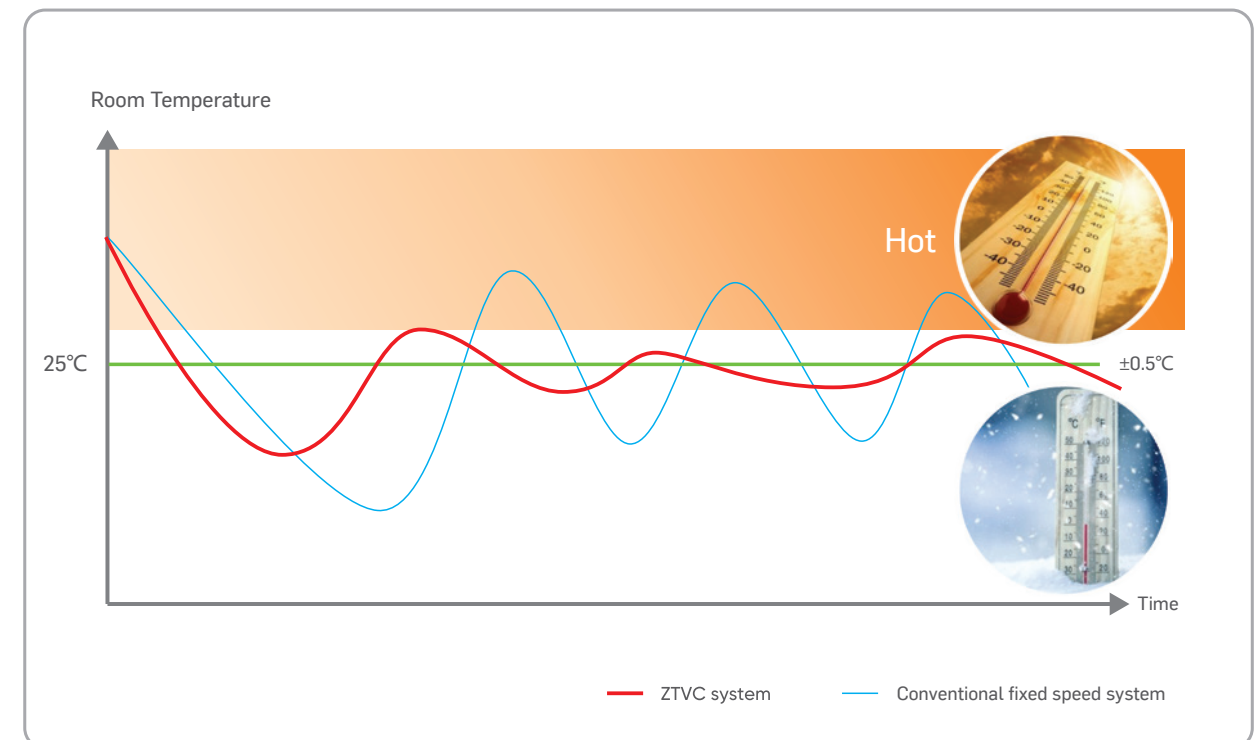



Wide Operation Range

- Due to EVI technology, ZTVC's heating performance increased by 35% compare to conventional VRF system.
- Due to EVI technology, ZTVC still has 85% of rated capacity even in -15°C.



7 Improvements To Reduce Noise

- Maximum 10dB(A) of operating sound decrease.

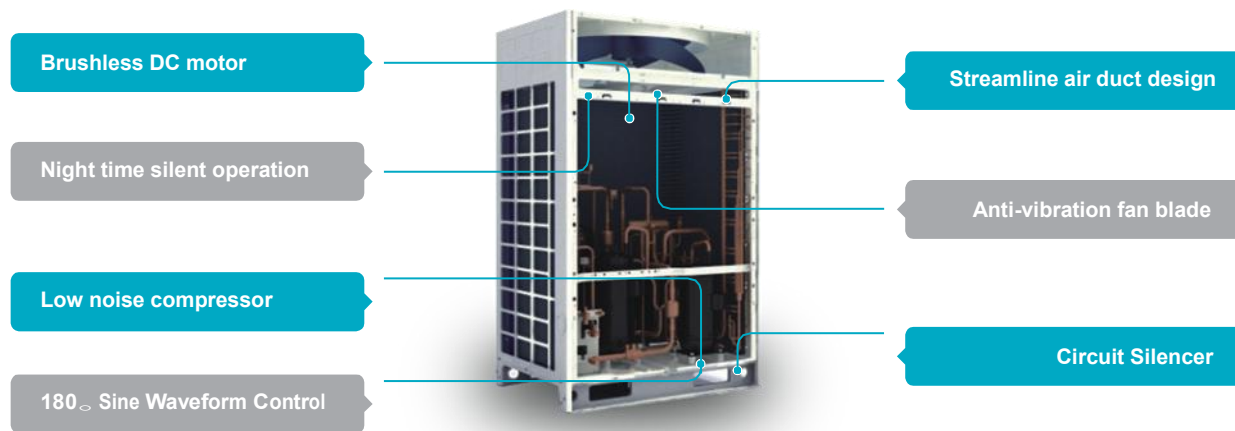

Low Noise Fan Blade

- Anti-vibration forward fan blade.
- Special design to reduce the air vibration and disturbance

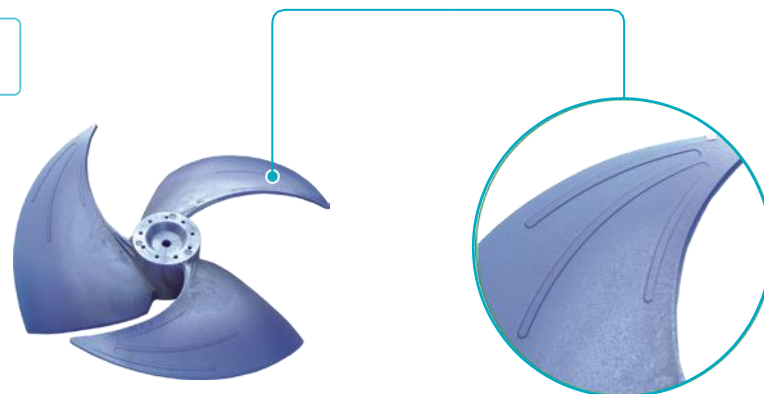

Silent Mode, Night Time Noise Control

- Compressor and fan motor rotating speed can be reduced to lower the noise at night.
- Maximum 10dB(A) decrease.

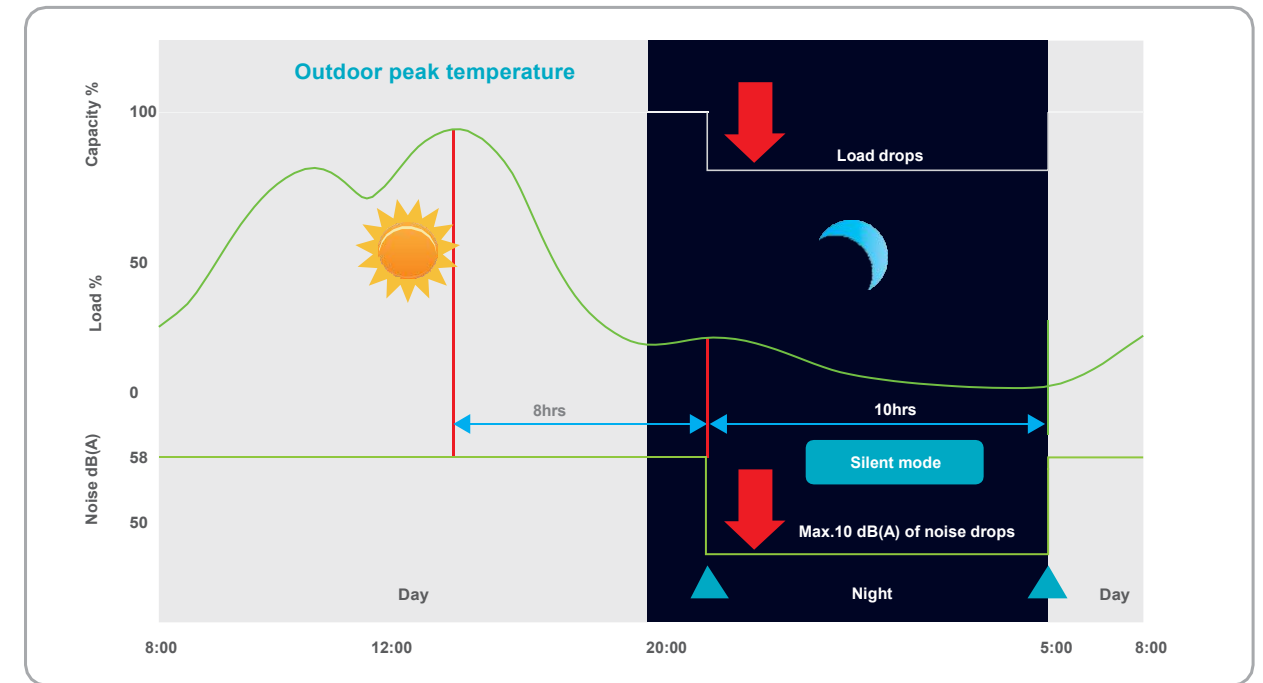

Snow-proof Function

- In the cold weather, outdoor fan will start to run for a while at intervals, for preventing the snow to accumulate on fan blade. Because accumulated snow will freeze and block fan blade rotating, even worse it will damage the motor.

- It only start when temperature is lower than 0°C.



The PHE Economizer

- PHE Economizer technology provide an additional sub cooling.
- Improved heat exchanger+PHE economizer+Optimized control logic.
- Heating performance highly increased.



◀ PHE Economizer

The PHE economizer need customization.



3-stage Back Up Function

Module back up function.

When some modules are failure, the others can keep running by simply settings.

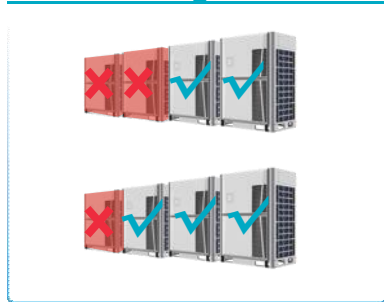

Compressor back up function

When one compressor is failure, the other one can keep running by simply settings.



Fan motor back up function.

When one fan motor is failure, the other one can keep running by simply settings.



All Outdoor Units Cycle Operation

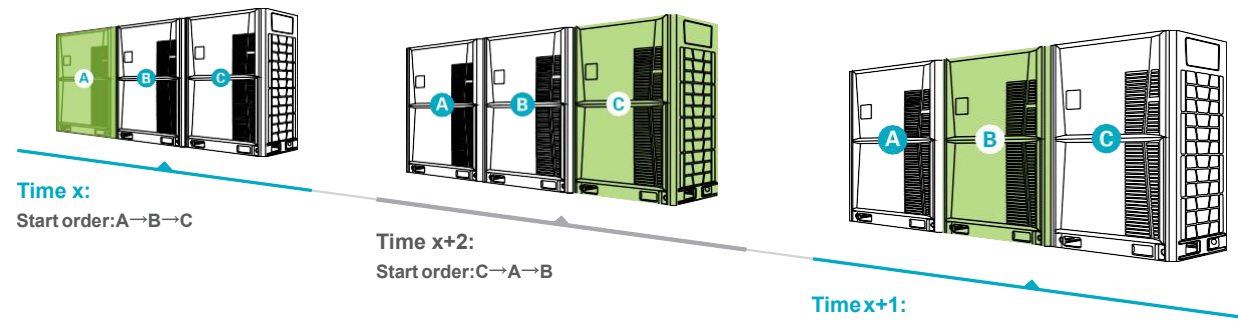

- In one combination system, any outdoor unit can run as master unit.
- Balance the lifespan among outdoor units in one system.



Intelligent Defrosting Program

Program starts only when unit needs to. Whereas conventional unit's defrosting timing & duration is fixed, causing fluctuations in temperature and personal comfort.

Defrost Curve

- Conventional unit's defrosting timing & duration is fixed
- Intelligent defrosting program starts according to heat exchanging efficiency & capacity change due to the frost. Less temperature fluctuations, people feel more comfortable

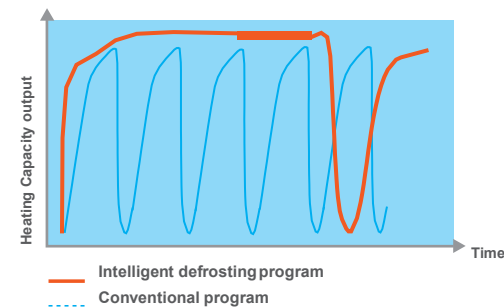

Remote ON/OFF Control Function

- Indoor units standard build in with ON/OFF control port.
- It can be used for hotel card control and also can be used for long distance remote ON/OFF control. And no need additional hotel VRF indoor unit control module.
- When contactor is open (card pulled out), indoor unit will be off can not be controlled, current running parameters will be saved in indoor PCB.
- When contactor is close (card insert), indoor unit will recover previous running state.

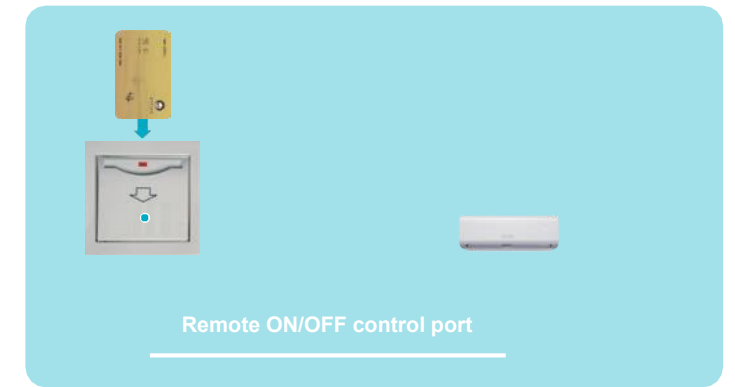

Emergency Stop Operation Function

Outdoor unit have a fire alarm linkage signal control function. When emergency situation can stop the whole AC system.



Environment Friendly

Refrigerant R410A(HFC), low carbon footprint, no harm to Ozone.

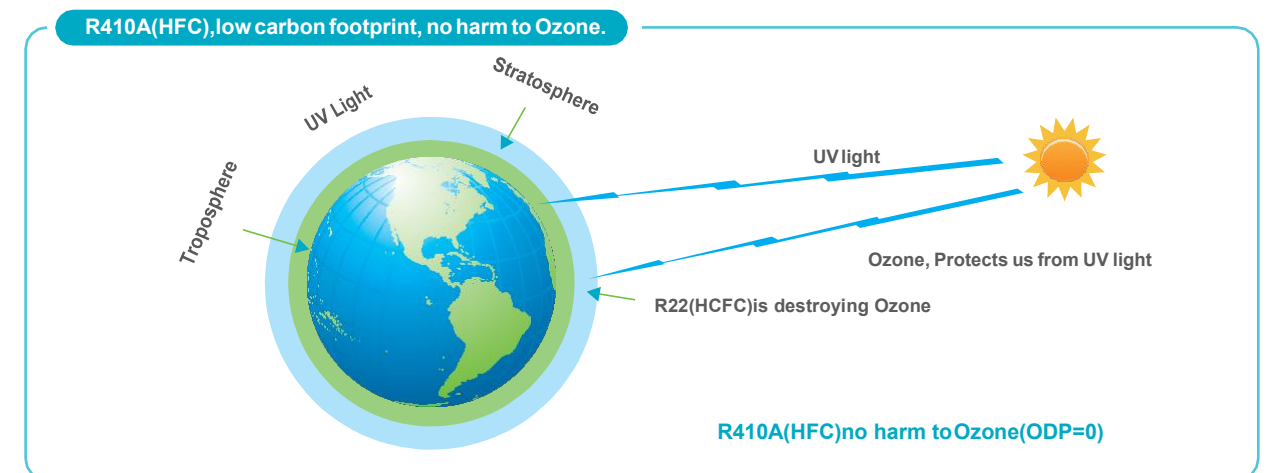



3 Benefits For Installers

Optimization for designer and installer

ZTVC DC inverter VRF system is designed with flexible modular combination concept, we keep optimizing the module size, reduce equipment on space occupied to meet the demand of designer and installer. Some unique technologies are used for our installers to reduce their working load, installation is becoming easier and easier!

Adjustable Outdoor Fan Static Pressure



- Thanks to DC fan motor, the external static pressure of outdoor fan is adjustable.
- Outdoor units can be installed in the service floor or facility room.
- Maximum ESP 85Pa.

Touch Screen Wired Controller



- Air filter cleaning reminding function.
- Touch screen with black background and white light
- Ultra thin body and stylish design meet high-end environments.
- On/off, temperature setting, fan speed setting, mode setting, timer and check function.

Addressing Methods



- 2 addressing methods:
 - Automatically addressing: system will distribute address to indoor unit automatically.
 - Manually setting by wireless remote controller.
- Addressing method can be selected easily by adjusting the switch on outdoor PCB.

Automatic Addressing

- Automatic addressing will reduce artificial faults by 35% and 5% manual works.
- 54% system failure were caused by communication faults.
- 65% communication faults were caused by address problems.
- Most of the address problems were: address setting forgotten, wrong settings, address repeat.

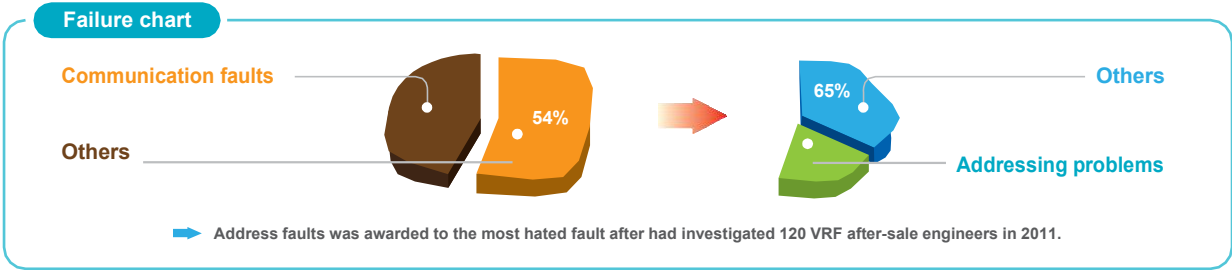

New Wired Controller

- Bidirectional communication. Indoor unit's operating parameters (error code, temperature, address) can be inquired and displayed on the controller.
 - Compact design.
 - Timer function.
-

Easy
Safe
Convenient

User can check the error code and inquiry unit status very easy, safe and convenient.

LED Display On The PCB

- LED display on the PCB, it can show system's operation status and error codes.
 - Record error code list at main PCB chip, easy for service people to check.
-

Service Window

Thanks to the service window, checking outdoor unit's status and setting is now easy, no need to remove the electric control box cover.

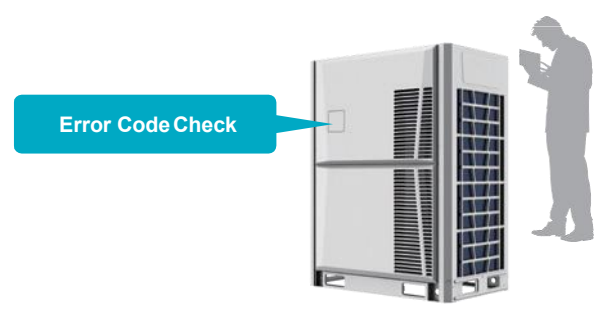

Mode Restriction

- 6 kinds of mode restriction
- Auto priority (Default Setting)
- Cooling (or heating) priority mode.
- Cooling only (or heating only) mode.
- VIP unit priority + AUTO priority mode

• Mode restriction function can be selected on the outdoor PCB.

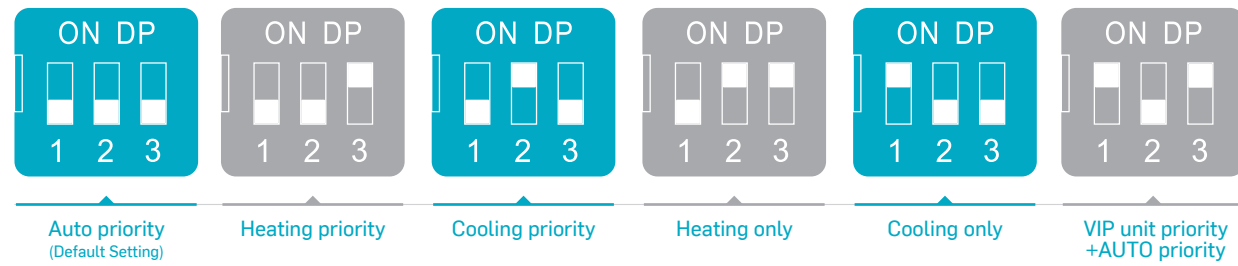

5-Stage Oil Control

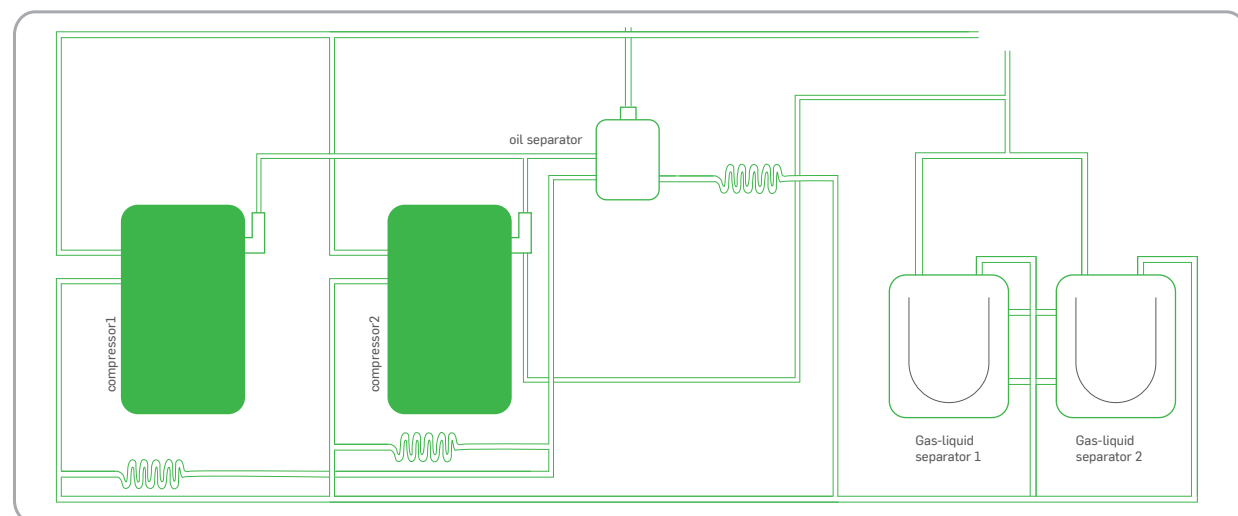
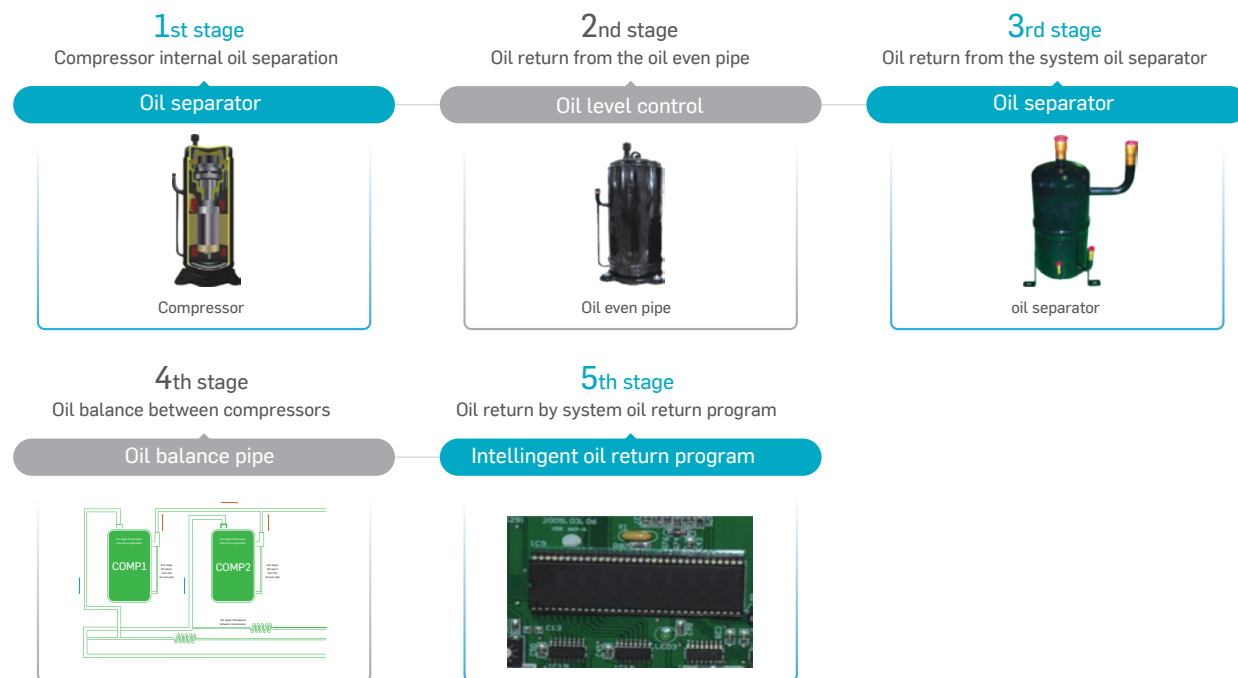

Humanized Internal Structure



- All key components are designed to close to outside, it is convenient for repair and replacement.
- Thanks to the new balance technology, gas balance pipe does no longer exist, brazing points and leaking risk are decreased.

3-Phase Power Protector (Optional)

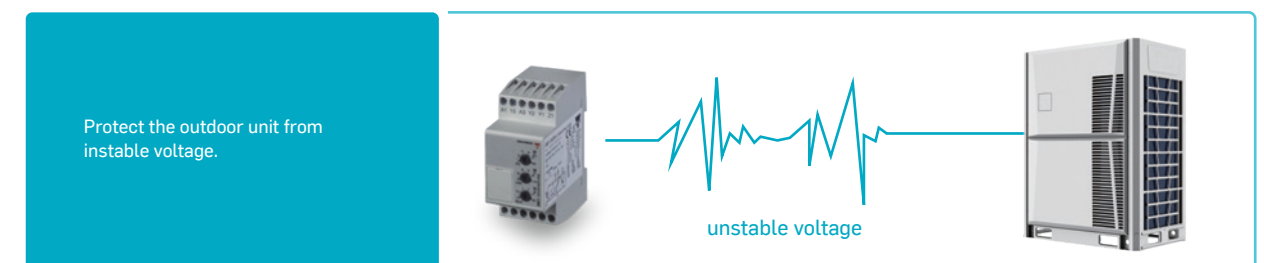

Easy Installation

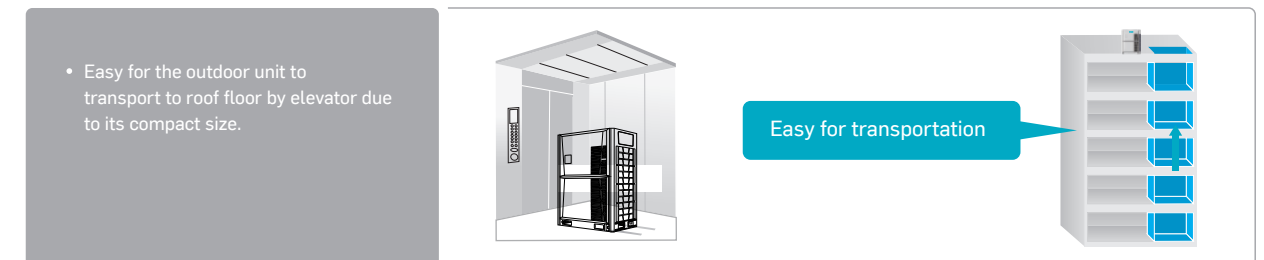

360° Pipe Connection

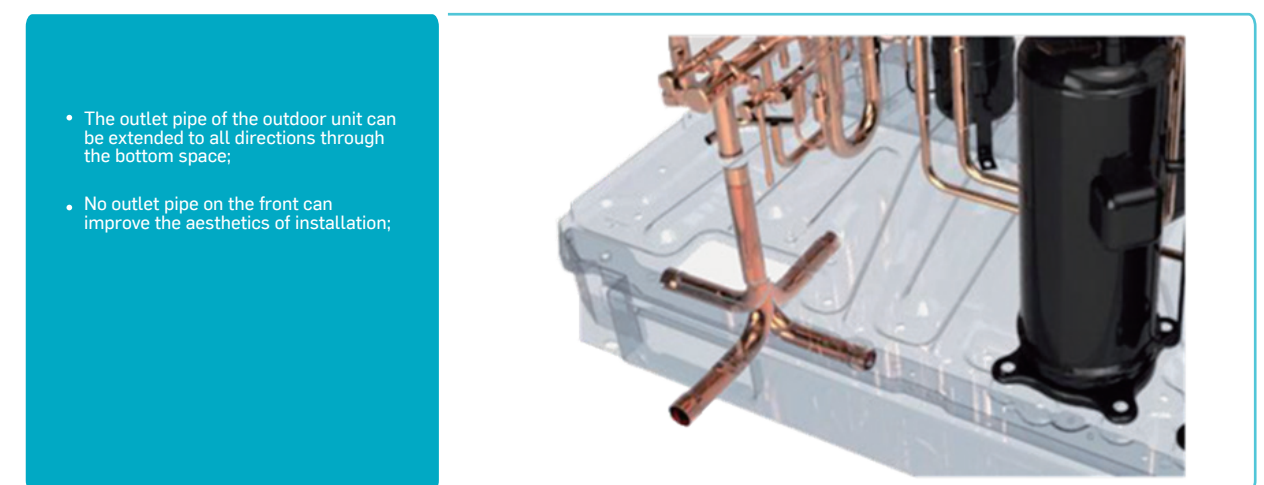

Model Name			ZTVC-CHT252DXP	ZTVC-CHT280DXP	ZTVC-CHT335DXP	ZTVC-CHT400DXP	ZTVC-CHT450DXP	
Power Supply			380-415V/3N/50&60Hz	380-415V/3N/50&60Hz	380-415V/3N/50&60Hz	380-415V/3N/50&60Hz	380-415V/3N/50&60Hz	
Performance Data								
Cooling	Capacity	HP	8HP	10HP	12HP	14HP	16HP	
		kW	25.2	28.0	33.5	40.0	45.0	
		Btu/h	86000	95500	114000	136500	153500	
	Rated current	RT	7.2	8.0	9.5	11.4	12.8	
		A	9.04	11.30	14.51	18.10	21.60	
		kW	5.31	6.22	8.35	9.76	11.63	
		W/W	4.75	4.50	4.01	4.10	3.87	
Heating	Capacity	kW	27.4	31.5	37.5	45.0	50.0	
		Btu/h	93500	107500	128000	153500	170600	
		RT	7.8	9.0	10.7	12.8	14.2	
	Rated current	A	8.93	11.25	14.34	18.00	20.25	
		kW	4.98	5.86	7.35	9.34	10.87	
COP	W/W	5.50	5.38	5.10	4.82	4.60		
Max. input consumption		kW	13.4	14.3	14.8	18.3	18.8	
Max. Current		A	23.1	24.7	25.5	30.8	31.7	
Capacity adjustment range			50%~130%					
Compressor Data								
Compressor	Quantity		1					
	Type		Scroll Compressor					
	Brand		HITACHI					
Physical Data								
Refrigerant	Type		R410a					
	Volume	Kg	9	11	14			
	Throttle type		EXV					
Dimension (WxHxD)	Net	mm	990x1740x840			1340x1740x840		
	Packing	mm	1060x1900x910			1410x1900x910		
Weight	Net	Kg	228	230	275			
	Gross	Kg	240	242	293			
Outdoor sound level		dB(A)	58	60	60	61		
Max. operating range		Mpa	4.5					
Piping Data								
Pipe size	Liquid pipe	mm	Φ12.7			Φ15.88		
	Gas pipe	mm	Φ22.2			Φ28.6		
Max. pipe length	Total pipe length	m	1000			1000		
	ODU to farthest IDU (Actual length)	m	200			200		
	ODU to farthest IDU (Equivalent length)	m	240			240		
	1st IDU distributor to farthest IDU	m	40/90			40/90		
Max. vertical length	Between ODU & IDU (ODU above IDU)	m	100			100		
	Between ODU & IDU (ODU below IDU)	m	110			110		
	Between IDUs	m	40			40		
	Between ODUs	m	0			0		
Operation Temperature Range								
Cooling	Outdoor side	℃	-5~55			-5~55		
	Indoor side	℃	16~32			16~32		
Heating	Outdoor side	℃	-25~30			-25~30		
	Indoor side	℃	16~32			16~32		

Note

- Cooling operating temperature range is from -5°C to 55°C (It can be customized down to -10°C). Heating operating temperature range from -25°C to 30°C.
- The cooling conditions: indoor side 27°C(80.6°F) DB, 19°C(60°F)WB outdoor side 35°C(95°F) DB.
- The heating conditions: indoor side 20°C(68°F) DB, 15°C(44.6°F)WB outdoor side 7°C(42.8°F) DB.
- Sound level: measured at a point 1 m in front of the unit at a height of 1.5 m. During actual operation, these values are normally somewhat higher as a result of ambient conditions.
- The above data may be changed without notice for future improvement on quality and performance.

ZTVC-CHT500DXP	ZTVC-CHT560DXP	ZTVC-CHT615DXP	ZTVC-CHT670DXP	ZTVC-CHT730DXP	ZTVC-CHT785DXP	ZTVC-CHT850DXP	ZTVC-CHT900DXP
380-415V/3N/50&60Hz	380-415V/3N/50&60Hz	380-415V/3N/50&60Hz	380-415V/3N/50&60Hz	380-415V/3N/50&60Hz	380-415V/3N/50&60Hz	380-415V/3N/50&60Hz	380-415V/3N/50&60Hz
18HP	20HP	22HP	24HP	26HP	28HP	30HP	32HP
50.0	56.0	61.5	67.0	73.0	78.5	85.0	90.0
170600	191000	209800	228600	249100	267800	290000	307100
14.2	16.0	17.5	19.1	20.8	22.3	24.2	25.6
23.29	26.10	29.06	29.09	32.59	36.13	40.36	44.73
12.22	14.66	16.62	16.71	18.18	20.03	22.37	24.79
4.09	3.82	3.70	4.01	4.02	3.92	3.80	3.63
56.0	63.0	69.0	75.0	81.5	87.5	95.0	100.0
191000	214900	235400	255900	278100	298600	324100	341200
16.0	18.0	19.7	21.3	23.2	24.9	27.0	28.4
22.61	25.70	28.40	28.65	30.28	33.38	38.52	43.90
11.89	14.16	16.80	14.72	16.78	18.50	21.35	24.33
4.71	4.45	4.11	5.10	4.86	4.73	4.45	4.11
22.0	24.4	25.0	26.2	30.1	30.7	35.8	37.7
37.4	41.1	42.1	43.2	50.8	51.8	60.4	63.6
50%~130%							
1				2			
Scroll Compressor				Scroll Compressor			
HITACHI				HITACHI			
R410a							
15	16	20	23				
EXV							
1340x1740x840				1990x1740x840			
1410x1900x910				2060x1900x910			
285	290	297	388	433	480		
303	308	315	406	452	498		
62	63	62	63	64			
4.5							
Φ15.88				Φ22.2			
Φ28.6				Φ35.0			
1000				1000			
200				200			
240				240			
40/90				40/90			
100				100			
110				110			
40				40			
0				0			
-5~55				-5~55			
16~32				16~32			
-25~30				-25~30			
16~32				16~32			

Model Name			ZTVC-CHT252DXPZ	ZTVC-CHT280DXPZ	ZTVC-CHT335DXPZ	ZTVC-CHT400DXPZ	ZTVC-CHT450DXPZ	
Power Supply			380-415V/3N/50Hz	380-415V/3N/50Hz	380-415V/3N/50Hz	380-415V/3N/50Hz	380-415V/3N/50Hz	
Performance Data								
Cooling	Capacity	HP	8HP	10HP	12HP	14HP	16HP	
		kW	25.2	28.0	33.5	40.0	45.0	
		Btu/h	86000	95500	114000	136500	153500	
	Rated current	RT	7.2	8.0	9.5	11.4	12.8	
		A	10.20	11.80	15.50	18.20	21.60	
		kW	5.50	7.00	9.20	10.80	12.80	
		W/W	4.64	4.07	3.64	3.70	3.52	
Heating	Capacity	kW	27.0	31.5	37.5	45.0	50.0	
		Btu/h	92100	107500	128000	153500	170600	
		RT	7.7	9.0	10.7	12.8	14.2	
	Rated current	A	10.00	11.60	15.40	18.00	21.00	
		kW	5.75	6.90	9.10	10.60	12.50	
COP	W/W	4.70	4.57	4.12	4.25	4.00		
Max. input consumption		kW	13.96	13.96	13.96	17.83	18.80	
Max. Current		A	24.0	24.0	24.0	29.0	31.7	
Capacity adjustment range			50%~130%					
Compressor Data								
Compressor	Quantity		1					
	Type		Rotary Compressor					
	Brand		Mitsubishi					
Physical Data								
Refrigerant	Type		R410a					
	Volume	Kg	9	11	14			
	Throttle type		EXV					
Dimension (WxHxD)	Net	mm	990x1740x840			1340x1740x840		
	Packing	mm	1060x1900x910			1410x1900x910		
Weight	Net	Kg	205	210	250	250		
	Gross	Kg	217	222	268	268		
Outdoor sound level		dB(A)	58	58	60	60		
Max. operating range		Mpa	4.5					
Piping Data								
Pipe size	Liquid pipe	mm	Φ12.7			Φ15.88		
	Gas pipe	mm	Φ22.2			Φ28.6		
Max. pipe length	Total pipe length	m	1000			1000		
	ODU to farthest IDU (Actual length)	m	200			200		
	ODU to farthest IDU (Equivalent length)	m	240			240		
	1st IDU distributor to farthest IDU	m	40/90			40/90		
Max. vertical length	Between ODU & IDU (ODU above IDU)	m	100			100		
	Between ODU & IDU (ODU below IDU)	m	110			110		
	Between IDUs	m	40			40		
	Between ODUs	m	0			0		
Operation Temperature Range								
Cooling	Outdoor side	℃	-5~55			-5~55		
	Indoor side	℃	16~32			16~32		
Heating	Outdoor side	℃	-15~30			-15~30		
	Indoor side	℃	16~32			16~32		

Note

- Cooling operating temperature range is from -5°C to 55°C (It can be customized down to -10°C). Heating operating temperature range is from -15°C to 30°C.
- The cooling conditions: indoor side 27°C(80.6°F) DB, 19°C(60°F)WB outdoor side 35°C(95°F) DB.
- The heating conditions: indoor side 20°C(68°F) DB, 15°C(44.6°F)WB outdoor side 7°C(42.8°F)DB.
- Sound level: measured at a point 1 m in front of the unit at a height of 1.5 m. During actual operation, these values are normally somewhat higher as a result of ambient conditions.
- The above data may be changed without notice for future improvement on quality and performance.

ZTVC-CHT500DXPZ	ZTVC-CHT560DXPZ	ZTVC-CHT615DXPZ	ZTVC-CHT670DXPZ	ZTVC-CHT730DXPZ	ZTVC-CHT800DXPZ	ZTVC-CHT850DXPZ
380-415V/3N/50Hz	380-415V/3N/50Hz	380-415V/3N/50Hz	380-415V/3N/50Hz	380-415V/3N/50Hz	380-415V/3N/50Hz	380-415V/3N/50Hz
Performance Data						
18HP	20HP	22HP	24HP	26HP	28HP	30HP
50.0	56.0	61.5	67.0	73.0	80.0	85.0
170600	191000	209800	228600	249000	272900	290000
14.2	16.0	17.5	19.1	20.9	22.7	24.2
24.80	29.60	31.50	36.70	34.60	36.90	46.70
14.70	17.60	18.70	21.74	20.54	25.50	27.71
3.40	3.18	3.29	3.08	3.55	3.14	3.07
56.0	63.0	69.0	75.0	81.5	88.0	95.0
191000	214900	235400	255800	278100	300300	324100
16.0	18.0	19.7	21.4	23.3	25.1	27.0
24.10	29.10	30.80	30.30	35.40	37.70	46.50
14.30	17.20	18.20	17.94	20.96	24.10	27.60
3.92	3.66	3.79	4.18	3.89	3.65	3.44
22.0	24.4	25.0	27.6	35.3	35.3	37.6
37.4	41.1	43.1	45.4	59.6	59.6	63.4
Capacity adjustment range						
50%~130%						
Compressor Data						
Quantity						
2						
Type						
Rotary Compressor						
Brand						
Mitsubishi						
Physical Data						
Type						
R410a						
15	16	20	23			
Throttle type						
EXV						
1340x1740x840			1990x1740x840			
1410x1900x910			2060x1900x910			
300	309	352	412	452		
310	319	370	430	470		
62	63	65	66			
Max. operating range						
4.5						
Piping Data						
Pipe size						
Liquid pipe						
Φ15.88			Φ22.2			
Gas pipe						
Φ28.6			Φ35.0			
Total pipe length						
1000			1000			
ODU to farthest IDU (Actual length)						
200			200			
ODU to farthest IDU (Equivalent length)						
240			240			
1st IDU distributor to farthest IDU						
40/90			40/90			
Between ODU & IDU (ODU above IDU)						
100			100			
Between ODU & IDU (ODU below IDU)						
110			110			
Between IDUs						
40			40			
Between ODUs						
0			0			
Operation Temperature Range						
Cooling						
Outdoor side						
-5~55			-5~55			
Indoor side						
16~32			16~32			
Heating						
Outdoor side						
-15~30			-15~30			
Indoor side						
16~32			16~32			

Model Name			ZTVC-CCT252DXP	ZTVC-CCT280DXP	ZTVC-CCT335DXP	ZTVC-CCT400DXP	ZTVC-CCT450DXP
Power Supply			380-415V/3N/50&60Hz				
Performance Data							
Cooling	Capacity	HP	8HP	10HP	12HP	14HP	16HP
		kW	25.2	28.0	33.5	40.0	45.0
		Btu/h	86000	95500	114000	136500	153500
		RT	7.2	8.0	9.5	11.4	12.8
	Power input	kW	5.86	6.79	9.18	10.50	12.20
	EER	W/W	4.30	4.12	3.65	3.80	3.68
Rated. input consumption		kW	13.90	14.10	14.60	17.96	18.34
Rated. current		A	24.0	24.5	25.2	30.2	31.0
Capacity adjustment range			50%~130%				
Compressor Data							
DC Inverter compressor	Quantity		1				
	Type		DC /Twin-rotary				
	Brand		Mitsubishi				
	Frequency range	Hz	10~120				
Physical Data							
Refrigerant	Type		R410a				
	Volume	Kg	10		12.5		
Dimension (DxHxW)	Net	mm	840x1740x990			840x1740x1340	
	Packing	mm	910x1900x1060			910x1900x1410	
Weight	Net	Kg	210			260	
	Gross	Kg	220			278	
Outdoor sound level		dB(A)	58	60		61	
Maximum operating pressure		MPa	4.5				
Piping & Wiring Data							
Pipe size	Liquid pipe	mm	Φ12.7			Φ15.9	
	Gas pipe	mm	Φ22.2			Φ28.6	
Max. pipe length	Total pipe length	m	1000				
	From OU to farthest IU(Actual length)	m	200				
	From OU to farthest IU (Equivalent length)	m	240				
	From 1st indoor distributor to farthest IU	m	90				
Max. Vertical length	Between OU & IU (OU above IU)	m	100				
	Between OU & IU (OU below IU)	m	110				
	Between IUs	m	40				
	Between Ous	m	0				
Operation Temperature Range							
Cooling	Outdoor side	℃	-5~55				
	Indoor side	℃	16~32				

Note

*The above data may be changed without notice for future improvement.

ZTVC-CCT500DXP	ZTVC-CCT560DXP	ZTVC-CCT615DXP	ZTVC-CCT670DXP	ZTVC-CCT730DXP	ZTVC-CCT800DXP	ZTVC-CCT850DXP
380-415V/3N/50&60Hz						
Performance Data						
18HP	20HP	22HP	24HP	26HP	28HP	30HP
50.0	56.0	61.5	67.0	73.0	80.0	85.0
170600	191000	209800	228600	249100	273038	290000
14.2	16.0	17.5	19.1	20.8	22.8	24.2
15.10	17.60	20.36	20.81	23.10	25.97	29.11
3.31	3.18	3.02	3.22	3.16	3.08	2.92
18.74	25.90	27.80	29.50	32.00	32.00	36.50
32.0	46.6	47.5	51.0	53.0	53.0	63.0
Capacity adjustment range						
50%~130%						
Compressor Data						
1	2					
DC /Twin-rotary						
Mitsubishi						
10~120						
Physical Data						
R410a						
12.5	16.5	18.0	20.0	25.0		
840x1740x1340			840x1740x1990			
910x1900x1410			910x1900x2060			
260	298	306	358			410
278	316	324	376			428
62	63	65	66			67
Maximum operating pressure						
4.5						
Piping & Wiring Data						
Φ15.9		Φ22.2				
Φ28.6		Φ35				
Max. pipe length						
1000						
200						
240						
90						
Max. Vertical length						
100						
110						
40						
0						
Operation Temperature Range						
-5~55						
16~32						

Model Name			ZTVC-CHT252CY	ZTVC-CHT280CY	ZTVC-CHT335CY	ZTVC-CHT400CY
Power Supply			208-230V/3N/60Hz	208-230V/3N/60Hz	208-230V/3N/60Hz	208-230V/3N/60Hz
Performance Data						
Cooling	Capacity	HP	8HP	10HP	12HP	14HP
		kW	25.2	28.0	33.5	40.0
		Btu/h	85000	93800	114000	136500
		RT	7.1	7.9	9.5	11.4
	Power input	kW	5.28	6.25	7.86	9.33
EER	W/W	4.77	4.48	4.26	4.29	
Heating	Capacity	kW	27.4	31.5	37.5	45
		Btu/h	93500	107500	128000	153500
		RT	7.8	9	10.7	12.8
	Power input	kW	5.46	6.58	8.61	9.32
EER	W/W	5.02	4.79	4.36	4.83	
Capacity adjustment range			50%-130%			
Compressor	Quantity		1			
	Type		DC /Scroll			
	Brand		Mitsubishi			
Physical Data						
Refrigerant type/volume		kg	R410A/12		R410A/16	
Dimension (DxHxW)	Net	mm	840x1740x990		840x1740x1340	
	Packing	mm	910x1900x1060		910x1900x1410	
Weight	Net	kg	220		275	
	Gross	kg	230		290	
Outdoor sound level		dB(A)	67		71	
Maximum operating pressure		MPa	4.5			
Piping Data						
Pipe size	Liquid pipe	mm	Ø12.7		Ø15.9	
	Gas pipe	mm	Ø22.2		Ø28.6	
Max. pipe length	Total pipe length	m	1000			
	From OU to farthest IU (Actual length)	m	190			
	From OU to farthest IU (Equivalent length)	m	220			
	From 1st indoor distributor to farthest IU	m	40			
Max. Vertical length	Between OU & IU (OU above IU)	m	90			
	Between OU & IU (OU below IU)	m	110			
	Between IUs	m	30			
	Between Ous	m	0			
Operation Temperature Range						
Cooling	Outdoor side	°C	-5~55			
	Indoor side	°C	17~32			
Heating	Outdoor side	°C	-15~30			
	Indoor side	°C	15~30			

Note *The above data may be changed without notice for future improvement.

ZTVC-CHT450CY			ZTVC-CHT500CY	ZTVC-CHT560CY	ZTVC-CHT615CY	
Power Supply			208-230V/3N/60Hz	208-230V/3N/60Hz	208-230V/3N/60Hz	208-230V/3N/60Hz
Performance Data						
Cooling	Capacity	HP	16HP	18HP	20HP	22HP
		kW	45.0	50.0	56.0	61.5
		Btu/h	153500	169000	191000	209800
		RT	12.8	14.1	16	17.5
	Power input	kW	11.12	12.68	15.32	17.62
EER	W/W	4.05	3.94	3.66	3.49	
Heating	Capacity	kW	50	56	63	69
		Btu/h	170600	191000	214900	235400
		RT	14.2	16	18	19.7
	Power input	kW	10.59	12.54	14.88	17.52
EER	W/W	4.72	4.47	4.23	3.94	
Capacity adjustment range			50%-130%			
Compressor	Quantity		1	2		
	Type		DC /Scroll			
	Brand		Mitsubishi			
Physical Data						
Refrigerant type/volume		kg	R410A/16	R410A/20		
Dimension (DxHxW)	Net	mm	840x1740x1340			
	Packing	mm	910x1900x1410			
Weight	Net	kg	275	325		
	Gross	kg	290	340		
Outdoor sound level		dB(A)	71	72		
Maximum operating pressure		MPa	4.5			
Piping Data						
Pipe size	Liquid pipe	mm	Ø15.9			
	Gas pipe	mm	Ø28.6			
Max. pipe length	Total pipe length	m	1000			
	From OU to farthest IU (Actual length)	m	190			
	From OU to farthest IU (Equivalent length)	m	220			
	From 1st indoor distributor to farthest IU	m	40			
Max. Vertical length	Between OU & IU (OU above IU)	m	90			
	Between OU & IU (OU below IU)	m	110			
	Between IUs	m	30			
	Between Ous	m	0			
Operation Temperature Range						
Cooling	Outdoor side	°C	-5~55			
	Indoor side	°C	17~32			
Heating	Outdoor side	°C	-15~30			
	Indoor side	°C	15~30			

Model Name			ZTVC-CCT252CYP	ZTVC-CCT280CYP	ZTVC-CCT335CYP	ZTVC-CCT400CYP
Power Supply			208-230V/3N/60Hz			
Performance Data						
Cooling	Capacity	HP	8HP	10HP	12HP	14HP
		kW	25.2	28.0	33.5	40.0
		Btu/h	86000	95500	114000	136500
		RT	7.2	8.0	9.5	11.4
	Power input	kW	5.82	6.81	9.05	10.47
	EER	W/W	4.33	4.11	3.70	3.82
Rated. input consumption		kW	13.50	14.10	14.20	16.90
Rated. current		A	40.0	42.0	45.0	50.0
Capacity adjustment range			50%~130%			
Compressor Data						
DC Inverter compressor	Quantity		1			
	Type		DC /Twin-rotary			
	Brand		Mitsubishi			
	Frequency range	rps	10-120			
Physical Data						
Refrigerant	Type		R410a			
	Volume	Kg	8		12	
Dimension (DxHxW)	Net	mm	840x1740x990		840x1740x1340	
	Packing	mm	910x1900x1060		910x1900x1410	
Weight	Net	Kg	208		260	
	Gross	Kg	218		278	
Outdoor sound level		dB(A)	58		60	
Maximum operating pressure		MPa	4.5			
Piping & Wiring Data						
Pipe size	Liquid pipe	mm	Φ12.7		Φ15.9	
	Gas pipe	mm	Φ25.4		Φ31.8	
Max. pipe length	Total pipe length	m	1000			
	From OU to farthest IU(Actual length)	m	190			
	From OU to farthest IU (Equivalent length)	m	220			
	From 1st indoor distributor to farthest IU	m	90			
Max. Vertical length	Between OU & IU (OU above IU)	m	90			
	Between OU & IU (OU below IU)	m	110			
	Between IUs	m	30			
	Between Ous	m	0			
Operation Temperature Range						
Cooling	Outdoor side	℃	-5~50			
	Indoor side	℃	16~32			

Note

*The above data may be changed without notice for future improvement.

ZTVC-CCT450CYP	ZTVC-CCT500CYP	ZTVC-CCT560CYP	ZTVC-CCT615CYP	ZTVC-CCT670CYP
208-230V/3N/60Hz				
Performance Data				
16HP	18HP	20HP	22HP	24HP
45.0	50.0	56.0	61.5	67.0
153500	170600	191000	209800	228600
12.8	14.2	16.0	17.5	19.0
12.13	14.62	17.13	19.84	22.11
3.71	3.42	3.27	3.10	3.03
17.30	24.00	26.50	27.00	27.00
53.0	70.0	78.0	80.0	80.0
Capacity adjustment range				
50%~130%				
Compressor Data				
1	2			
DC /Twin-rotary				
Mitsubishi				
10-120				
Physical Data				
R410a				
12	13	14	14	15
840x1740x1340				
910x1900x1410				
260	288	296	296	306
278	306	314	314	324
61	62	63	63	63
Maximum operating pressure				
4.5				
Piping & Wiring Data				
Φ15.9				
Φ31.8				
1000				
190				
220				
90				
90				
110				
30				
0				
Operation Temperature Range				
-5~50				
16~32				

Mini VRF

Small Capacity Full DC Inverter VRF Unit



Features

Long Refrigerant Piping

The total pipe length	100m(8-22.4kW), 120m(26-33.5kW)
The longest pipe length	Actual length 60m Equivalent length 70m
Equivalent length from first indoor distributor to last indoor unit	20m
Height difference between indoor and outdoor unit:	Outdoor unit above ≤30m Outdoor unit below ≤20m
Height difference between indoor units	8m

*Please refer to the installation manual for detailed length description.

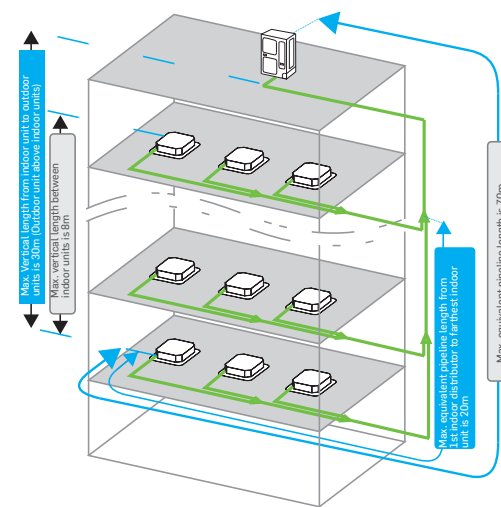

High Efficiency DC Inverter Compressor

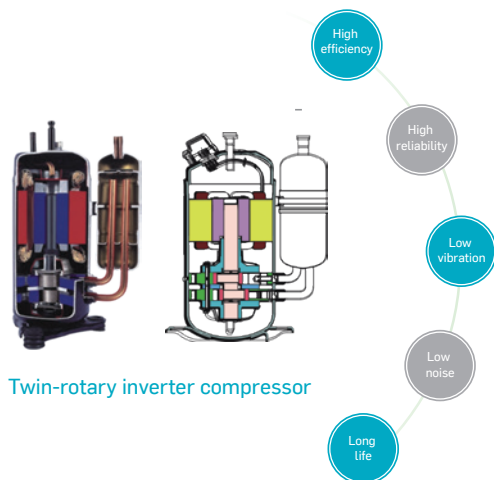

Twin-rotary DC inverter compressor

- Use high efficiency and reliability compressor
- Has very good efficiency in part load condition

High Efficiency, Low Noise

- Optimized the efficiency and noise during operation with the latest technology.

Environmental Protection

- Developed the compressor with alternative refrigerant which can protect environment.

Low Vibration

- Reduced the vibration during compressor start and operation by using 2CYL Structure, simplified the match of air-conditioning.

High Efficiency DC Motor



- ◆ High efficiency DC fan motor
- ◆ Low noise and high efficiency because of high-density wire winding engineering
- ◆ Brushless with built-in sensor

Space Saving Installation

- Multiple indoor units can be connected to 1 outdoor unit, and long piping connection is also possible.
- Compare to one-drive-one type, the outdoor unit can be installed in various places to realize the space-saving installation.

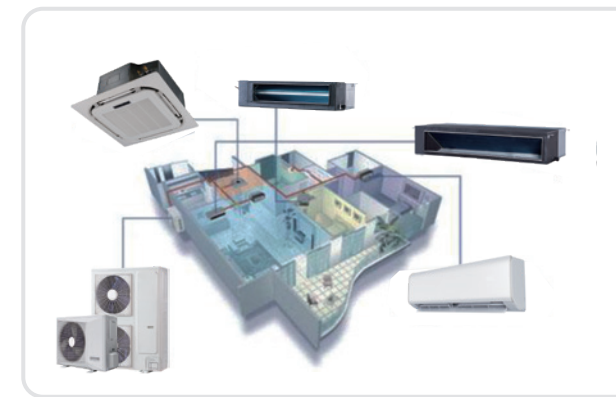

180° Sine Wave Control

The perfect combination of 180° Sine wave rotor frequency drive control technology and excellent IPM inverters, reduces the reactive loss of motor-driven, increases motor efficiency by 12%.

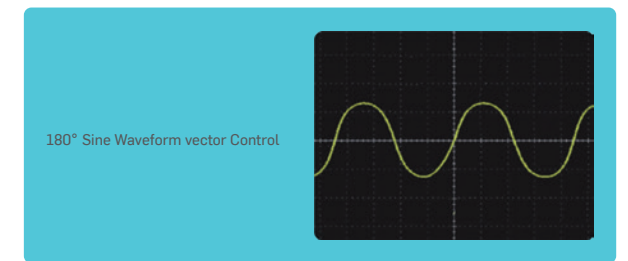
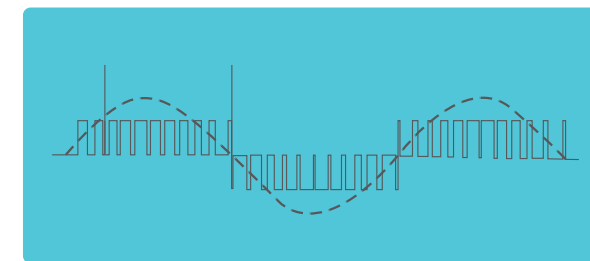

Increase efficiency by 12%

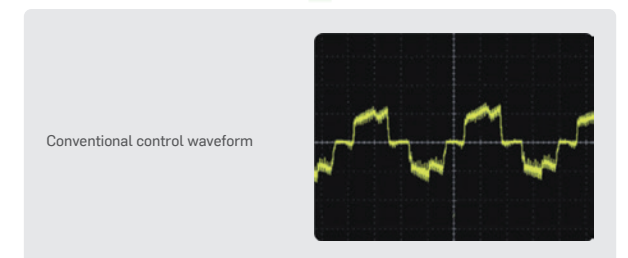
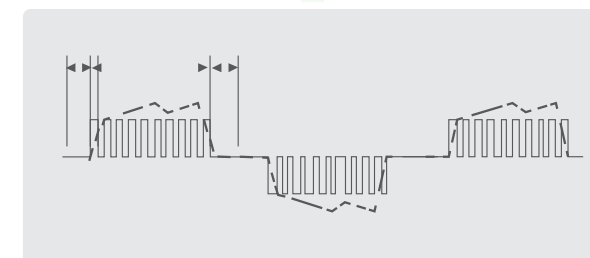

Low Noise

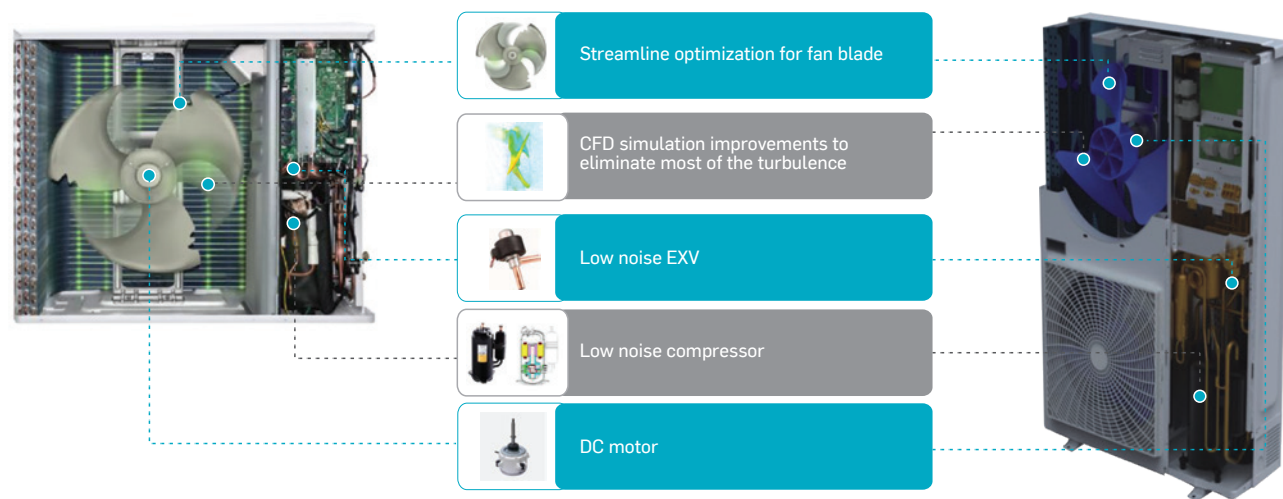

Fan Reversal Protection

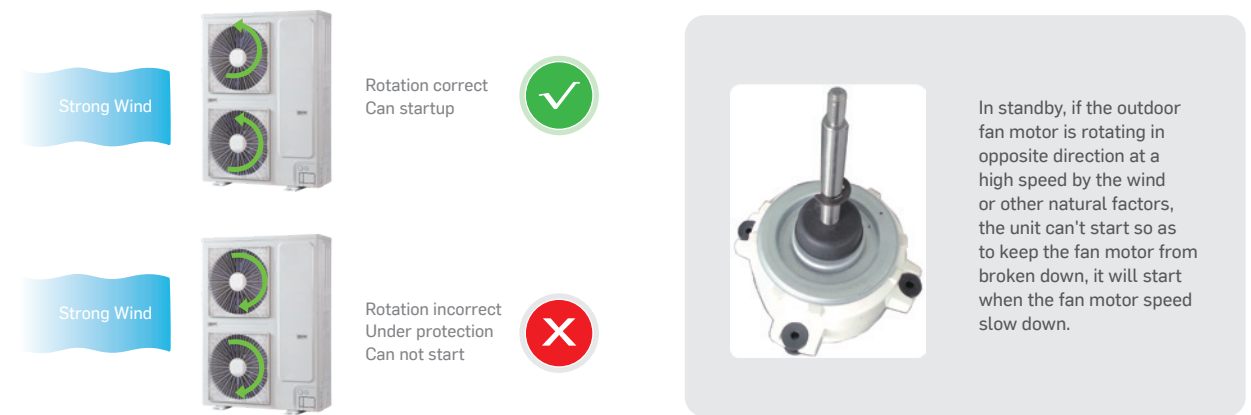

Wide Outdoor Operation Range

Max. cooling operating temperature is designed up to 55°C. Heating operating temperature is down to -20°C.

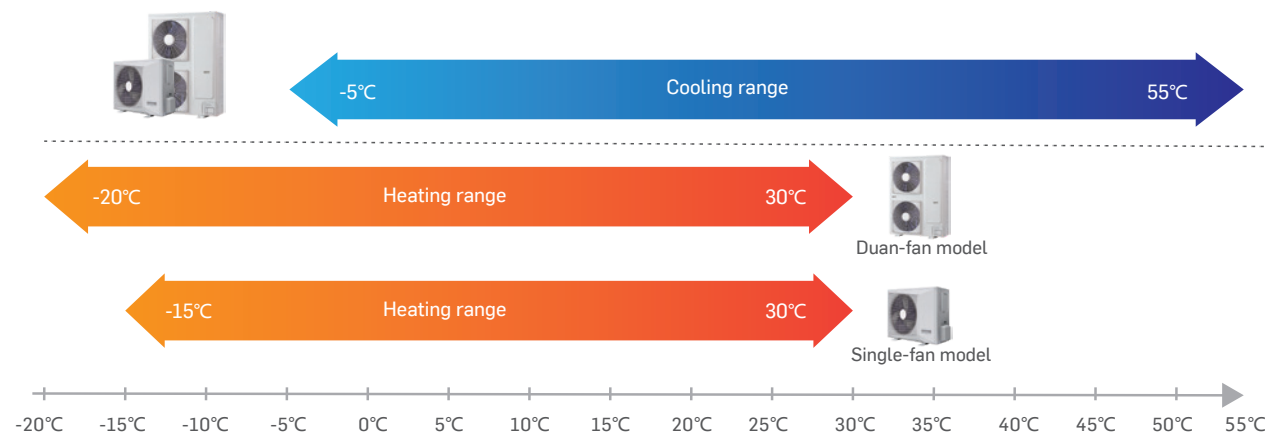

Mode Restriction

- 7 kinds of mode restriction
 - Auto priority (Default Setting)
 - Cooling priority mode
 - Heating priority mode.
 - First start mode
 - Cooling only mode
 - Heating only mode
 - VIP unit priority+AUTO priority mode
- Mode restriction function can be selected on the outdoor PCB.

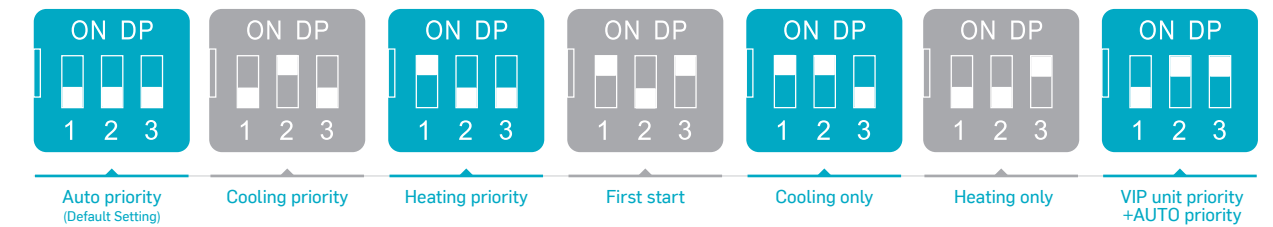

Intelligent Defrosting Program

Program starts only when unit needs to. Whereas conventional unit's defrosting timing & duration is fixed, causing fluctuations in temperature and personal comfort.

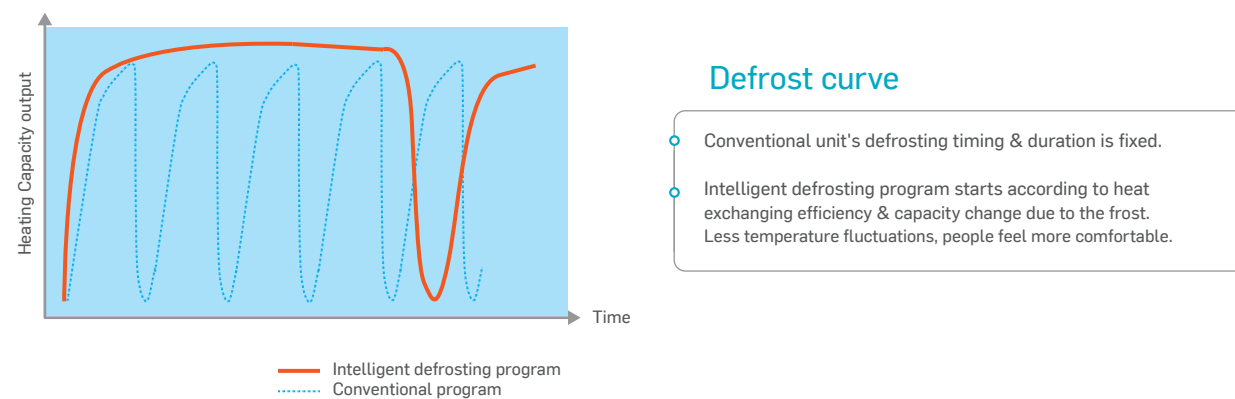

High Efficiency

Refrigerant cooling technology for PCB

- The radiation fin is made of aluminum panels fitting together seamlessly.
- This helps to cool down the IPM, it has better performance compared to air cooling for PCB.
- The outdoor unit has capability to run in max. 55°C ambient temperature.

NEW TECHNOLOGY

Automatically Addressing

- Automatically addressing: system will distribute address to indoor unit automatically.
- Automatic addressing will reduce artificial faults and manual works.

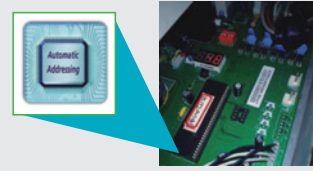

Independent Display Board

Digital display

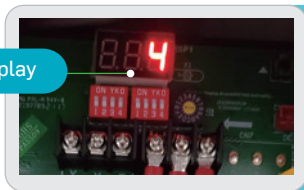

Digital display on the PCB, it can show system's operation status and error codes.

Service Window

- Service window on the right side to connect the cable and digital display to check the running data.
- One button to start the system to do the running test.

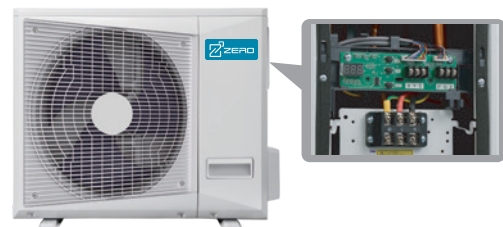

Refrigerant cooling tech. for PCB

- Good performance with enhanced refrigerant cooling solution
- Intelligent refrigerant control technology to protect PCB
- Quick action speed to make the main PCB working at suitable temperature range
- High reliability

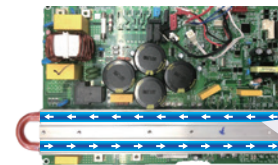

The cold refrigerant flows through the PCB and takes away the heat of the PCB through the aluminum heat exchange plate to ensure the long-term stable operation.

Dual-fan

Model name	Power type (V/N/Hz)	Cooling				Heating				Compressor Type	Qty	Motor Type	Qty	Refrigerant Type	Volume (kg)	Sound pressure Level (DB(A))	Dimension (WxHxD)		Weight		Connecting		Max. Connected indoor units quantity
		Capacity (kW)	Capacity (Btu/h)	Power input (kW)	EER	Capacity (kW)	Capacity (Btu/h)	Power input (kW)	COP								Packing (mm)	Body (mm)	Net (kg)	Gross (kg)	Gas (mm)	Liquid (mm)	
ZTVC-CHS125DX	380-415/3/50	12.5	42000	3.38	3.70	14	47000	3.26	4.29	DC/Twin-rotary	1	DC/fan motor	2	R410a	3.45	56	1010 x 1445 x 415	975 x 1335 x 400	86.6	96.4	Φ15.88		7
ZTVC-CHS140DX	380-415/3/50	14	47800	3.80	3.68	16	54000	3.97	4.03								3.8	8					
ZTVC-CHS160DX	380-415/3/50	16	54000	4.53	3.53	18	61000	4.61	3.91								3.8	9					
ZTVC-CHS180DX	380-415/3/50	18	61000	5.18	3.47	20	68000	5.02	3.98								4.2	10					
ZTVC-CHS200DX	380-415/3/50	20	68200	5.92	3.38	22	75000	5.35	4.11								5.3	11					
ZTVC-CHS224DX	380-415/3/50	22.4	76400	6.75	3.32	24	81800	5.62	4.27								5.3	13					
ZTVC-CHS260DX	380-415/3/50	26	88700	7.54	3.45	28.5	97200	6.77	4.21								6.1	15					
ZTVC-CHS280DX	380-415/3/50	28	95500	8.31	3.37	31.5	107500	8.18	3.85								8.0	16					
ZTVC-CHS335DX	380-415/3/50	33.5	114300	9.46	3.54	37.5	128000	8.99	4.17	8.0	19												

Note

1.Cooling Operation Conditions:
Indoor Air Inlet Temperature: 27°C DB / 19°C WB, T1: Outdoor Air Inlet Temperature: 35°C DB
2.Heating Operation Conditions:
Indoor Air Inlet Temperature: 20.0°C DB, Outdoor Air Inlet Temperature: 7°C DB / 6°C WB

Single-fan

Model name	ZTVC-CHS080BXP	ZTVC-CHS100BXP	ZTVC-CHS125BXP	ZTVC-CHS125DXP-D01	ZTVC-CHS140BXP	ZTVC-CHS140DXP-F01	ZTVC-CHS160BXP	ZTVC-CHS160DXP-F01
	ZTVC-CHS080BYP	ZTVC-CHS100BYP	ZTVC-CHS125BYP	ZTVC-CHS125DXP-D01	ZTVC-CHS140BXP	ZTVC-CHS140DXP-F01	ZTVC-CHS160BXP	ZTVC-CHS160DXP-F01
Power supply	220-240V/1N/50Hz 208-230V/1N/60Hz	220-240V/1N/50Hz 208-230V/1N/60Hz	220-240V/1N/50Hz 208-230V/1N/60Hz	380-415V/3N/50Hz 380-415V/3N/60Hz	220-240V/1N/50Hz 208-230V/1N/60Hz	380-415V/3N/50Hz 380-415V/3N/60Hz	220-240V/1N/50Hz 208-230V/1N/60Hz	380-415V/3N/50Hz 380-415V/3N/60Hz

Performance data										
Cooling	Capacity	kW	8	10	12.5	12.5	14	14	16	16
		Btu/h	27300	34100	42600	42600	47800	47800	54600	54600
	Power input	kW	2.60	3.00	3.20	3.20	3.75	3.75	4.75	4.75
	Rated current	A	11.8	13.6	14.5	6.0	17.0	7.0	21.8	8.8
Heating	EER	W/W	3.08	3.33	3.91	3.91	3.73	3.73	3.37	3.37
	Capacity	kW	9	11	14	14	16	16	17	17
		Btu/h	30700	37500	47800	47800	54600	54600	58000	58000
	Power input	kW	2.65	3.1	3.52	3.52	4	4	4.4	4.4
Compressor data	Rated current	A	12	14	16.1	6.6	18.2	7.5	20	8.2
	COP	W/W	3.40	3.55	3.98	3.98	4.00	4.00	3.86	3.86
	Quantity		1	1	1	1	1	1	1	1
DC Inverter compressor	Type		Twin-rotary	Twin-rotary	Twin-rotary	Twin-rotary	Twin-rotary	Twin-rotary	Twin-rotary	Twin-rotary
	Brand		Mitsubishi	GMCC	Mitsubishi	Highly	Mitsubishi	Highly	Mitsubishi	Mitsubishi
Fan data	Type		DC	DC	DC	DC	DC	DC	DC	DC
	Quantity		1	1	1	1	1	1	1	1
	Power output	W	75	90	180	90	180	170	180	170
Fan blade	Fan Quantity		1	1	1	1	1	1	1	1
	Air flow	m ³ /h	3300	4000	5500	4000	5500	5500	5500	5500
Physical data	Fin type		Hydrophilic Foil	Hydrophilic Foil	Hydrophilic Foil	Hydrophilic Foil	Hydrophilic Foil	Hydrophilic Foil	Hydrophilic Foil	Hydrophilic Foil
	Number of rows		3	2	2	2.5	3	3	3	3
	Tube type		Inner-grooved copper tube	Inner-grooved copper tube	Inner-grooved copper tube	Inner-grooved copper tube	Inner-grooved copper tube	Inner-grooved copper tube	Inner-grooved copper tube	Inner-grooved copper tube
Refrigerant	Type		R410a	R410a	R410a	R410a	R410a	R410a	R410a	R410a
	Volume	kg	2.00	2.60	3.00	3.00	3.80	3.45	3.80	3.80
Dimension (WxHxD)	Net	mm	935x702x383	1032x810x445	1100x870x528	1032x810x445	1100x870x528	1100x870x528	1100x870x528	1100x870x528
	Packing	mm	975x770x420	1075x875x495	1140x965x540	1075x875x495	1140x965x540	1140x965x540	1140x965x540	1140x965x540
Weight	Net	kg	47	60	85	67.4	90	87.5	90	90
	Gross	kg	50	65	95	72.2	100	97.4	100	100
ODU sound level		dB(A)	≤54	≤56	≤56	≤56	≤57	≤57	≤57	≤57
Operation temp. range	Cooling	Outdoor side	°C	-5-55	-5-55	-5-55	-5-55	-5-55	-5-55	-5-55
	Heating	Outdoor side	°C	-15-30	-15-30	-15-30	-15-30	-15-30	-15-30	-15-30

Note

1. The cooling conditions: indoor temp.:27°C DB(80.6°F), 19°C WB(66°F), outdoor temp.: 35°C DB(95°F)equivalent pipe length:5m drop length:0m.
2. The heating conditions: indoor temp.:20°C DB(68°F), 15°C WB(44.6°F), outdoor temp.:7°C DB(42.8°F)equivalent pipe length:5m drop length:0m.
3. Sound level: Anechoic chamber conversion value, one measured point is 1 m in front of the unit at a height of 1 m. Two measured points are 1 m beside the unit at a height of 1 m. During actual operation, these values are normally somewhat higher as a result of ambient conditions.
4. The above data may be changed without notice for future improvement on quality at performance.

INDOOR UNITS

Provide you with fresh air



Indoor Units line Up

Capacity (kW)	1-way cassette	2-way cassette	Round flow cassette	4-way cassette (Compact type)	Air Handler
2.2	•			•	
2.8	•			•	
3.6	•			•	
4.5	•	•		•	
5.6	•	•	•		
7.1	•	•	•		•
8.0		•	•		
9.0			•		
10.0			•		•
11.2			•		
12.0					
12.5			•		
14.0			•		
15.0					
16.0			•		•

Capacity (kW)	Wall-mounted	Floor Ceiling	Short ceiling concealed ducted unit	Medium ESP ducted unit	High ESP ducted unit	Fresh air processor
2.2	•		•			
2.8	•		•			
3.6	•	•	•			
4.5	•	•	•			
5.6	•	•	•			
7.1	•	•	•	•	•	
8.0		•		•	•	
9.0		•		•	•	
10.0				•	•	
11.2		•				
12.0				•	•	
14.0		•				•
15.0				•	•	
16.0		•				
20.0					•	
22.4						•
25.0					•	
28.0					•	•
45.0					•	•
56.0					•	•

1-way Cassette



Features

Accessories

Plenum box	Air filter	EXV	Drain pump	AC motor	DC motor
/	Standard	Standard	Standard(built-in)	Standard	/

✂ Slim body, easy to install

Has slim body with 250mm height, it is specially suitable for low suspended ceiling rooms.

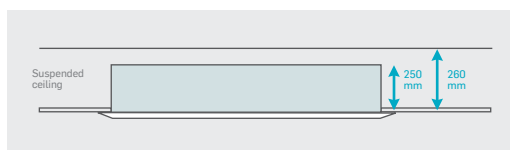

💧 Built-in with drainage pump

Built-in with low noise long life drainage pump, Pumping head is 700mm, flexible for drainage pipe design.

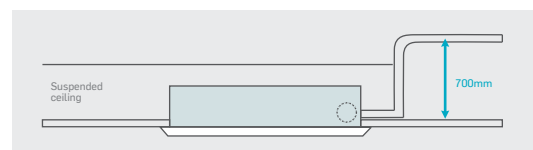

Specification

Model name	Power type	Capacity				Motor input	Air flow	Sound Level	ESP	Dimension(WxHxD)				Body Weight		Connecting pipe			Standard controller
		Cooling kW	Heating kW	Cooling kBTU/h	Heating kBTU/h					Packing mm	Body mm	Panel packing mm	Panel mm	Net kg	Gross kg	Gas mm	Liquid mm	Drain mm	
ZTVC-ECS22BX	50Hz	2.2	7.5	2.5	8.5	0.04	520	306	32-36	1150	985	1090	1070	24/3.6	28/5.0	Φ9.53	Φ6.35	ODΦ25	Remote controller
ZTVC-ECS28BX	50Hz	2.8	9.5	3.2	10.9					1150	985	1090	1070						
ZTVC-ECS36BX	50Hz	3.6	12.2	4.0	13.6					1460	1295	1405	1380						
ZTVC-ECS45BX	50Hz	4.5	15.3	5.0	17.0					1460	1295	1405	1380						
ZTVC-ECS56BX	50Hz	5.6	19.1	6.3	21.4					1460	1295	1405	1380						
ZTVC-ECS71BX	50Hz	7.1	24.2	8.0	27.2	0.09	950	550	38-45	1150	985	1090	1070	35.5/5	40/7	Φ15.9	Φ9.53		

Notes:
 1.Power supply: 220-240V/1N for 50Hz, the above data is for AC motor model.
 2.Cooling test condition: indoor side 27°C DB, 19°C WB outdoor side 35°C DB. Heating test condition: indoor side 20°C DB, 15°C WB outdoor side 7°C DB
 3.Sound level: measured at a point 1.4 m below the unit. During actual operation, these values are normally somewhat higher as a result of ambient conditions.
 4.The above data may be changed without notice for future improvement on quality and performance.

2-way Cassette



Features

Accessories

Plenum box	Air filter	EXV	Drain pump	AC motor	DC motor
/	Standard	Standard(built-in)	Standard(built-in)	Standard	/

↻ 2 way air direction

Two direction air flow, flexibly install in various rooms or hallway

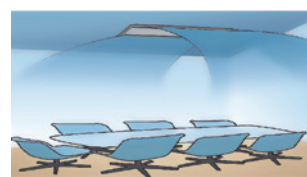

💧 Built-in with drainage pump

Built-in with low noise long life drainage pump, Pumping head is 700mm, flexible for drainage pipe design.

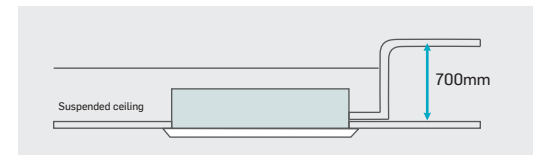

Specification

Model name	Power type	Capacity				Motor input	Air flow	Sound Level	ESP	Dimension(WxHxD)				Body Weight		Connecting pipe			Standard controller
		Cooling kW	Heating kW	Cooling kBTU/h	Heating kBTU/h					Packing mm	Body mm	Panel packing mm	Panel mm	Net kg	Gross kg	Gas mm	Liquid mm	Drain mm	
ZTVC-ECD45BX	50Hz	4.5	15.3	5.0	17	0.07	800	470	36-42	1215	1092	1205	1178	36/5	41/7	Φ12.7	Φ6.35	ODΦ25	Remote controller
ZTVC-ECD56BX	50Hz	5.6	19.1	6.3	21.4					1215	1092	1205	1178						
ZTVC-ECD71BX	50Hz	7.1	24.2	8.0	27.2					1455	1332	1445	1420						
ZTVC-ECD80BX	50Hz	8.0	27.2	9.0	30.7					1455	1332	1445	1420						
										1455	1332	1445	1420						

Notes:
 1.Power supply: 220-240V/1N for 50Hz, the above data is for AC motor model.
 2.Cooling test condition: indoor side 27°C DB, 19°CWB outdoor side 35°C DB. Heating test condition: indoor side 20°C DB, 15°C WB outdoor side 7°C DB.
 3.Sound level: measured at a point 1.4 m below the unit. During actual operation, these values are normally somewhat higher as a result of ambient conditions.
 4.The above data may be changed without notice for future improvement on quality and performance.

4-way Cassette (Compact Type)/Round-flow Cassette



Features

Accessories

Plenum box	Air filter	EXV	Drain pump	AC motor	DC motor
/	Standard	Standard	Standard(built-in)	Standard	Optional

Wide air delivering

Air flow is soft and smooth, air can be delivered to every corner without dead angle, it makes the room temperature distribution more balance.



Space saving installation

It has a slim body with 230mm height, it is specially suitable for low suspended ceiling rooms.(5.6-8.0kW)

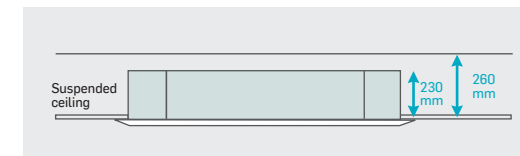

Fresh air intake

Four interfaces to connect with duct to another room. Fresh air intake, aims to provide more healthy and comfortable indoor environment.



Built-in with drainage pump

Built-in with low noise long life drainage pump, Pumping head is 1200mm, flexible for drainage pipe design.

Note: The pumping head of 4-way cassette unit (compact type) is 700mm.

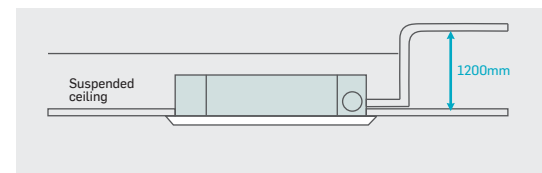

Specification

4-way Cassette Unit(Compact type)

Model name	Power type	Capacity				Power input	Air flow			Sound Level	ESP	Dimension(WxHxD)				Body Weight		Connecting pipe			Standard controller
		Cooling kW	Cooling kBtu/h	Heating kW	Heating kBtu/h		M ³ /h	CFM	DB(A)			Pa	Packing mm	Body mm	Panel packing mm	Panel mm	Net kg	Gross kg	Gas mm	Liquid mm	
ZTVC-ECFC22BX	50Hz	2.2	7.5	2.5	8.5	0.038	447	263	22-34	/	755 x 375 x 680	653 x 267 x 585	750 x 95 x 750	650 x 30 x 650	17.5	23	Φ9.52	Φ6.35	ODΦ25	Remote controller	
ZTVC-ECF22BY	60Hz																				
ZTVC-ECFC28BX	50Hz	2.8	9.5	3.2	10.9	0.038	447	263	22-34	/	755 x 375 x 680	653 x 267 x 585	750 x 95 x 750	650 x 30 x 650	17.5	23	Φ9.52	Φ6.35	ODΦ25	Remote controller	
ZTVC-ECF28BY	60Hz																				
ZTVC-ECFC36BX	50Hz	3.6	12.2	4.0	13.6	0.040	515	303	27-38	/	755 x 375 x 680	653 x 267 x 585	750 x 95 x 750	650 x 30 x 650	17.5	23	Φ12.7	Φ6.35	ODΦ25	Remote controller	
ZTVC-ECF36BY	60Hz																				
ZTVC-ECFC45BX	50Hz	4.5	15.3	5.0	17	0.040	515	303	27-38	/	755 x 375 x 680	653 x 267 x 585	750 x 95 x 750	650 x 30 x 650	17.5	23	Φ12.7	Φ6.35	ODΦ25	Remote controller	
ZTVC-ECF45BY	60Hz																				

Round-flow Cassette

Model name	Power type	Capacity				Power input	Air flow			Sound Level	ESP	Dimension(WxHxD)				Body Weight		Connecting pipe			Standard controller
		Cooling kW	Cooling kBtu/h	Heating kW	Heating kBtu/h		M ³ /h	CFM	DB(A)			Pa	Packing mm	Body mm	Panel packing mm	Panel mm	Net kg	Gross kg	Gas mm	Liquid mm	
ZTVC-ECFE66BX	50Hz	5.6	19.1	6.3	21.4	0.043	860	500	32-39	/	920 x 265 x 985	833 x 232 x 900	1030 x 100 x 1030	950 x 50 x 950	24	30	Φ12.7	Φ6.35	Φ25	Remote controller	
ZTVC-ECFE66BY	60Hz																				
ZTVC-ECFE71BX	50Hz	7.1	24.2	8.0	27.2	0.093	1200	700	35-39	/	920 x 265 x 985	833 x 232 x 900	1030 x 100 x 1030	950 x 50 x 950	24	30	Φ15.88	Φ9.52	Φ25	Remote controller	
ZTVC-ECFE71BY	60Hz																				
ZTVC-ECFE80BX	50Hz	8.0	27.2	8.8	30	0.160	1400	820	37-41	/	920 x 310 x 985	833 x 286 x 900	1030 x 100 x 1030	950 x 50 x 950	24	30	Φ15.88	Φ9.52	Φ25	Remote controller	
ZTVC-ECFE80BY	60Hz																				
ZTVC-ECFE90BX	50Hz	9.0	30.7	10.0	34.1	0.160	1400	820	37-41	/	920 x 310 x 985	833 x 286 x 900	1030 x 100 x 1030	950 x 50 x 950	28.5	35	Φ15.88	Φ9.52	Φ25	Remote controller	
ZTVC-ECFE90BY	60Hz																				
ZTVC-ECFE100BX	50Hz	10.0	34.1	11.0	37.5	0.160	1400	820	37-41	/	920 x 310 x 985	833 x 286 x 900	1030 x 100 x 1030	950 x 50 x 950	28.5	35	Φ15.88	Φ9.52	Φ25	Remote controller	
ZTVC-ECFE100BY	60Hz																				
ZTVC-ECFE112BX	50Hz	11.2	38.2	12.5	42.6	0.160	1400	820	37-41	/	920 x 310 x 985	833 x 286 x 900	1030 x 100 x 1030	950 x 50 x 950	28.5	35	Φ15.88	Φ9.52	Φ25	Remote controller	
ZTVC-ECFE112BY	60Hz																				
ZTVC-ECFE125BX	50Hz	12.5	42.6	14.0	47.7	0.160	1400	820	37-41	/	920 x 310 x 985	833 x 286 x 900	1030 x 100 x 1030	950 x 50 x 950	28.5	35	Φ15.88	Φ9.52	Φ25	Remote controller	
ZTVC-ECFE125BY	60Hz																				
ZTVC-ECFE140BX	50Hz	14.0	47.7	15.0	51.1	0.160	1800	1050	38-46	/	920 x 310 x 985	833 x 286 x 900	1030 x 100 x 1030	950 x 50 x 950	28.5	35	Φ15.88	Φ9.52	Φ25	Remote controller	
ZTVC-ECFE140BY	60Hz																				
ZTVC-ECFE160BX	50Hz	16.0	54.5	17.0	58	0.160	1800	1050	38-46	/	920 x 310 x 985	833 x 286 x 900	1030 x 100 x 1030	950 x 50 x 950	28.5	35	Φ15.88	Φ9.52	Φ25	Remote controller	
ZTVC-ECFE160BY	60Hz																				

Notes:

- 1.Power supply: 220-240V/1N for 50Hz; 208-230V/1N for 60Hz, the above data is for AC motor model.
- 2.Cooling test condition: indoor side 27°C DB, 19°C WB outdoor side 35°C DB. Heating test condition: indoor side 20°C DB, 15°C WB outdoor side 7°C DB.
- 3.Sound level: measured at a point 1.4 m below the unit. During actual operation, these values are normally somewhat higher as a result of ambient conditions.
- 4.The above data may be changed without notice for future improvement on quality and performance.

Short Ceiling Concealed Ducted Unit

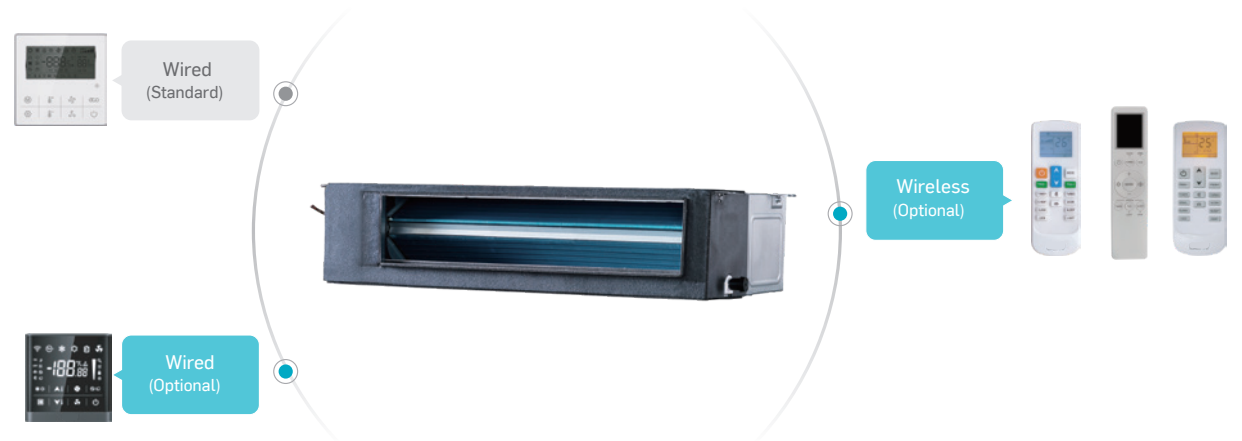

Slim body, easy to install
Has slim body with 210mm height, it is specially suitable for low suspended ceiling rooms.

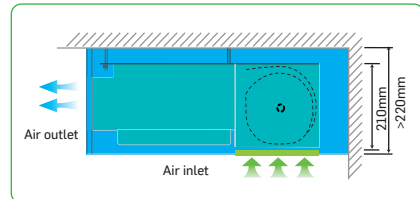

DC fan motor is optional

Integrated design of motor and motor bracket, lower noise

Drain pump is optional
Pumping head is 700mm.



Features

Accessories

Plenum box	Air filter	EXV	Drain pump	AC motor	DC motor
Standard	Optional	Standard (built-in)	Optional	Standard	Optional

Flexible installation

Air return method is optional by actual installation, from rear or from bottom.

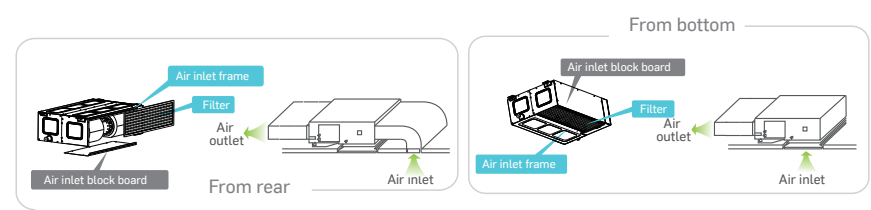

Big air flow low noise centrifugal fan wheel

Big air flow low noise centrifugal fan blade with special air tunnel system, and the unique shock absorption measures, making this series ducted units' running noise is as low as 24 dB(A), let users to enjoy the comfort, sleep without any disturbance.

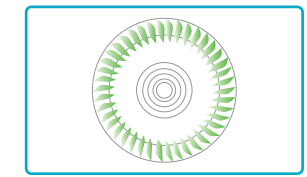
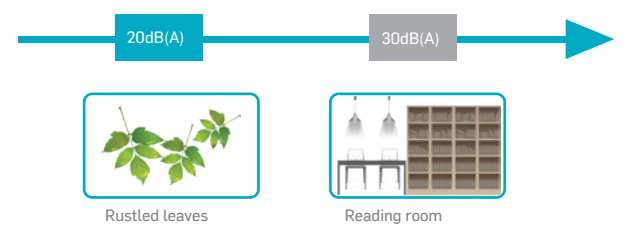

Special resin material fan wheel.

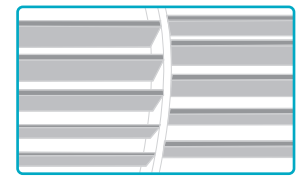

All vanes are dislocation distribution to offset sound wave, so that the noise can be reduced.



High efficiency low noise motor, motor and support frame with rubber ring isolation, can absorb vibration and reduce noise.

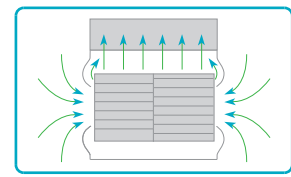

Air inlet of fan wheel casing is arch curved design; it can reduce air flow's disturbance, make if flow smoother to reduce noise.

Specification

Model name	Power type	Capacity				Rated input	Air flow		Sound Level	ESP	Dimension(WxHxD)				Body Weight		Connecting pipe			Standard controller						
		Cooling kW	Cooling kBtu/h	Heating kW	Heating kBtu/h		M ³ /h	CFM			Packing mm	Body mm	Panel packing mm	Panel mm	Net kg	Gross kg	Gas mm	Liquid mm	Drain mm							
ZTVC-EDL22BX	50Hz	2.2	7.5	2.5	8.5	0.08	450	260	24-29	30	910 x 240 x 510	814 x 210 x 467	/	/	17.5	20.0	Φ9.52	/	/							
ZTVC-EDL22BY	60Hz																									
ZTVC-EDL28BX	50Hz	2.8	9.5	3.2	10.9	0.11	550	324	25-32						18.0	20.5				/	/	Φ6.35	/	/	/	/
ZTVC-EDL28BY	60Hz																									
ZTVC-EDL36BX	50Hz	3.6	12.2	4.0	13.6	0.16	620	360	32-37		18.0	20.5	/	/	Φ12.7	/	/	/	/							
ZTVC-EDL36BY	60Hz																									
ZTVC-EDL45BX	50Hz	4.5	15.3	5.0	17	0.16	800	520	28-38		21.5	24.5	/	/	/	/	/	/	/							
ZTVC-EDL45BY	60Hz																									
ZTVC-EDL56BX	50Hz	5.6	19.1	6.3	21.4	0.18	1000	640	30-39		26.5	30.0	/	/	/	/	/	/	/							
ZTVC-EDL56BY	60Hz																									
ZTVC-EDL71BX	50Hz	7.1	24.2	8.0	27.2	0.18	1000	640	30-39	26.5	30.0	/	/	/	/	/	/	/								
ZTVC-EDL71BY	60Hz																									

Notes:
1. Power supply: 220-240V/1N for 50Hz; 208-230V/1N for 60Hz, the above data is for AC motor model.
2. Cooling test condition: indoor side 27°C DB, 19°C WB outdoor side 35°C DB. Heating test condition: indoor side 20°C DB, 15°C WB outdoor side 7°C DB.
3. Sound level: measured at a point 1 m in front of the unit outlet and 1 m below the unit outlet center. During actual operation, these values are normally somewhat higher as a result of ambient conditions.
4. The above data may be changed without notice for future improvement on quality and performance.

Medium ESP Ducted Unit

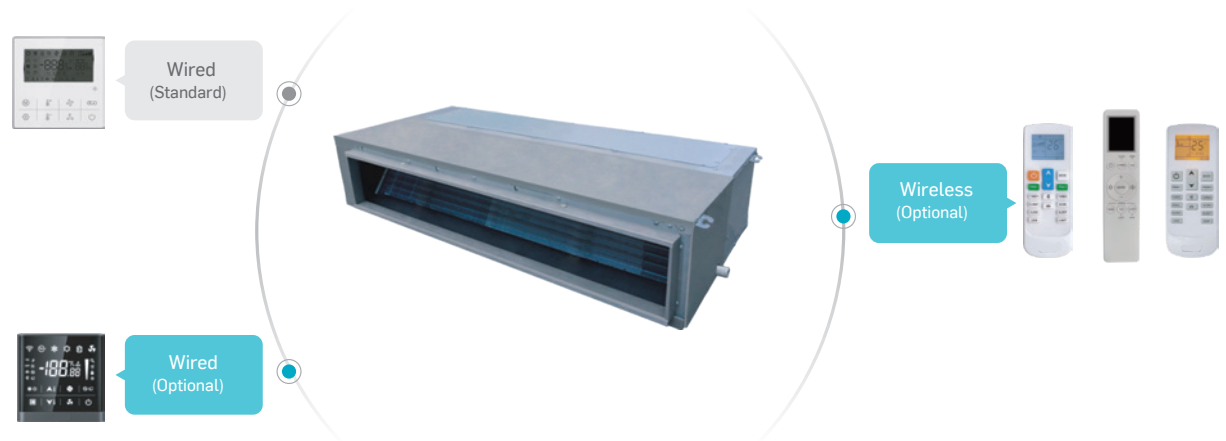

Features

Accessories

Plenum box	Air filter	EXV	Drain pump	AC motor	DC motor
Standard	Standard	Standard	Optional	Standard	Optional

Static pressure

70Pa ESP is standard, suitable for long distance air supply, 30Pa is optional (can be set on site), suitable for low noise requirement rooms.

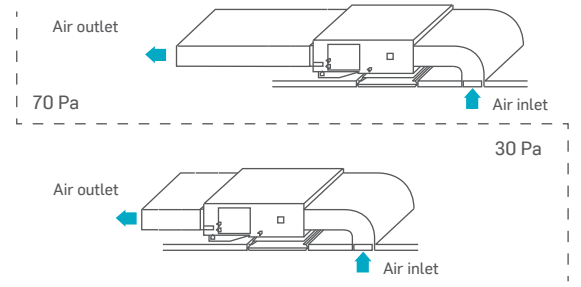

Fresh air intake

A reserved outside air intake port allows outdoor air to be introduced directly into the unit, no need for a separate ventilation system.

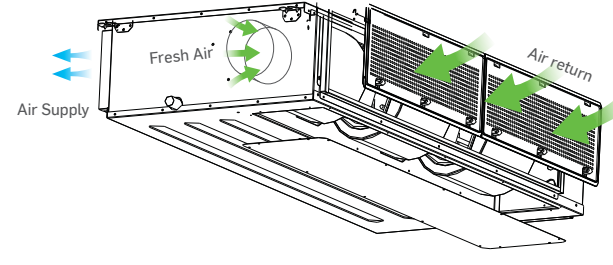

Convenient in drainage pipe installation

Reserved drainage pipe outlet holes on left side and right side, installer can choose the outlet holes on site as per actual conditions, flexible for drainage pipe installation.

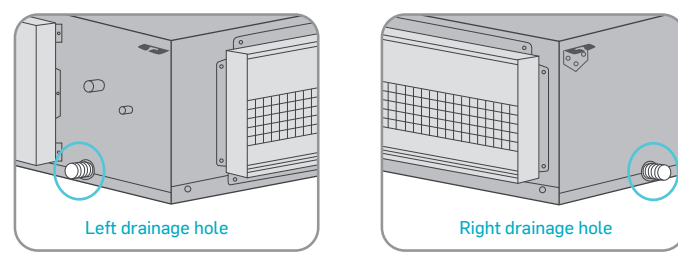

Low noise design

Using multiple noise reduction technology, including the design of high efficiency low noise motor, aviation fan wheel, low vibration wheel casing, unique design, the inner wall configuration with high quality insulation materials, and so on, to make the units running in a low noise condition.

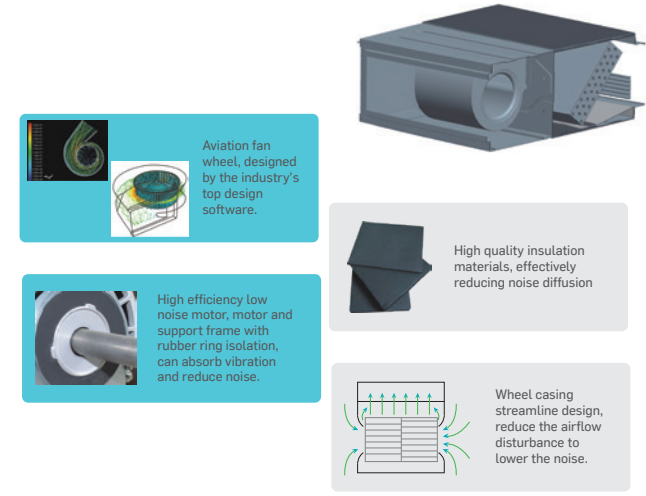

Two air return installation methods

Air return from rear or bottom is easy to change on site, convenient for installation.

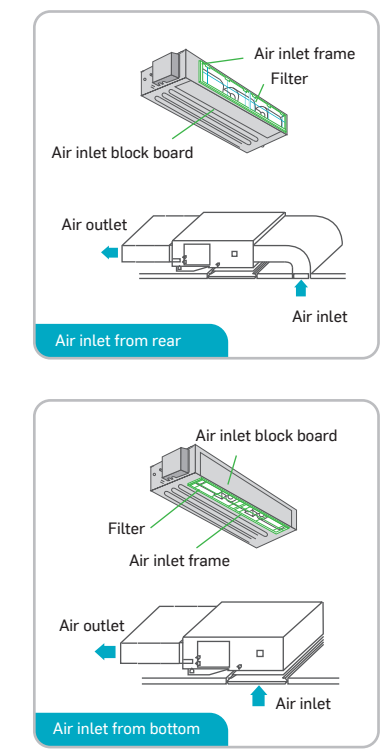

DC fan motor is optional

The power consumption of DC fan motor can be reduced greatly in comparison to corresponding AC type.

Specification

Model name	Power type	Capacity				Rated input	Air flow		Sound Level	ESP	Dimension(WxHxD)				Body Weight		Connecting pipe			Standard controller
		Cooling kW	Cooling kBtu/h	Heating kW	Heating kBtu/h		M ³ /h	CFM			Packing mm	Body mm	Panel mm	Net kg	Gross kg	Gas mm	Liquid mm	Drain mm		
ZTVC-EDM71BX	50Hz	7.1	24.2	8.0	27.2	0.40	1220	710	36-41	70	1255 x 325 x 720	1209 x 260 x 680	/	/	33	37	Ø15.88	Ø9.52	ODØ25	Wired controller
ZTVC-EDM71BY	60Hz																			
ZTVC-EDM80BX	50Hz	8.0	27.2	9.0	30.7	0.40	1850	1080	38-43	70	1490 x 325 x 720	1445 x 260 x 680	/	/	46	50	Ø15.88	Ø9.52	ODØ25	Wired controller
ZTVC-EDM80BY	60Hz																			
ZTVC-EDM90BX	50Hz	9.0	30.7	10.0	34.1	0.40	2000	1170	40-44	70	1490 x 325 x 720	1445 x 260 x 680	/	/	46	50	Ø15.88	Ø9.52	ODØ25	Wired controller
ZTVC-EDM90BY	60Hz																			
ZTVC-EDM100BX	50Hz	10.0	34.1	11.0	37.5	0.40	2000	1170	40-44	70	1490 x 325 x 720	1445 x 260 x 680	/	/	46	50	Ø15.88	Ø9.52	ODØ25	Wired controller
ZTVC-EDM100BY	60Hz																			
ZTVC-EDM120BX	50Hz	12.0	40.9	13.0	44.3	0.40	2000	1170	40-44	70	1490 x 325 x 720	1445 x 260 x 680	/	/	46	50	Ø15.88	Ø9.52	ODØ25	Wired controller
ZTVC-EDM120BY	60Hz																			
ZTVC-EDM150BX	50Hz	15.0	51.1	17.0	58	0.40	2000	1170	40-44	70	1490 x 325 x 720	1445 x 260 x 680	/	/	46	50	Ø15.88	Ø9.52	ODØ25	Wired controller
ZTVC-EDM150BY	60Hz																			

Notes:
 1.Power supply: 220-240V/1N for 50Hz; 208-230V/1N for 60Hz, the above data is for AC motor model.
 2.Cooling test condition: indoor side 27°C DB, 19°C WB outdoor side 35°C DB. Heating test condition: indoor side 20°C DB, 15°C WB outdoor side 7°C DB.
 3.Sound level: measured at a point 1 m in front of the unit outlet and 1 m below the unit outlet center. During actual operation, these values are normally somewhat higher as a result of ambient conditions.
 4.The above data may be changed without notice for future improvement on quality and performance.

High ESP Ducted Unit

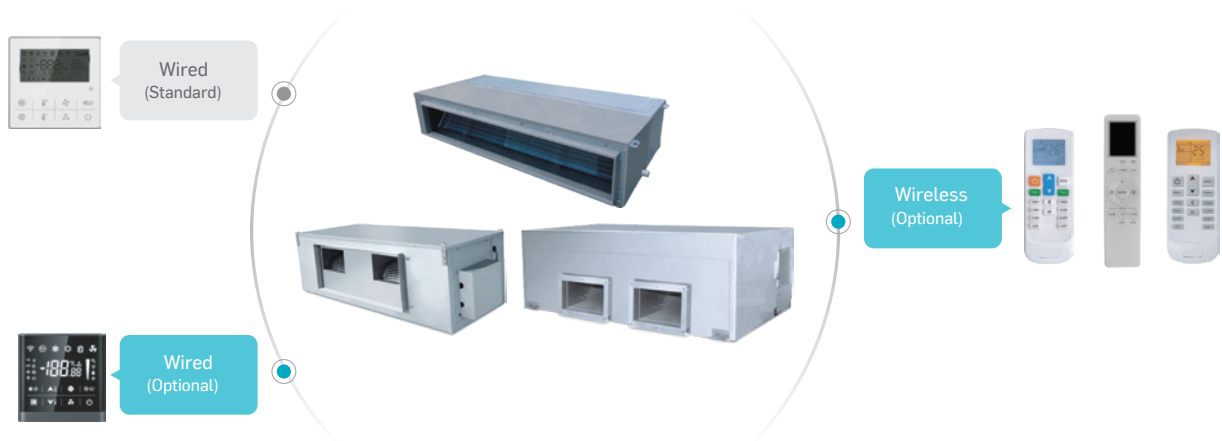

Features

Accessories

Plenum box	Air filter	EXV	Drain pump	AC motor	DC motor
Standard	Standard	Standard	Optional	Standard	/

Optional water pump

Slim body, saving suspended ceiling spaces. And water pump is optional, pump head up to 700mm

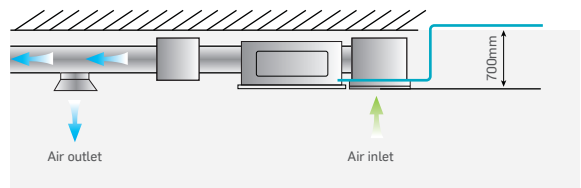

Can be used with various diffusers

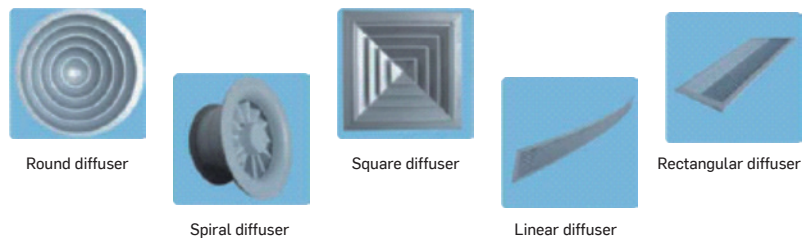

Used with various diffusers, meet for different kinds of decoration.

High static pressure

Big air flow with high static pressure, easy for large rooms duct design. Suitable for different shape of rooms.

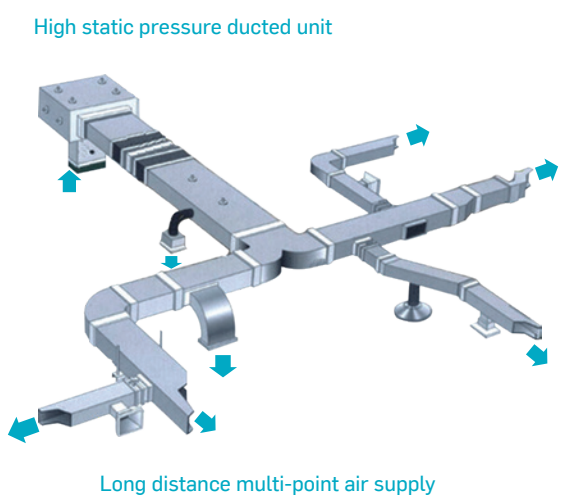

Specification

Model name	Power type	Capacity				Power input	Air flow		Sound Level	ESP	Dimension(WxHxD)		Body Weight		Connecting pipe			Standard controller														
		Cooling kW	Cooling kBtu/h	Heating kW	Heating kBtu/h		M ³ /h	CFM			Packing mm	Body mm	Net kg	Gross kg	Gas mm	Liquid mm	Drain mm															
ZTVC-EDH71BX	50Hz	7.1	24.2	7.8	26.6	0.40	1500	880	40-42	150	1490 x 325 x 720	1445 x 260 x 680	46	50	Ø15.88	Ø9.52	ODØ25	Wired controller														
ZTVC-EDH71BY	60Hz																															
ZTVC-EDH80BX	50Hz	8.0	27.2	8.8	30	0.50	2300	1350	44-52										1245 x 445 x 655	1190 x 370 x 620	47	51										
ZTVC-EDH80BY	60Hz																															
ZTVC-EDH90BX	50Hz	9.0	30.7	10.0	34.1	1.72	4000	2350	45-53																	1510x580x870	1465x448x811	102	113	Ø22.2	Ø12.7	ODØ30
ZTVC-EDH90BY	60Hz																															
ZTVC-EDH100BX	50Hz	10.0	34.1	11.0	37.5	1.20	3750	2200	45-50		1515x885x580	1440x811x448																				
ZTVC-EDH100BY	60Hz																															
ZTVC-EDH120BX	50Hz	12.0	40.9	13.0	44.3	1.72	4200	2470	45-54										1510x580x870	1465x448x811												
ZTVC-EDH120BY	60Hz																															
ZTVC-EDH150BX	50Hz	15.0	51.1	17.0	58.0	1.20	3750	2200	46-51																	1515x885x580	1440x811x448					
ZTVC-EDH150BY	60Hz																															
ZTVC-EDH200BX	50Hz	20.0	68.2	22.0	75.0	1.72	4400	2580	45-55	1510x580x870	1465x448x811																					
ZTVC-EDH200BY	60Hz																															
ZTVC-EDH250BX	50/60Hz	20.0	68.2	22.0	75.0	1.20	3750	2200	46-51								1515x885x580	1440x811x448														
ZTVC-EDH250BY	60Hz																															
ZTVC-EDH280BX	50Hz	28.0	95.5	30.8	105.0	1.72	4400	2580	45-55															1510x580x870	1465x448x811							
ZTVC-EDH280BY	60Hz																															
ZTVC-EDH450BX	50/60Hz	28.0	95.5	30.8	105.0	1.30	4100	2400	48-52	1515x885x580	1440x811x448																					
ZTVC-EDH450BY	60Hz																															
ZTVC-EDH560BX	50Hz	56.0	191.0	63.0	214.9	3.40	8000	4700	64								200	2267 x 840 x 1050	2165 x 676 x 916	222	260	Ø28.6	Ø15.88								ODØ32	
ZTVC-EDH560BY	60Hz																															

Notes:
 1. Power supply: 220-240V/1N for 50Hz; 208-230V/1N for 60Hz.
 2. Cooling test condition: indoor side 27°C DB, 19°C WB outdoor side 35°C DB. Heating test condition: indoor side 20°C DB, 15°C WB outdoor side 7°C DB.
 3. Sound level: measured at a point 1 m in front of the unit outlet and 1 m below the unit outlet center. During actual operation, these values are normally somewhat higher as a result of ambient conditions.
 4. The above data may be changed without notice for future improvement on quality and performance.

Wall Mounted Unit



Features

Accessories

Plenum box	Air filter	EXV	Drain pump	AC motor	DC motor
/	Standard	Standard(built-in)	/	/	Standard

Air supply smoothly

Cross flow fan, In Cooling mode, cold air is blown from horizontal. In heating mode, warm air is blown from vertical.

2 panels can be chosen, suitable for all kinds of decoration style

Simple, elegant, stylish, mirror design, suitable for all kinds of decoration style.

Flexible in installation

Refrigerant pipe can be connected from 3 directions.

Hotel card function

Hotel card interface is standard, which are designed to save energy by only running appliances while guest are present in their room.

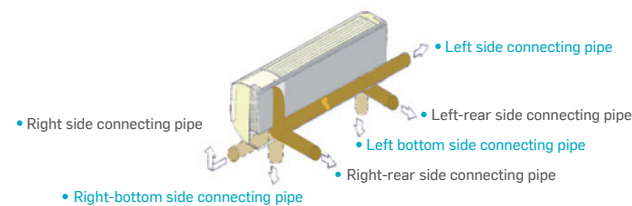

Specification

Model	ZTVC-EHW22DBZ/GSB	ZTVC-EHW28DBZ/GSB	ZTVC-EHW36DBZ/GSB	ZTVC-EHW45DBZ/GSB	ZTVC-EHW56DBZ/GSB	ZTVC-EHW71DBZ/GSB		
Power Supply	220-240V/1N/50&60Hz	220-240V/1N/50&60Hz	220-240V/1N/50&60Hz	220-240V/1N/50&60Hz	220-240V/1N/50&60Hz	220-240V/1N/50&60Hz		
Capacity	Cooling	2.2	2.8	3.6	4.5	5.6	7.1	
	Heating	2.5	3.2	4.0	5.0	6.3	8.0	
Power input	W	15	15	18	20	23	35	
Fan motor	Type	DC	DC	DC	DC	DC	DC	
	Speed (Hi/Med/Low)	r/min	1000/900/870/850	1000/900/870/850	1100/1000/950/900	1050/950/900/850	1100/1000/950/900	1300/1200/1100/1000
Air flow	m ³ /h	440/380/360/350	440/380/360/350	500/440/415/380	655/610/565/525	720/645/580/560	890/805/720/645	
Sound Pressure level	dB(A)	24-33	24-33	27-36	29-38	32-42	35-43	
Body dimension (WxHxD)	Net	mm	864x300x200	864x300x200	864x300x200	972x320x215	972x320x215	972x320x215
	Packing	mm	945x375x290	945x375x290	945x375x290	1060x400x310	1060x400x310	1060x400x310
Body weight	Net/Gross	kg	9.5/12	9.5/12	9.5/12	11.5/14	11.5/14	11.5/14
Refrigerant type			R410A	R410A	R410A	R410A	R410A	
Throttle type			EXV	EXV	EXV	EXV	EXV	
Liquid pipe/Gas pipe	mm		Φ6.35/Φ9.52	Φ6.35/Φ9.52	Φ6.35/Φ12.7	Φ6.35/Φ12.7	Φ6.35/Φ12.7	Φ9.52/Φ15.88
Drainage water pipe (Outer diameter)	mm		Φ20	Φ20	Φ20	Φ20	Φ20	
Operation temperature	℃		16-32	16-32	16-32	16-32	16-32	

Notes:
 1. Power supply: 220-240V/1N for 50Hz; 208-230V/1N for 60Hz.
 2. Cooling test condition: indoor side 27°C DB, 19°C WB outdoor side 35°C DB. Heating test condition: indoor side 20°C DB, 15°C WB outdoor side 7°C DB.
 3. Sound level: measured at a point 1 m in front of the unit outlet and 0.8 m below the unit outlet center. During actual operation, these values are normally somewhat higher as a result of ambient conditions.
 4. The above data may be changed without notice for future improvement on quality and performance.

Wall Mounted Unit



Floor Ceiling Unit



Features

Accessories

Plenum box	Air filter	EXV	Drain pump	AC motor	DC motor
/	Standard	Standard(built-in)	Optional	Standard	Optional

Flexible installation

According to actual project needs, choose ceiling suspended installation or floor standing installation.

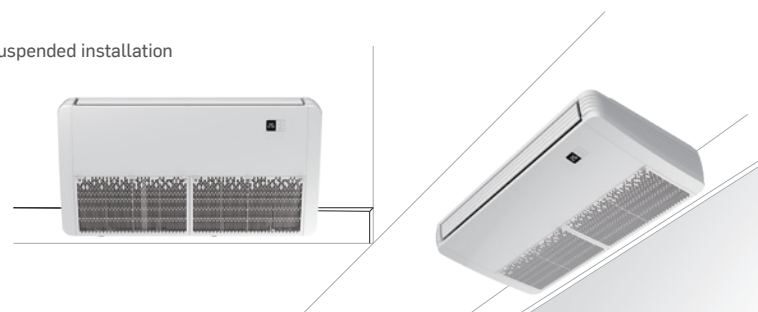

Wide angle air supply

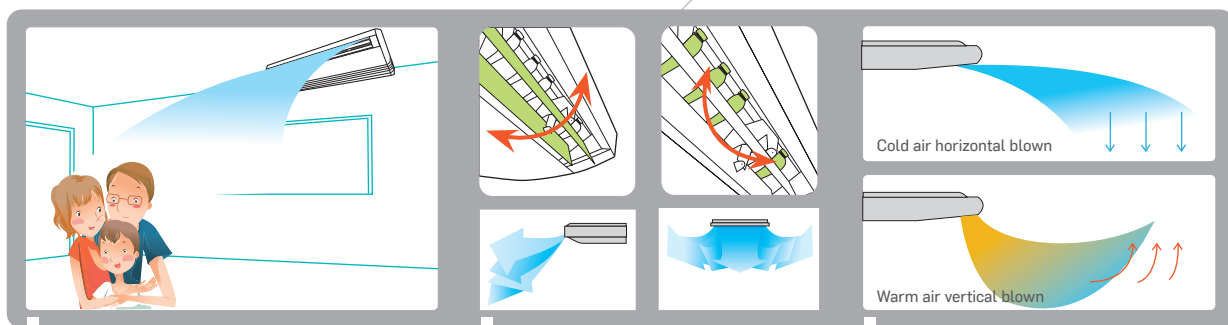

Configured with low noise high performance centrifugal fans, has big air flow and long distance air supply.

3 dimensional air supply, wide air supply angle, easily supply to every corners.

In Cooling mode, cold air is blown from horizontal. In heating mode, warm air is blown from vertical.

Easy for installation

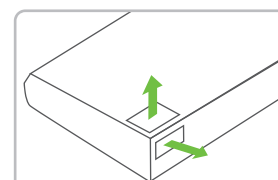

Refrigerant pipe can be connected from 2 directions.

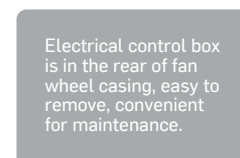

Electrical control box is in the rear of fan wheel casing, easy to remove, convenient for maintenance.

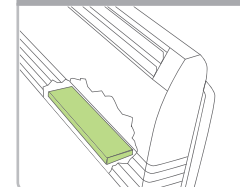

Long term filter can be remove from air inlet grille to clean

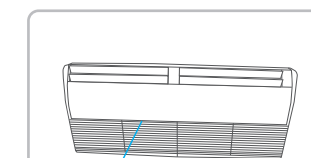

Water washable

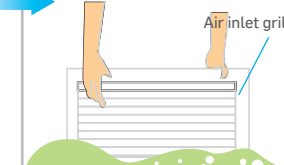

Two kinds of grilles for selection



Horizontal Type Grill (Standard)



Honeycomb Type Grill (Optional)



Specification

Model name	Power type	Capacity				Power input	Air flow	Sound Level	Dimension(WxHxD)		Body Weight		Connecting pipe			Standard controller	
		Cooling	Heating	Packing	Body				Net	Gross	Gas	Liquid	Drain				
		kW	kBtu/h	kW	kBtu/h	kW	M ³ /h	CFM	DB(A)	mm	mm	kg	kg	mm	mm	mm	
ZTVC-EFC36BX	50Hz	3.6	12.3	4.0	13.7	0.085	620	360	37-42	1130 x 765 x 330	1050 x 675 x 235	26.5	31.0	Φ12.7	Φ6.35	DN20	Remote controller
ZTVC-EFC36BY-LDBA	60Hz																
ZTVC-EFC45BX	50Hz	4.5	15.3	5.0	17	0.110	800	470	37-47	1380 x 765 x 325	1300 x 675 x 235	32.0	37.0	Φ15.88	Φ9.52	DN20	
ZTVC-EFC45BY-LDBA	60Hz																
ZTVC-EFC56BX	50Hz	5.6	19.1	6.3	21.4	0.095	1200	706	45-51	1750 x 765 x 325	1670 x 675 x 235	41.0	47.0	Φ15.88	Φ9.52	DN20	
ZTVC-EFC56BY-LDBA	60Hz																
ZTVC-EFC71BX	50Hz	7.1	24.2	8.0	27.2	0.160	1600	940	45-50	1750 x 765 x 325	1670 x 675 x 235	41.0	47.0	Φ15.88	Φ9.52	DN20	
ZTVC-EFC71BY-LDBA	60Hz																
ZTVC-EFC80BX	50Hz	8.0	27.2	8.8	30	0.200	2000	1177	45-54	1750 x 765 x 325	1670 x 675 x 235	41.0	47.0	Φ15.88	Φ9.52	DN20	
ZTVC-EFC80BY-LDBA	60Hz																
ZTVC-EFC90BX	50Hz	9.0	30.7	10.0	34.1	0.200	2000	1177	45-54	1750 x 765 x 325	1670 x 675 x 235	41.0	47.0	Φ15.88	Φ9.52	DN20	
ZTVC-EFC90BY-LDBA	60Hz																
ZTVC-EFC112BX	50Hz	11.2	38.2	12.5	42.6	0.200	2000	1177	45-54	1750 x 765 x 325	1670 x 675 x 235	41.0	47.0	Φ15.88	Φ9.52	DN20	
ZTVC-EFC112BY-LDBA	60Hz																
ZTVC-EFC140BX	50Hz	14.0	47.7	15.0	51.1	0.200	2000	1177	45-54	1750 x 765 x 325	1670 x 675 x 235	41.0	47.0	Φ15.88	Φ9.52	DN20	
ZTVC-EFC140BY-LDBA	60Hz																
ZTVC-EFC160BX	50Hz	16.0	54.5	17.0	58	0.200	2000	1177	45-54	1750 x 765 x 325	1670 x 675 x 235	41.0	47.0	Φ15.88	Φ9.52	DN20	
ZTVC-EFC160BY-LDBA	60Hz																

Notes:

1.Power supply: 220-240V/1N for 50Hz; 208-230V/1N for 60Hz, the above data is for AC motor model.

2.Cooling test condition: indoor side 27°C DB, 19°C WB outdoor side 35°C DB. Heating test condition: indoor side 20°C DB, 15°C WB outdoor side 7°C DB.

3.Sound level: measured at a point 1 m in front of the unit outlet and at a height of 1 m. During actual operation, these values are normally somewhat higher as a result of ambient conditions.

4.The above data may be changed without notice for future improvement on quality and performance.

Fresh Air Processor



Innovative air supply technology for excellent room temperature control

Fresh air unit can be connected with other type indoor units.
Layout Example:

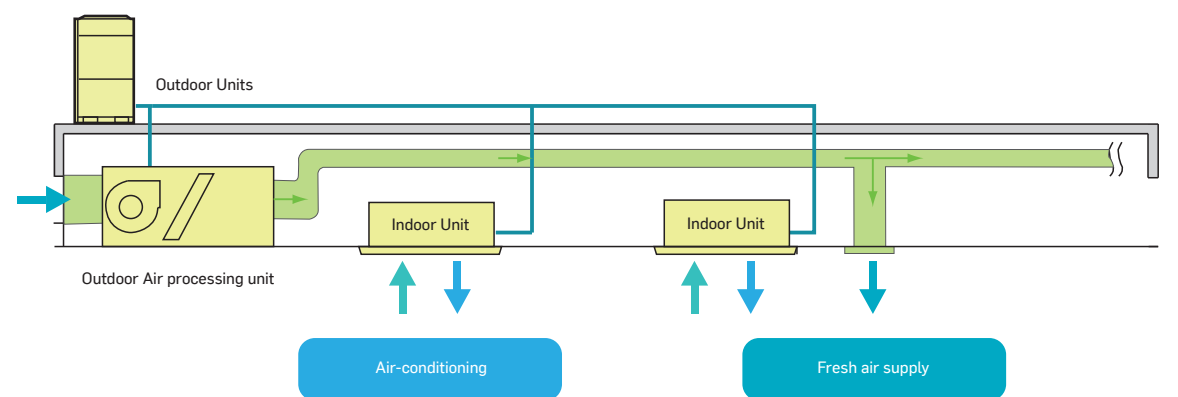

Notes:1. When VRF system connect fresh air indoor unit and other type indoor units together, the capacity combination ratio between indoor unit and outdoor unit should within 100%
2. Fresh air unit capacity can't bigger than 30% of total indoor units capacity.

Features

Accessories

Plenum box	Air filter	EXV	Drain pump	AC motor	DC motor
Standard	Optional	Standard	Optional	Standard	/

Healthy and comfortable environment

Fresh air is imported, provides a healthy and comfortable living environment.

Fresh air processing unit

Both fresh air filtration and heating/cooling can be achieved in a single system. Indoor units and fresh air processing unit can be connected to the same refrigerant system, increase design flexibility and greatly reduce total system costs.

High external static pressure

External static pressure can be up to 300Pa for more flexible duct applications.

Specification

Model name	Power type	Capacity				Power input	Air flow	Sound Level	ESP	Dimension(WxHxD)				Body Weight			Connecting pipe			Standard controller
		Cooling kW	Cooling kBtu/h	Heating kW	Heating kBtu/h					Packing mm	Body mm	Panel packing mm	Panel mm	Net kg	Gross kg	Gas mm	Liquid mm	Drain mm		
ZTVC-EFA140BX	50Hz	14.0	47.7	9.0	30.7	0.45	1400	820	42-48	220	1245 x 445 x 655	1190 x 370 x 620			47	51	Φ15.88	Φ9.52	ODΦ25	Standard controller
ZTVC-EFA140BY	60Hz																			
ZTVC-EFA224BX	50Hz	22.4	76.4	16.0	54.5	1.20	2000	1170	45-52	220	1510 x 490 x 870	1465 x 448 x 811			102	106				Wired controller
ZTVC-EFA224BY	60Hz																			
ZTVC-EFA280BX	50Hz	28.0	95.5	20.0	68.2	1.20	2800	1640	45-52	220	1510 x 490 x 870	1465 x 448 x 811	/	/	102	106	Φ22.2	Φ12.7	ODΦ30	Wired controller
ZTVC-EFA280BY	60Hz																			
ZTVC-EFA450BX	50Hz	45.0	153.5	31.4	107.1	1.60	4000	3520	58	300	2200 x 710 x 1018	2165 x 676 x 916			222	260				Wired controller
ZTVC-EFA450BY	60Hz																			
ZTVC-EFA560BX	50Hz	56.0	191.0	39.0	133.0	2.50	6000	4700	62	300	2200 x 710 x 1018	2165 x 676 x 916			222	260	Φ28.6	Φ15.88	ODΦ32	Wired controller
ZTVC-EFA560BY	60Hz																			

Notes:1.45kW & 56kW units' power supply are 380-415V/3N for 50Hz and 208-230V/3N for 60Hz, the others' power supply is 220-240V/1N for 50Hz and 208-230V/1N for 60Hz
2.Cooling test condition: Indoor and outdoor side 33°C DB, 28°C WB. Heating test condition: Indoor and outdoor side 0°CDB, -2.9°C WB.
3.Sound level: measured at a point 1 m below the unit. During actual operation, these values are normally somewhat higher as a result of ambient conditions.
4.The above data may be changed without notice for future improvement on quality and performance.

Heat Recovery Ventilator



Features

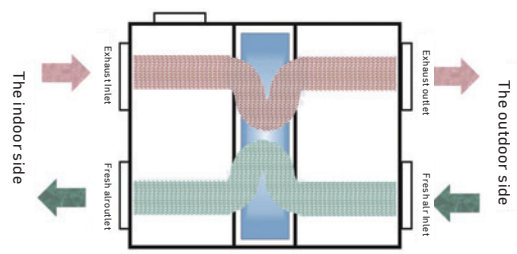

How it works

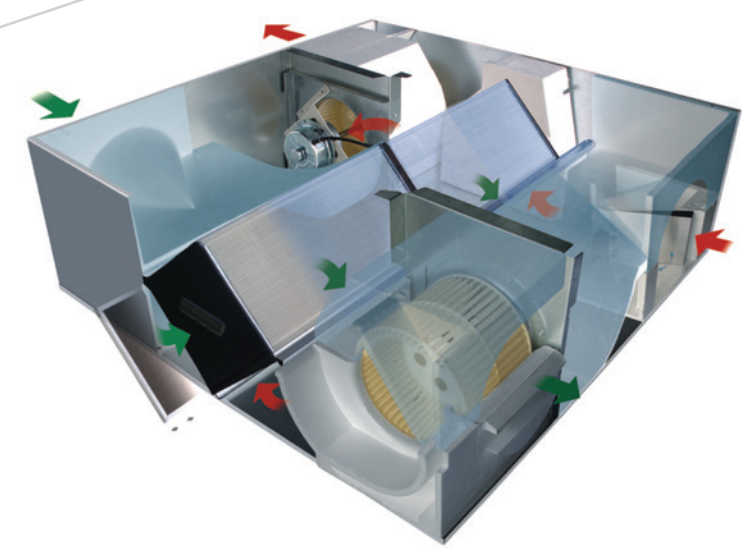

When air flow formed by exhaust air and outdoor air through the heat exchanged core in cross way, because of temperature difference in the two sides of flat partition board, the heat transmission is occurred.

In summer, outdoor air acquire cooling from air exhaust to decrease environment temperature; In winter, outdoor air acquire heating from air exhaust to increase temperature, that is to say, it realizing the energy recovery during air exhaust process to exchange the heating in heat exchanged core to outdoor air.

Application for: business office buildings, hotels, restaurants, meeting rooms, exhibition centres, leisure centres, workshop and other places.

Specification

Suspended type specification

Model name	Air flow M ³ /h	ESP Pa	Power input W	Power supply (V)	Temperature exchanging efficiency(%)		Enthalpy exchanging efficiency(%)		Noise dB(A)	Body dimension (WxDxH) mm	Weight kg	
					Cooling	Heating	Cooling	Heating				
QR-X02D	200	75	65	220V/1N/50Hz	60.0	65.0	50.0	55.0	30	666x580x264	25	
QR-X03D	300	75	130		60.0	65.0	50.0	55.0	33	744x599x270	27	
QR-X04D	400	80	200		60.0	65.0	50.0	55.0	35	744x804x270	30	
QR-X05D	500	80	220		60.0	65.0	50.0	55.0	38	824x904x270	41	
QR-X06D	600	90	242		60.0	65.0	50.0	55.0	40	824x904x270	42	
QR-X08D	800	100	410		60.0	65.0	50.0	55.0	42	1116x884x388	68	
QR-X10D	1000	150	510		60.0	65.0	50.0	55.0	43	1116x1134x388	82	
QR-X13D	1300	150	530		60.0	65.0	50.0	55.0	45	1116x1134x388	82	
QR-X15DS	1500	160	1000		380V/3N/50Hz	60.0	65.0	50.0	55.0	51	1600x1200x540	200
QR-X20DS	2000	170	1200			60.0	65.0	50.0	55.0	53	1650x1400x540	225
QR-X25DS	2500	180	2000	60.0		65.0	50.0	55.0	55	1430x1610x600	240	
QR-X30DS	3000	200	2100	60.0		65.0	50.0	55.0	57	1600x1700x640	270	
QR-X40DS	4000	220	2400	60.0		65.0	50.0	55.0	60	1330x1725x1050	265	
QR-X50DS	5000	240	3000	60.0		65.0	50.0	55.0	61	1660x1820x1050	280	
QR-X60WS	6000	290	3600	60.0		65.0	50.0	55.0	70	1660x1820x1050	310	
QR-X70WS	7000	310	4200	60.0		65.0	50.0	55.0	73	2060x1660x1168	360	
QR-X80WS	8000	320	6000	60.0		65.0	50.0	55.0	74	2060x1660x1168	382	
QR-X90WS	9000	340	7500	60.0		65.0	50.0	55.0	77	2310x1900x1200	500	
QR-X100WS	10000	400	8000	60.0	65.0	50.0	55.0	78	2310x1900x1200	534		

Notes: 1.Cooling test condition: indoor side 27°C DB, 19.5, WB; outdoor fresh air 35°C DB, 28°C;
 2.Heating test condition: indoor side 21°C DB, 13, WB outdoor fresh air 5°C DB, 2°C;
 3.The above data may be changed without notice for future improvement on quality and performance.

Heat Recovery Ventilator



Air Handler Unit



Features

- Insulated cabinet**
 Galvanized steel with paint on all panels. Thermal insulator cover all inside panels to reduce heat and cooling losses and prevent condensed water accumulation.
- Motor & Blower**
 Direct drive motors, 3-speed, provide selections of air flow to meet desired applications. $\Phi 10''$ big fan, powerful wind.
- Coil**
 "A" shape coils, constructed with copper tubing and enhanced aluminum fins.
- Filter optional**
 Detachable air filter for cleaning or renewal.
- Multi-position installation**
 Versatile 4-way convertible design for vertical up airflow, horizontal right airflow.

*Note: Installation of vertical up airflow and horizontal right airflow needs to be customized.

Specification

Model name	Power type	Capacity					Power input	Air flow		Sound Level	ESP	Dimension(WxHxD)		Body Weight		Connecting pipe			Standard controller
		Cooling kW	Cooling kBTU/h	Heating kW	Heating kBTU/h	W		M ³ /h	CFM			DB(A)	Pa	Body mm	Packing mm	Net kg	Gross kg	Gas mm	
ZTVC-EAH71BY	60Hz	7.1	24.1	8.0	27.2	290	1500	882.3	51-54	25	774x520x460	834x520x565	36	39	015.88	09.52	020	Wired Controller	
ZTVC-EAH105BY	60Hz	10.5	35.7	11.5	39.1	290	1500	882.3	51-54	37	774x520x460	834x520x565	36	39	015.88	09.52	020	Wired Controller	
ZTVC-EAH160BY	60Hz	16.0	54.4	18.0	61.2	517	2500	1470.6	57-60	50	970x550x500	1030x560x595	48	52	015.88	09.52	020	Wired Controller	

Notes: 1. Power supply: 208-230V/1N/60Hz;
 2. Cooling test condition: Indoor side 27°C DB, 19°C WB, outdoor side 35°C DB. Heating test condition: Indoor side 20°C DB, 15°C WB, Outdoor side 7°C DB;
 3. Sound level: measured at a point 1 m in front of the unit outlet and at a height of 1 m. During actual operation, these values are normally somewhat higher as a result of ambient conditions.
 4. The above data may be changed without notice for future improvement on quality and performance.



Controllers & Software

Wireless Controllers

- Indoor unit address inquiry
- Indoor unit address setting
- Temperature setting
- Operation mode setting
- Fan speed setting
- Timer function

Wired Controllers



ZKX-C/T/A-06TW

- Bidirectional communication. Indoor unit's operating parameters(error code, temperature, address)can be inquired and displayed on the controller.
- Compact design
- Timer function
- Fahrenheit/centigrade setting
- Address setting
- Press button tone setting

Touch Screen Wired Controller

- Air filter cleaning reminding function.
- Touch screen with black background and blue light
- Ultra thin body and stylish design meet high-end environments.
- On/off, temperature setting, fan speed setting, mode setting, timer and check function.



Simple Centralized Controller



CSP-D184

- Indoor unit operation state
- Indoor unit control order

- Easy to install. Controller connects to outdoor units only.
- 1 Controller can control max. 100 indoor units.
- Mode lock function, user can lock the running mode of indoor unit.
- Build in Modbus protocol.

Smart Manager

- Available on iOS and Android



- Remote control via cloud server



- Single unit controller or group control
- Weekly schedule management
- 100 indoor units can be controlled
- Operation parameter enquiry

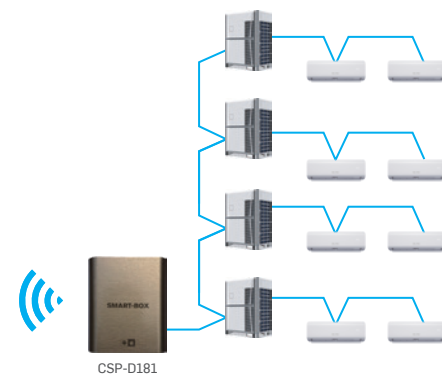

Touch Screen Centralized Controller

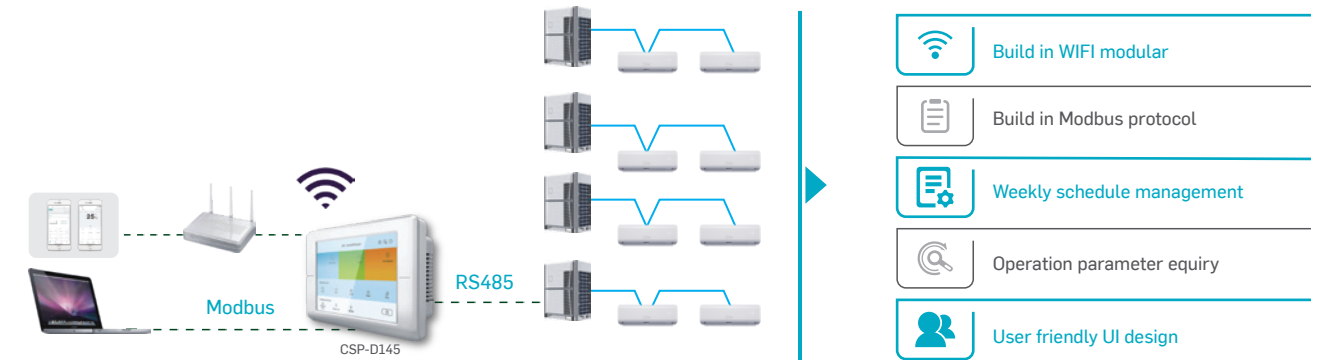

ZTVC-NET(Centralized Control System)

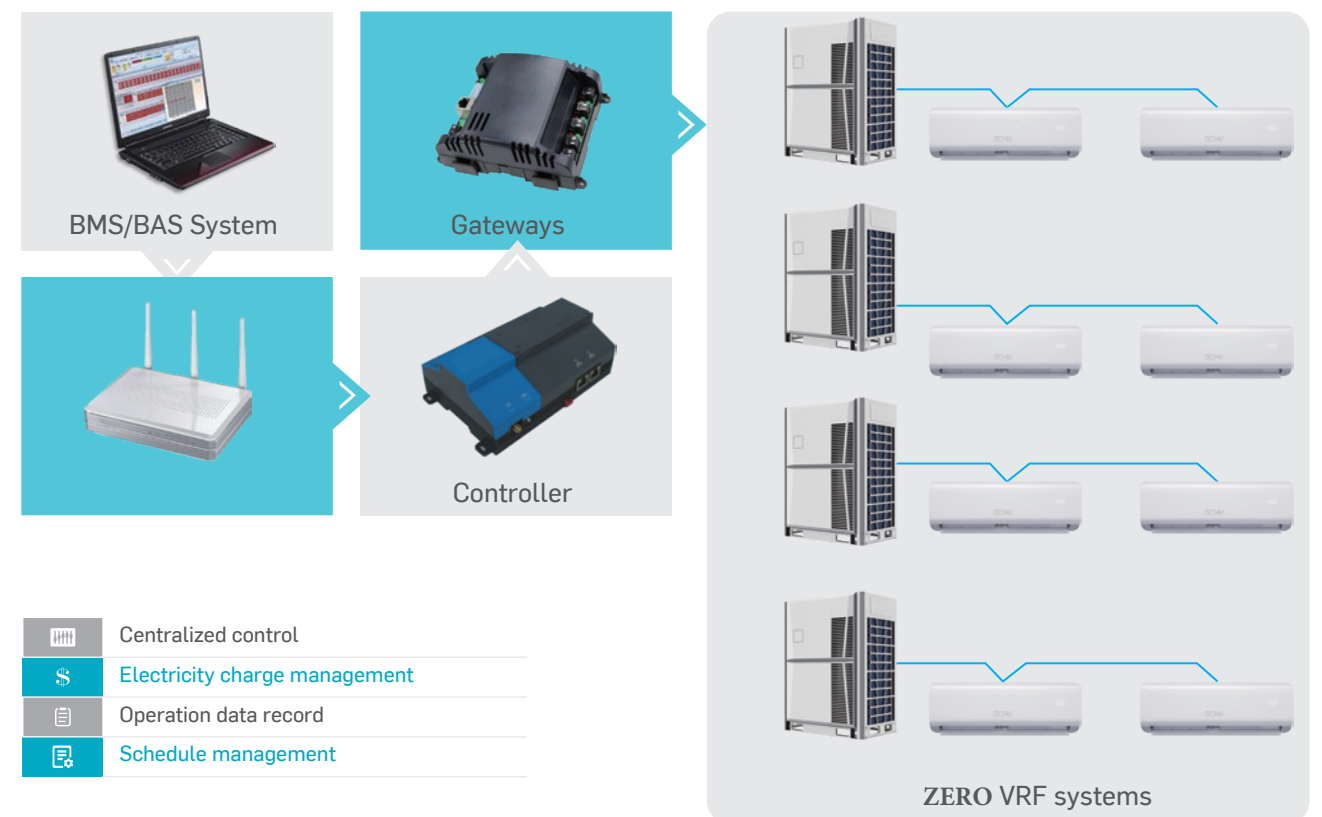

BMS Gateway



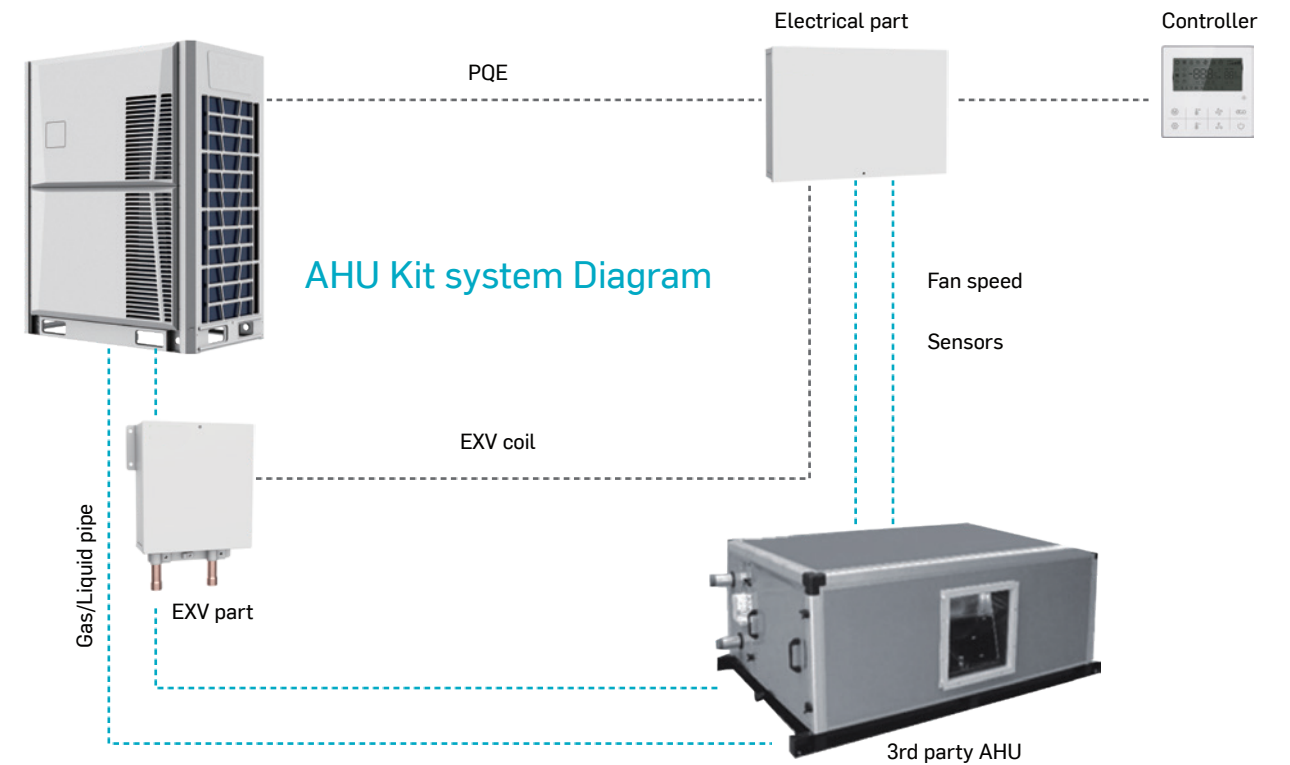
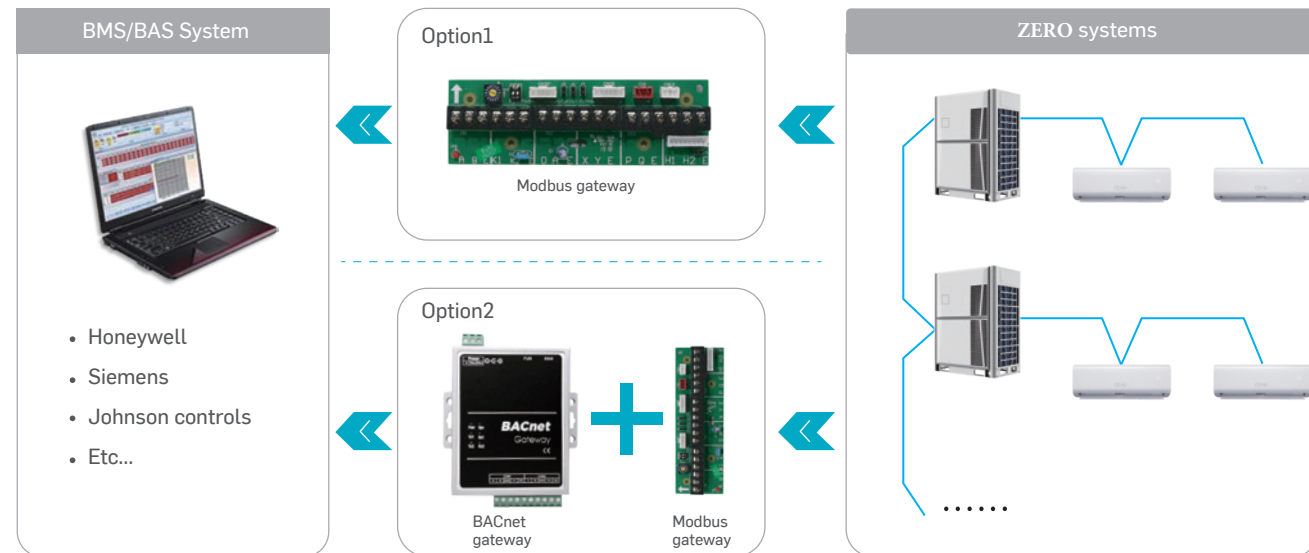

- Modbus gateway** | Independent Modbus Box or built-in with outdoor unit.
- BACnet gateway** | Connect with Modbus gateway, use BACnet IP protocol.



AHU Connection Kit

- ZERO AHU kit** is an interface that allows 3rd party manufacturer's AHU connecting to ZERO VRF outdoor units.
- No address limit and automatic addressing.
- Split type, convenient for installation.
- One electrical part has one address and can max. connect 4 EXV parts.
- One AHU kit can max. connect up to 120HP.

ZERO AHU Kit

<p>Electrical part</p>  <ul style="list-style-type: none"> PCB Power terminals Communication terminals 	<p>EXV part</p>  <ul style="list-style-type: none"> Outlet pipe Inlet pipe EXV 	<p>Sensors & wires</p>  <ul style="list-style-type: none"> T1 sensor and wire T2 sensor and wire T2B sensor and wire Controller wire 	<p>Controller</p> 
---	---	--	--

VRF Selection Software

The selection software provides a comprehensive selection of system design reports and calculations. Base on the units selected, the software produces detailed system layout and piping requirement calculations, greatly improves the work efficiency.

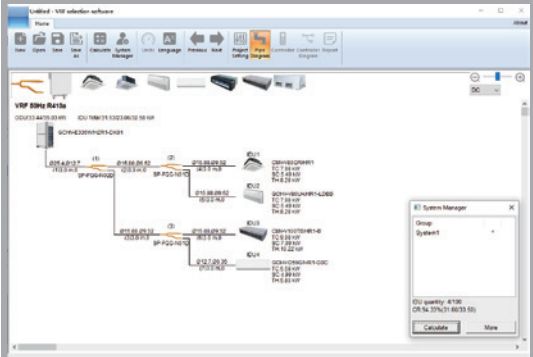
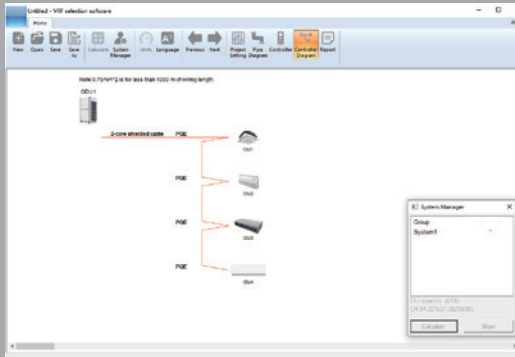
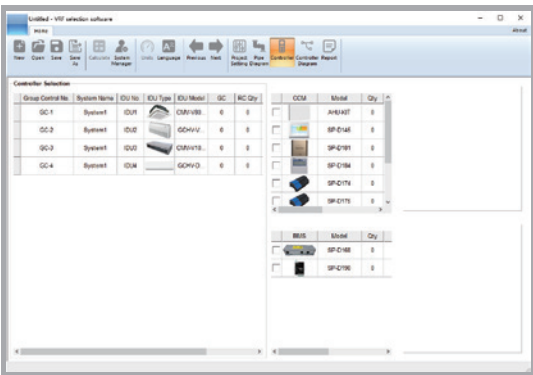
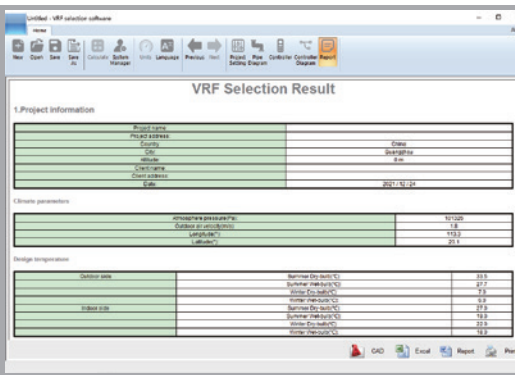
 <p>Piping diagram</p>	 <p>Wiring diagram</p>
 <p>Controller selection</p>	 <p>Report</p>

