

ZTVT *Intelligent VRF*

Full-DC inverter Central air conditioning system

ZERO | ZTVT

Web: www.zerohvacr.com

-  Powerful
-  High efficiency
-  Comfortable
-  Intelligent
-  Stable
-  Convenient



CONTENTS

04 Company Profile

08 Powerful cooling & heating

- DC inverter compressor
- Double C high efficiency condenser
- DC inverter fan motor
- High efficiency axial fan
- supercooling technology
- Air-cooled & refrigeration-cooled technology
- Intelligent inverter technology

14 High efficient energy-saving & environmental friendly

- ODU standby mode
- "2-1" loop design
- Stepless inverter technology
- RoHS certification
- High energy-efficient compressor
- R410A refrigerant
- Variable evaporating /condensing temperature adjustment technology

20 Comfortable & healthy environment

- Extreme fast cooling and heating
- Constant temperature
- Silent-mode
- Healthy air clean strainer
- Fresh air
- Comfortable soft wind
- Intelligent defrost technology
- Auto restart function

26 Intelligent-operation & maintenance control

- Non-polar CAN bus communication technology
- Multiple control solutions
- AHU connection kit
- BMS gateways

32 Stable & reliable performance

- Inverter module cooling protection technology
- Six levels oil return technology
- High precision refrigerant control technology
- -25°C ~ 56°C Ultra wide operating temperature range
- Pressure self-regulating technology
- Triple backup function
- Rotation function
- Multiple protections

42 Convenient Installation and Maintenance

- 15 basic modules, satisfy all kind of requirement
- Big-capacity module design
- Super long refrigerant pipeline design
- Auto-refrigerant detecting and auto-charging function
- Highest static pressure for outdoor unit
- Convenient for the transportation
- Auto-addressing function
- ODU without oil balance pipe, compact design
- Emergency power-off function
- Commissioning software

44 ODU lineup & parameters

60 MINI VRF

67 IDU lineup & parameters

- One-way cassette
- Two-way cassette
- Four-way cassette
- Low static pressure duct
- DC series slim duct
- High static pressure duct
- Wall mounted
- Ceiling & floor
- Fresh air processing
- Energy recovery ventilation

78 Installation options



POWERFUL COOLING AND HEATING

ZTVT full DC Inverter VRF system, use international famous compressor, DC motor, high-precision EXV and so on, thanks to all these high-technology, ZTVT has the best cooling and heating performance.



DC inverter
compressor



DC inverter
fan motor



36°C Three-stage
supercooling technology



Intelligent inverter technology



Double C
high efficiency condenser



High efficiency axial fan



Air-cooled & refrigerant-cooled
technology for main control board





1.1 Full DC Inverter High Pressure Chamber Scroll Compressor

ZERO full DC inverter compressor is built-in with brushless reluctance DC compressor control, DC fan motor, and upgraded heat exchanger, which is more efficient and energy-saving.



Less moving parts



Less moving parts



Fine processing



High efficiency



Less vibration



Long life

1 New scroll compressor
Faster suction and higher efficiency

2 High Pressure Shell
Thicker shells, robust welds and large venting volume reduces sound transmission, lowering overall sound level.

3 Aeronautical Material
Fix scroll is made of aeronautical material, which is light-weighted and durable for high pressure.

4 PTFE Crankshaft
PTFE material is applied to reduce the friction and increase its stabilization.

5 High Polymer Material
PTFE material is applied to reduce the friction and increase its stabilization.

6 I Ball Bearing
Additional ball bearing is applied to due with heavy duty.

7 Recycled Lube
Internal recycle is establish to reduce attenuation of heat and thus, increase the efficiency and stabilization.

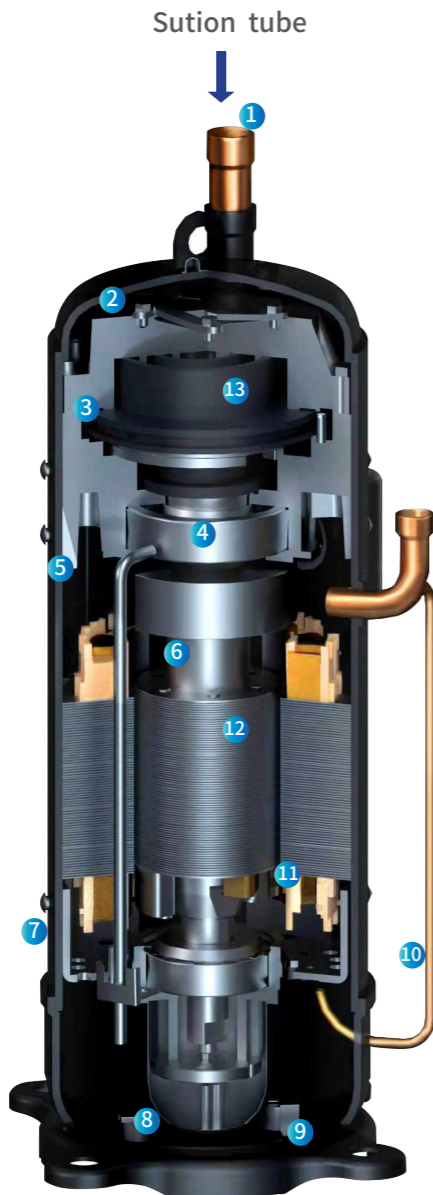

13 Tip Seal of PPS resin
Almost perfect sealing helps to reduce starting torque and efficiency during operation.

12 Permanent Magnet Synchronous DC Motor
NdFeB and optimized structure enable it to be high-efficient, low noise and wide frequency.

11 180° Sine Wave DC Inverter Driver
DC inverter is driven by the pure sine wave which largely increase its efficiency.

10 Active Oil Balancing
Patented active oil balancing technologies ensure the stabilization of usage of multi-connected compressor.

9 Self-cleaning Lube
Strong magnet absorb contamination in the lube and maintain its lubrication.

8 Ball Bearing
Additional ball bearing is applied to due with heavy duty.

>> Asymmetric Vortices

In view of the high pressure characteristics of R410A refrigerant, the compressor strengthens the bearing structure and adopts the design of asymmetric scroll disk, which has the following advantages over the symmetrical scroll disk:

- ✓ Reduce refrigerant leakage and improve efficiency;
- ✓ Two adjacent chambers have small pressure difference, small vibration and more mute;
- ✓ Prevent over compression, prolong the service life of the compressor.

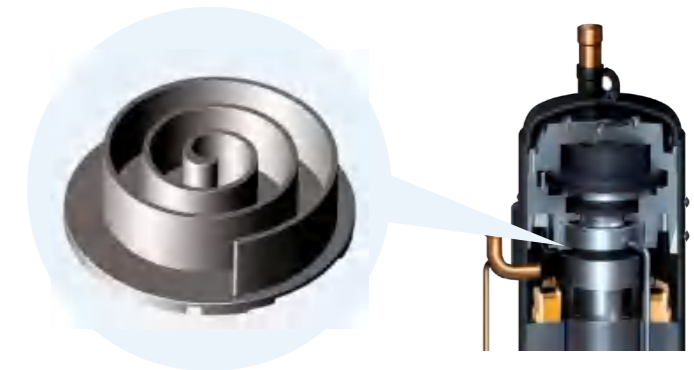

>> Motor Rotor With Neodymium Magnetic Material

Neodymium, an artificial permanent magnet, is one of the strongest magnetic materials to date. The magnetic force of neodymium magnet is 10 times that of common ferrite magnet. Under the same volume, the electromagnetic field intensity is stronger, the starting torque is larger, and the operation efficiency is higher.



>> Large-displacement And ultra-wideband Operation Technology

Displacement up to 98cc, far more than the ordinary compressor (displacement < 80cc), the operation frequency of 10rps-140rps, far more than the ordinary compressor 20rps-100rps, strong power, realizing fast refrigeration and heating.

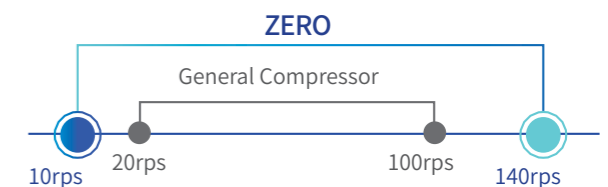

1.2 Double 'C' Type Heat Exchanger

Double C-type compact super-large area heat exchanger, makes the heat exchange area larger, reduces the pressure loss of the heat exchanger, improves the efficiency of heat exchanger, and has higher efficiency when running under heavy load.

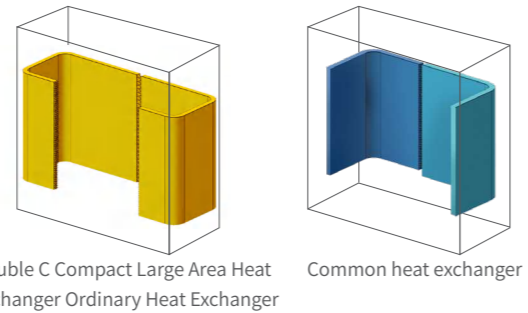

The new structural design further improves the matching of system partial load and reduces the floor area of the whole machine.

36HP occupies only 1.6055 m², which is 21.4% less than the previous generation



Heat exchanger adopts the perfect combination of multi-coated hydrophilic aluminum foil heat exchange fins and high-efficiency internally threaded heat exchange copper tubes, which greatly improves the heat exchange efficiency and enhances the corrosion resistance and oxidation resistance of the heat exchanger.

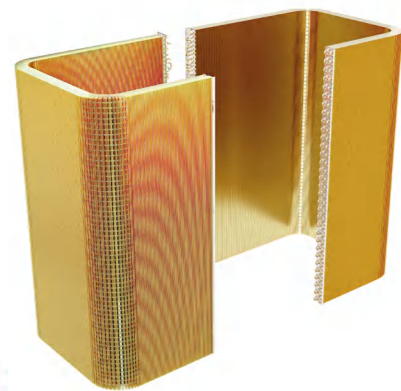

Hydrophilic aluminum fin



Φ7 Heat Exchange Copper Tube

Multiple rows of small-diameter heat exchange tubes, the tube spacing is smaller, and the number of copper tubes used in the same length is more, which effectively increases the heat exchange area of the heat exchanger and improves the heat exchange efficiency of the heat exchanger



Internally threaded copper tubes

The inner surface of the internally threaded copper pipe is designed with a groove, which increases the contact area with the refrigerant, so that the heat exchange performance and thermal conductivity of the heat exchanger are better

- Lubricating layer**
Destroy the surface tension of water droplets, accelerate the downstream speed of condensed water or defrosting water, and improve the air conditioning capacity
- Hydrophilic coating**
Ensure that the air conditioner is not easy to form frost when heating
- Corrosion resistant coating**
Slow down the corrosion of corrosive gas to the heat exchanger
- fin**

The condensed water will spread out quickly on the hydrophilic aluminum foil without condensing into water droplets, increasing the heat exchange area, speeding up the cooling and heating speed, and effectively avoiding the noise caused by the condensed water obstructing the air flow

1.3 High Voltage (concentrated coil) DC Motor

The outdoor unit fan motor adopts a high-voltage centralized winding DC motor, which has a more stable and reliable output, effectively reduces losses and improves operating efficiency.

The outdoor unit fan adopts φ750mm super-size wind wheel, compared with ordinary air conditioner φ540mm dual fans, it has sufficient air volume, higher heat exchange efficiency and lower noise.



1.4 750mm Large Size Axial Flow Fan

The fan is steplessly adjusted according to environmental conditions and air-conditioning load conditions, and is matched with the compressor's stepless frequency conversion technology, so that the system runs more stable and reliable.

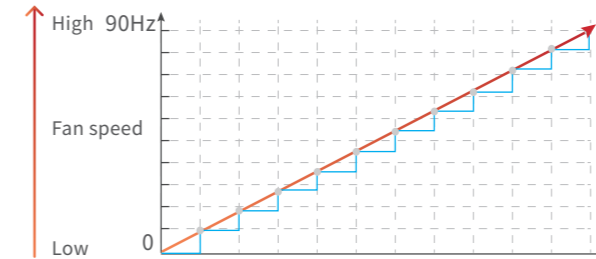

Stepless speed regulation Average speed

1. Accurately adjust the refrigerant pressure to improve the reliability of the unit;
2. The motor speed is adjusted quickly to better adapt to the rapid changes in air-conditioning load.

1.5 Intelligent Inverter

The unit uses multiple sets of high-precision, high-efficiency and high-reliability intelligent inverters to control the compressor and fan motors, making the control more flexible, efficient and intelligent.

Intelligent inverter

- 1) It can effectively reduce high-order harmonic components, motor vibration, torque fluctuation and noise;
- 2) It can ensure the smooth start of the compressor, reduce the starting current of the compressor, and reduce the impact on the power grid; increase the operating frequency range of the compressor;
- 3) Ultra-wide voltage operating range, stable operation within the three-phase 290V-460V voltage range;
- 4) It has multiple protection functions such as undervoltage, overvoltage, overcurrent, and overtemperature to ensure the efficient and reliable operation of the system.



1.6 Surrounding Refrigerant Cooling Technology

The outdoor unit's inverter module is cooled by refrigerant to ensure that the inverter module can be effectively cooled in a high-temperature environment, reduce the working temperature of the frequency conversion module, and improve the reliability and service life of the electronic control system. It also prevents poor heat dissipation under extreme conditions, such as due to the periodic stop of the fan.

Electric control system

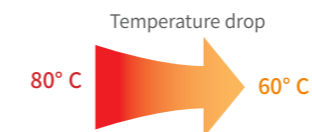

Air cooling heat dissipation

Through the fan (fan) to strengthen the ventilation, strengthen the cooling effect, to maintain stable and reliable system operation.



Refrigerant radiator

The wraparound refrigerant radiator can stably and efficiently take away the heat in the frequency conversion module of outdoor unit, improve the electrical reliability of the unit when working in high temperature environment, and ensure stable and safe operation.

The cooling plate

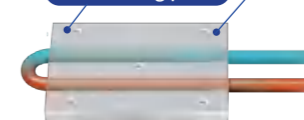

The heat dissipation plate is fitted 360° tightly with the refrigerant tube, effectively reducing the contact thermal resistance between the copper tube and the heat dissipation plate, and the heat dissipation performance is superior.



HIGH EFFICIENT ENERGY-SAVING AND ENVIRONMENTAL FRIENDLY

The global climate is facing severe challenges, in order to achieve the "dual carbon" goal, it has become an urgent issue for enterprises to control carbon emissions effectively, improve energy efficiency and reduce energy consumption. ZERO CAC follows the product design concept of high efficiency, energy saving and low carbon, use high-quality components of efficient refrigeration and leading refrigerating technology, to achieve building air-conditioning systems Integrate the goal of green, reliable and efficient energy management.



ODU standby mode



"2-1" loop design



Stepless inverter technology



RoHS certification



High energy-efficient compressor



R410A refrigerant



Variable evaporating/condensing temperature adjustment technology



1.7 Authoritative Attestation

The ZTVT series full inverter VRF units, through the compressor core frequency conversion technology upgrade, the overall optimization of the refrigeration system and the control system, makes the unit energy-saving performance even better, and has passed the national first-level energy efficiency standard certification.



Certification Bodies' Scheme



Conformite Europeenne

1.8 DC inverter Scroll Compressor

The DC variable frequency compressor adopts an asymmetric scroll structure to effectively reduce the leakage loss of refrigerant gas during suction and inside the compression chamber, to improve the efficiency and reliability of compressor operation.

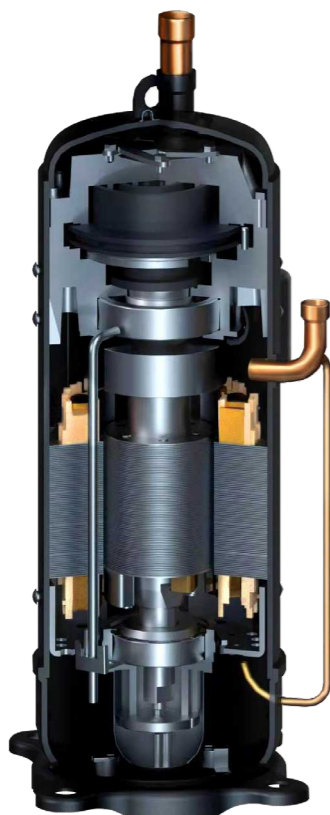

- Optimized asymmetric vortex line**
Using new type of asymmetric scroll profile can reduce leakage loss and ineffective suction overheating.
- Concentrated winding motor**
The coil height of the concentrated winding motor is reduced, the copper loss is less the efficiency is higher in the middle and low speed areas.
- Suction directly**
Small suction preheating, high volume efficiency
- Intermediate pressure servo mechanism**
The intermediate pressure is dynamically adjusted according to the operating pressure to achieve axial flexibility, optimize the orbiting and fixed scroll teeth, and improve product performance.

1.9 High Efficiency "2-1" Refrigerant Flow

Compared with gaseous refrigerant and liquid refrigerant, gas-liquid mixed phase refrigerant has higher heat exchange efficiency. This circuit can not only increase the amount of liquid refrigerant but also increase the flow rate of the refrigerant and increase the heat exchange efficiency.

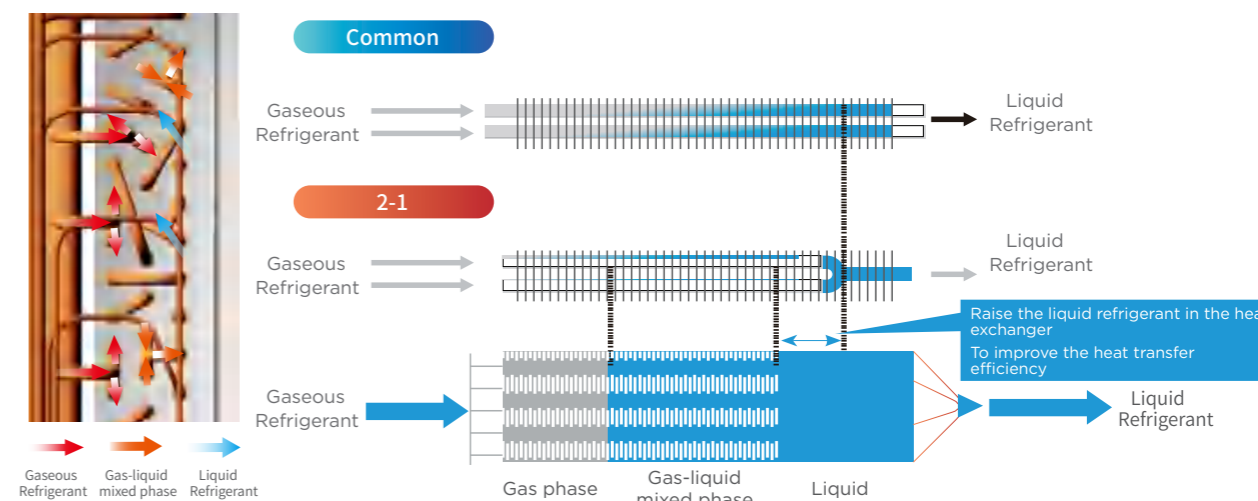

2.0 Variable Evaporating/condensing Temperature Regulation Technology

The self-adaptive adjustment of evaporating and condensing temperature can ensure that when the air conditioner is running, the refrigerant flow can be accurately controlled according to the demand, and the evaporating/condensing temperature can be automatically adjusted to reduce temperature fluctuation, to achieve the effect of energy saving and constant temperature.

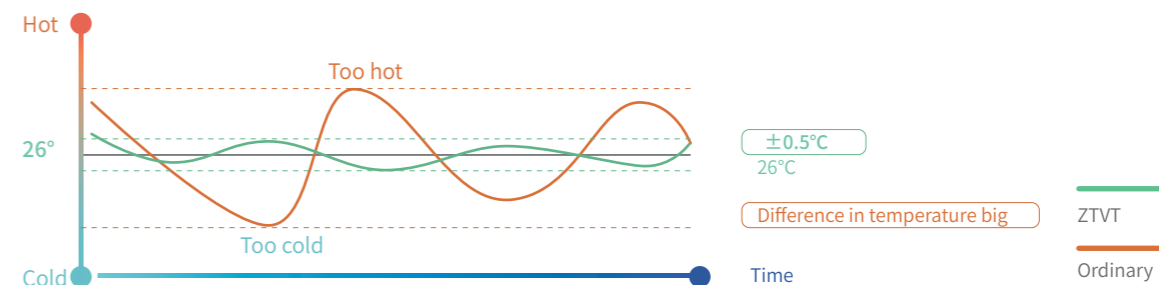

2.10 ~ 480Hz Stepless Frequency Adjustment

- The operating speed of the DC inverter compressor can be adjusted continuously and freely according to the change of the system capacity. The accuracy is higher, the stepless frequency conversion is realized, and the sub-adaptive control technology is combined, and the capacity output is automatically adjusted according to the actual control load to ensure a higher level of accuracy. Smooth change curve to meet higher demands for comfort. ZERO's ZTVT can only use broadband compressors and powerful inverter control motherboards for multiple connections. The compressors operate at 0-480Hz broadband, which has more capacity and can better cope with various complex and harsh extreme conditions.

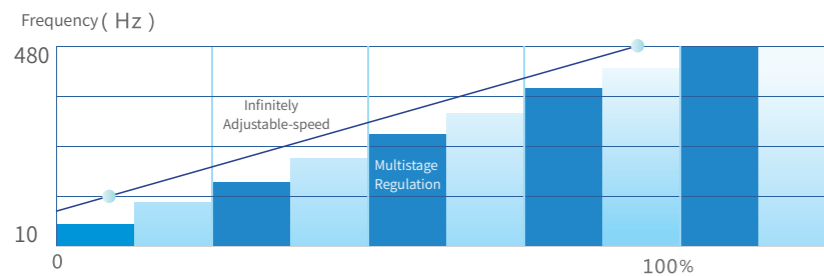

- The compressor adopts 180° sine wave vector drive technology, which can obtain an ideal smooth sine wave curve, so that the motor runs smoothly, the electric energy efficiency is higher, and the harsh sound is reduced.
- Vector control technology effectively suppresses high magnetic harmonic current and electromagnetic noise, and has passed the national EMC electromagnetic interference test

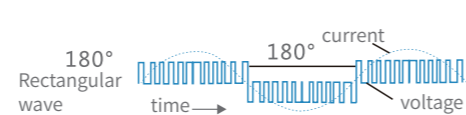
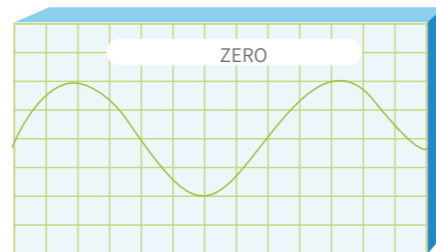
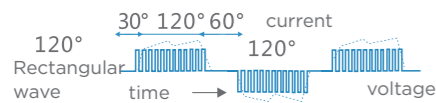
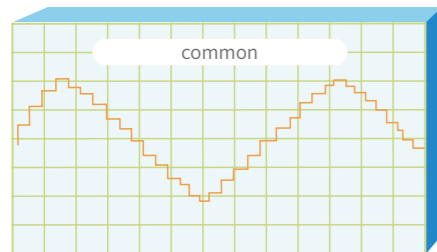

2.2 Four Seasons Energy-saving Mode

- Select the automatic energy-saving mode, the system optimizes output according to changes in ambient temperature, realizes automatic control of energy-saving in all seasons, and improves the overall energy efficiency of the unit's all-season operation.

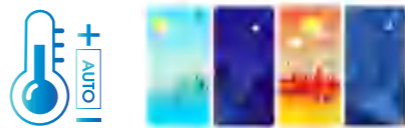

2.3 ODU Standby Mode

- When there is no need for cooling and heating indoors, the control system issues a command to cut off the power supply of the outdoor heating and power devices of the electric control module. The standby power of the outdoor unit is as low, which is low-consumption and energy-saving.



2.4 Multi-priority Modes, VIP Priority Service

- The ZTVT system can be set with a variety of operating modes, cooling only/heating only/cooling priority/heating priority/VIP priority/first opening priority to prevent mode conflict.



Response only cooling



Respond only heating



Cooling priority



Heating priority



VIP priority

2.5 R410A High-efficiency Environmentally Friendly Refrigerant

- R410A is an HFC refrigerant that does not damage the ozone layer. Using R410A can increase the COP and protect the ozone layer. It is an efficient and environmental-friendly refrigerant.
- R410A is non-toxic and is a "non-flammable refrigerant".



2.6 RoHS Certification

- ZTVT full inverter VRF unit is highly efficient and environmentally friendly. Seiko builds global quality and has passed EU RoHS certification.

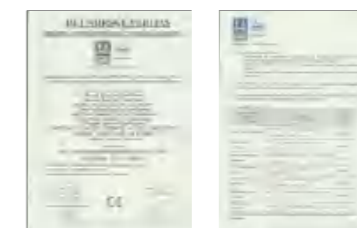



COMFORTABLE AND HEALTHY ENVIRONMENT

People's demand for a healthy air environment is constantly escalating. The improvement of air quality in buildings is more and more important. ZERO intelligent VRF has been seeking technical innovation to provide people with a comfortable and clean, healthy air environment to build people's high-quality life.



Extreme fast cooling and heating



Constant temperature



Silent-mode



Comfortable soft wind



Fresh air



Auto restart function



Intelligent defrost technology





2.7 Fast Cooling And Heating

- ZERO VRF adopts a large-capacity DC inverter compressor which can start the unit quickly and achieve a super cooling and heating capacity output, to provide a comfortable room environment.

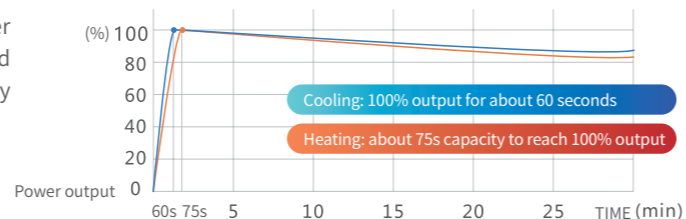

2.8 Constant Temperature

- Multiple sensors detect the real time temperature of the system to make sure the indoor temperature fluctuation within $\pm 0.5^{\circ}\text{C}$.

Multi-electronic Expansion Valves

- The outdoor unit has multiple electronic expansion valves with a control accuracy up to 3000 level(optional), which can adjust the refrigerant circulation and control the compressor overheat accurately to get a precise temperature control.

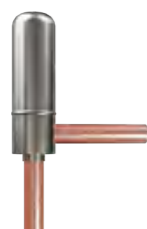

Electronic expansion valve

High control accuracy
3000 Level(optional)

High-precision temperature sensor

- Can detect accurate temperature with precision $\pm 0.5^{\circ}\text{C}$



Dual pressure sensors

- High precision and sensitivity can detect the pressure fluctuation quickly and accurately.



Refrigerant liquid by-pass technology

- This technology is mainly used to increase the refrigerant flow and improve the cooling effect when the indoor side refrigerant flow is insufficient.

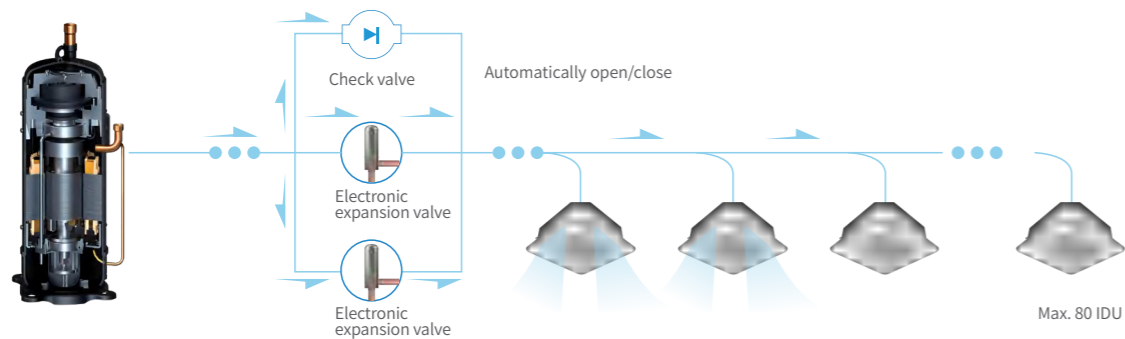

2.9 Multiple Silence Technology

13 Items of silent improvements

The structure of each component is involved in optimized airflow analysis, which can not only operate with low noise, but also ensure the air volume and operation effect of the outdoor unit.

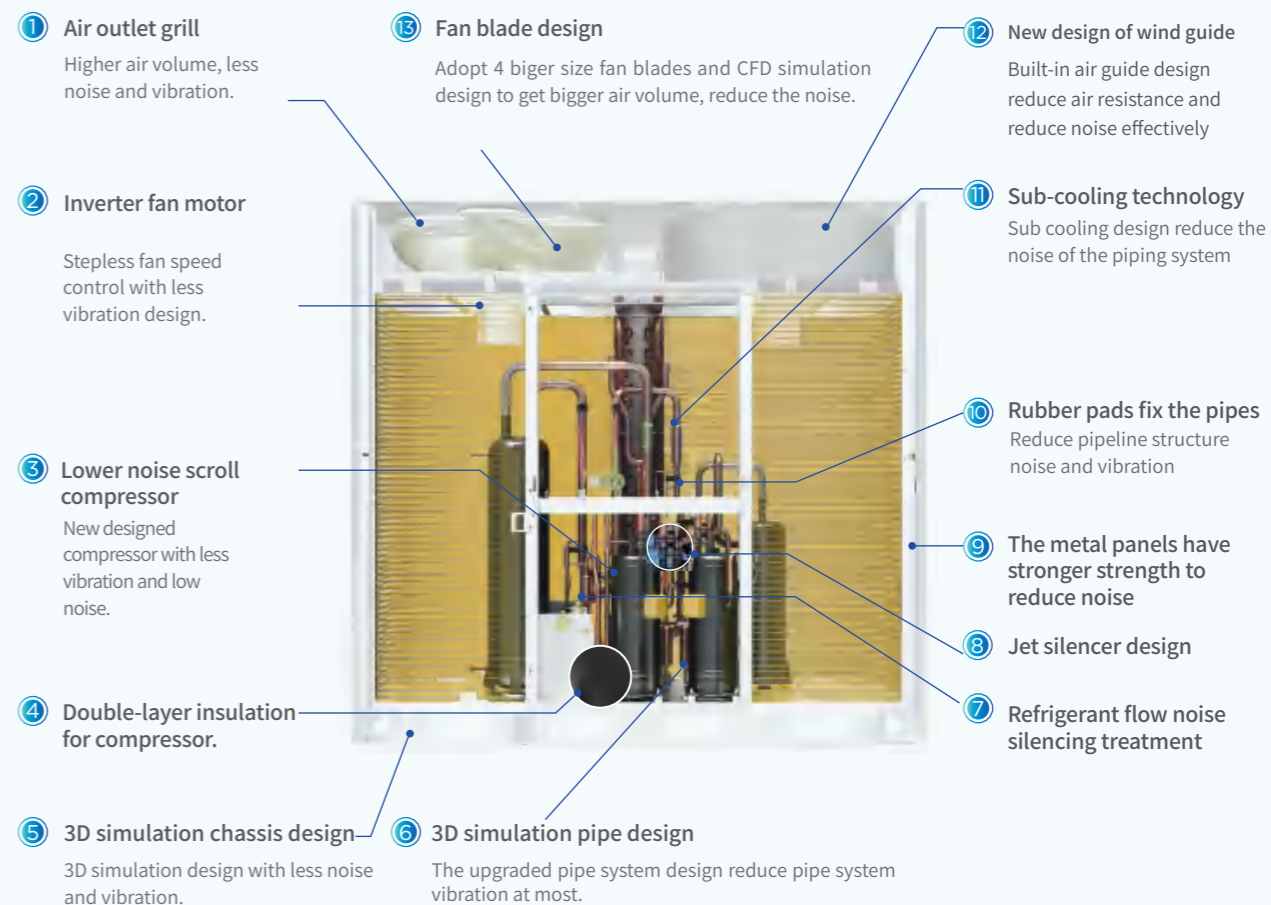

Night silent mode

- The ODU can automatically check the highest ambient temperature and record the time, then to start the silent operation mode after 8 hours, system returns to the normal mode after running for 10 hours. To make the ODU running noise to as low as 45dB(A).

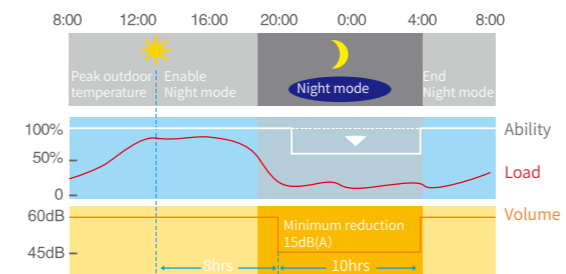

Super silent mode

- In this mode, the running noise of the system will be reduced to be 40dB(A).

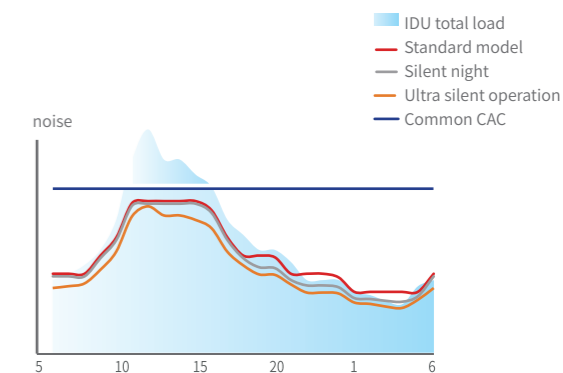



3.0 Fresh Air Solution

- ZERO VRF can supply the multiple fresh air solutions such as fresh air processing units , ERV and air handing units etc.



3.1 Comfortable Soft Wind Panel(optional)

- The upgraded panels have a beautiful appearance and provide comfortable air supply .



3.2 Intelligent Auto-restart Function

- When a sudden power failure occurs, system will automatically store the state of the machine before the power failure. When the machine is restarted, the system will automatically restart with the settings before the power failure (operation mode, set temperature, fan speed, etc.)

Note: This function can also start manually

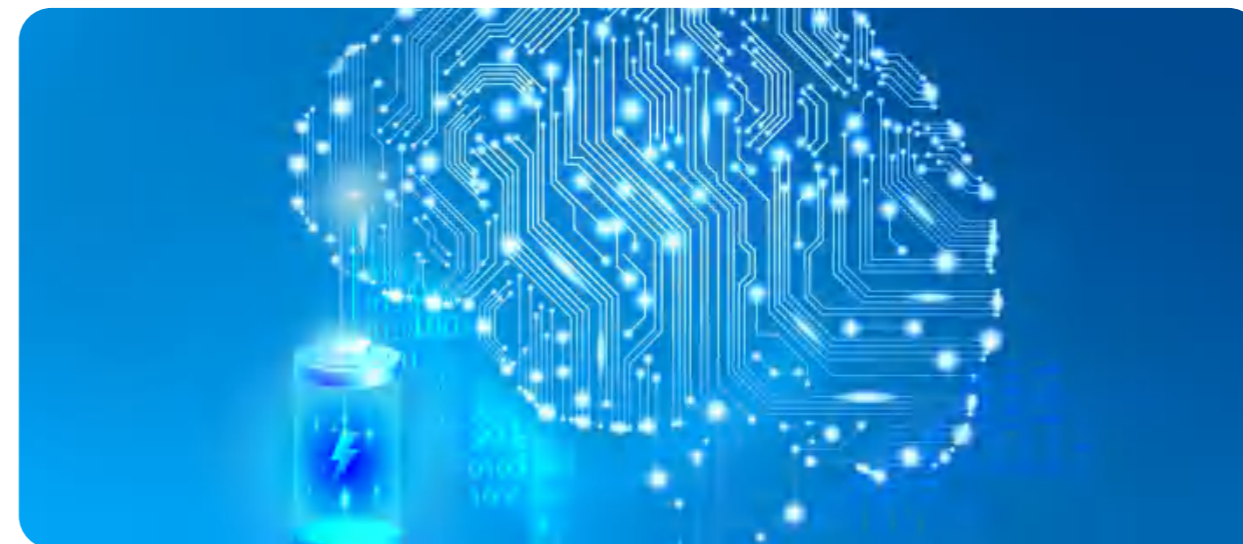

3.3 Intelligent Defrost Technology

- The system can automatically decide the time to defrost according to the operation data and heating capacity.
- Under high humidity condition, the system will defrost in advance to keep the room comfortable.
- During defrosting, the system will close the indoor to avoid the cold air .

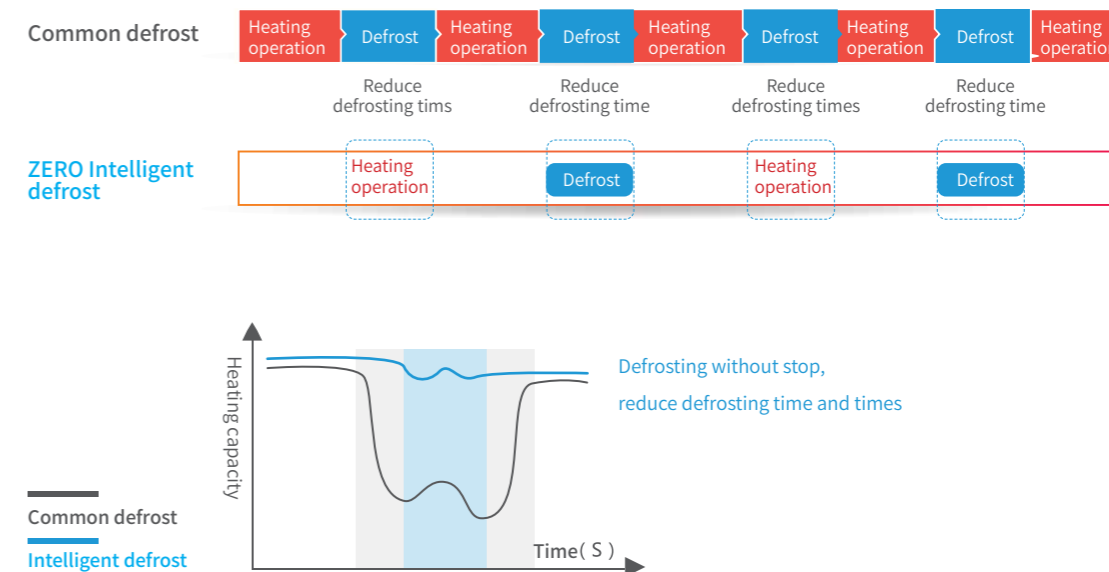

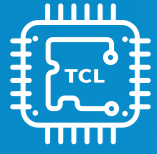

INTELLIGENT - OPERATION AND MAINTENANCE CONTROL

ZERO full DC inverter VRF systems can provide the intelligent operation and maintenance functions, which provides an efficient solution for the intelligent operation and maintenance of buildings, It ensures energy-saving and high-efficient operation and intelligent management.

CAN Non-polar CAN bus communication technology

 Multiple control solutions

 VRF WiFi & APP control solution

AHU AHU connection kit

 BMS gateways





3.4 Intelligent Control

Smart commissioning

- During installation, the system automatically detects the number of indoor and outdoor units, communication link status, and real-time feedback of installation abnormalities, making installation simple and easy.

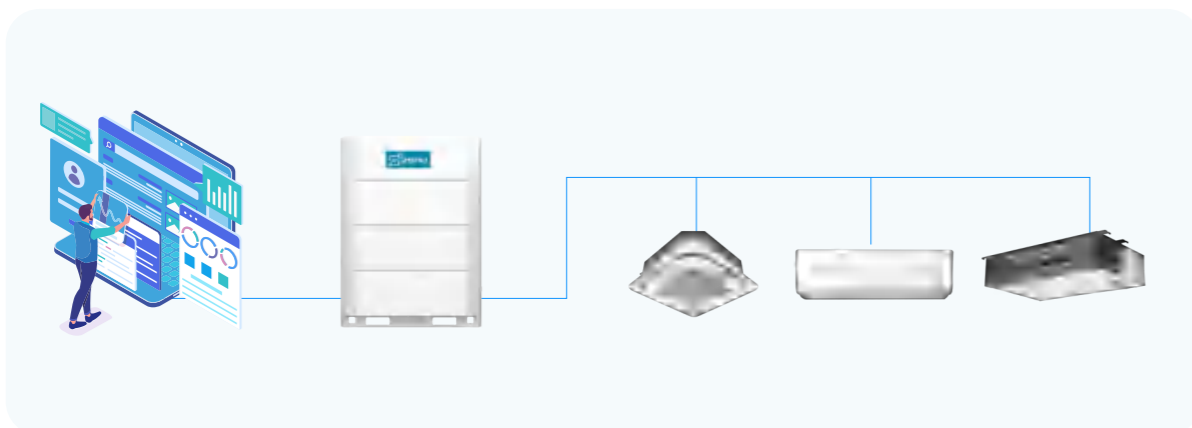

Intelligent detection

- When the equipment is running, the system records the best running status intelligently. And it will adjust the compressor frequency and the step of the EXV for next time automatically.



Smart detection

- During system operation, data will be recorded, abnormalities will be automatically detected and raised.



3.5 Non-polar CAN bus Communication Technology

- ZTVT adopts CAN bus communication technology, which is a communication technology applied in the field of automobile and military industry.

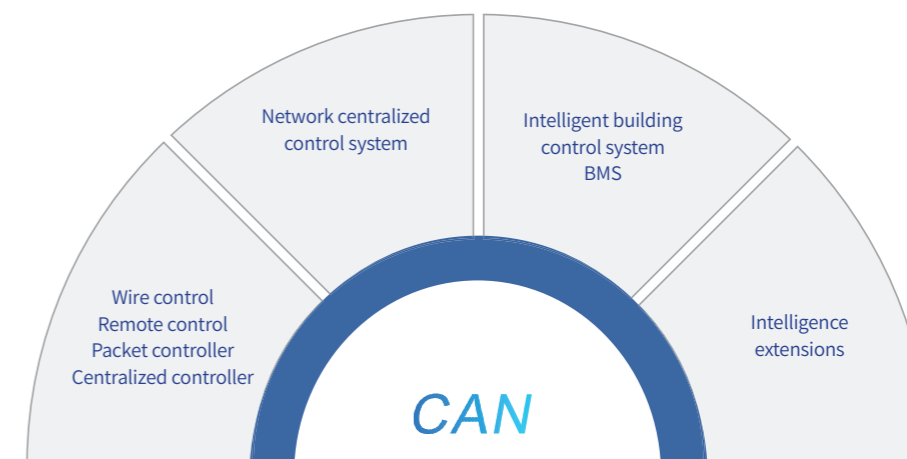

	ZTVT VRF(CAN communication)	Other similar products in the industry(RS 485 communication)
Reliability	High reliability and stable network	The reliability is unstable and easy to be paralyzed
Communication efficiency	Up to 100kbs	About 10kbs
Communication distance	About 2000m	About 1000m
Communication line polarity	No polarity, easy to debug	Polarities need to be distinguished for installation
Scalability	Easy to plug and play	To add new device, the software must be changed, and the scalability is poor



3.6 Multiple Control Solutions

ZTVT provides a variety control solutions for customers to choose.



Remote Controller

- Cooling / dehumidification / fan / heating / automatic and other operation settings
- Temperature / fan speed setting
- Sleep/timer/swing/turbo and other functions



Wired Controller

- Cooling / dehumidification / fan / heating / automatic and other operation settings
- Temperature / fan speed setting
- Sleep/timer/swing/turbo and other function settings
- Monitoring function, big LCD screen displays the operation status of the unit
- Remote control signal available



Central Controller

- 7 inches and colorful screen display, beautiful appearance, touch screen, easy operation.
- A variety of combinations, single or multiple machines can be operated simultaneously.
- Up to 16 systems and 1280 indoor units can be connected, easy to set indoor units parameters.
- It also has the schedule setting and historical fault query function.

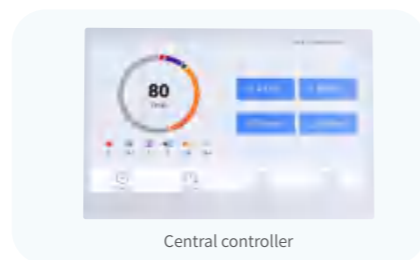

3.8 AHU Connection KIT

Solution to extend ZERO VRF technology to third party Air Handling Units.

- ✓ Easy for connecting to third party AHU
- ✓ Setting capacity by DIP
- ✓ Remoter or wire controller can be chosen
- ✓ 3 steps fan motor speed, Low/Mid/High
- ✓ Error status: No error or error occurred

Communication wire

Refrigerant pipe

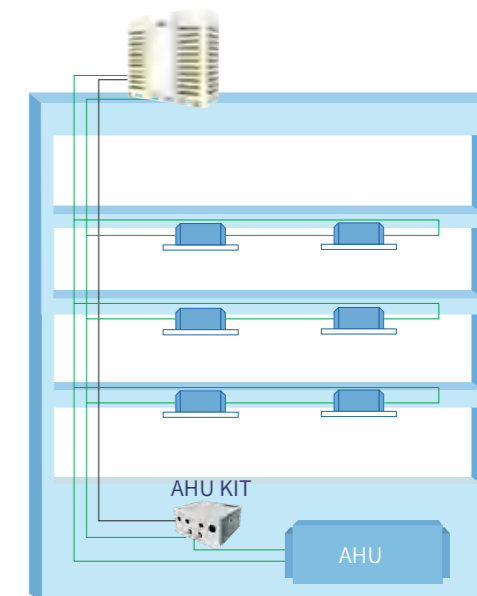

Type	Model Name	Capacity	Pipe dimension	Combination				Description
				ODU	Motor	Pump	Warning signal	
Communication Kit	CTVT-AK1	8-20Kw	Φ7.94	ZTVT	✓	✓	✓	Room air supply by remote controller or wiring controller
	CTVT-AK2	20-40Kw	Φ12.7		✓	✓	✓	
	CTVT-AK2	40-65Kw	Φ15.88		✓	✓	✓	

3.9 BMS Gateways

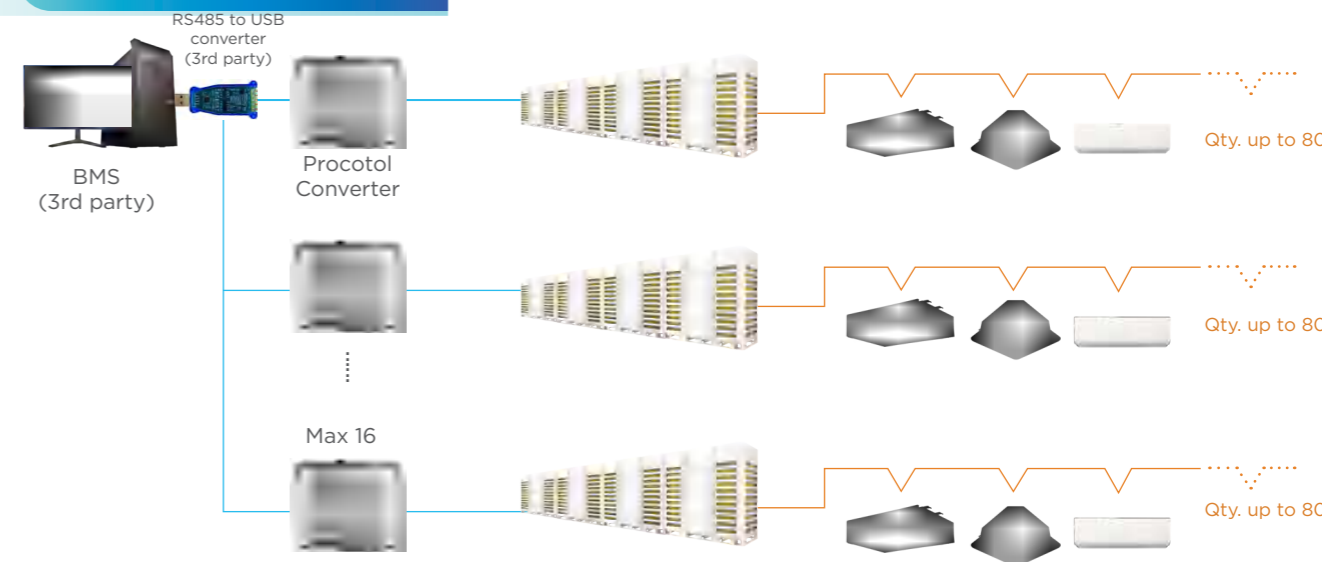



STABLE AND RELIABLE PERFORMANCE

ZERO has always insisted on making high-quality products relying on advanced manufacturing equipments and deep technical accumulation. Excellent performance guarantees the stability operation.

ZERO VRF can make sure stable and high-efficient operation facing the complex and changeable working conditions.



Inverter module cooling protection technology



Six levels oil return technology



High precision refrigerant control technology



-25 °C ~ 56 °C
Ultra wide operating temperature range



Pressure self-regulating technology



Triple backup function



Rotation function



Multiple protections





4.06- Stage Oil Return Technology

- ZTVT is at the leading position on the oil separate, oil return, oil balance and storage technology. The oil system equipped with precise 6 grade management to make sure compressor safety, stability and reliability.

Multistage Oil Control Technology

- The VRF system have sufficient and balanced oil in working condition to ensure safety and avoid potential oil shortages.

- Level 1: Compressor internal oil separate
- Level 2: Compressor external oil separate
- Level 3: High-efficiency centrifugal oil separator
- Level 4: Oil balance pipes between compressors to ensure compressors running normally
- Level 5: Automatic oil balance system improves the compressor reliability
- Level 6: Smart oil return program to ensure the oil return completely

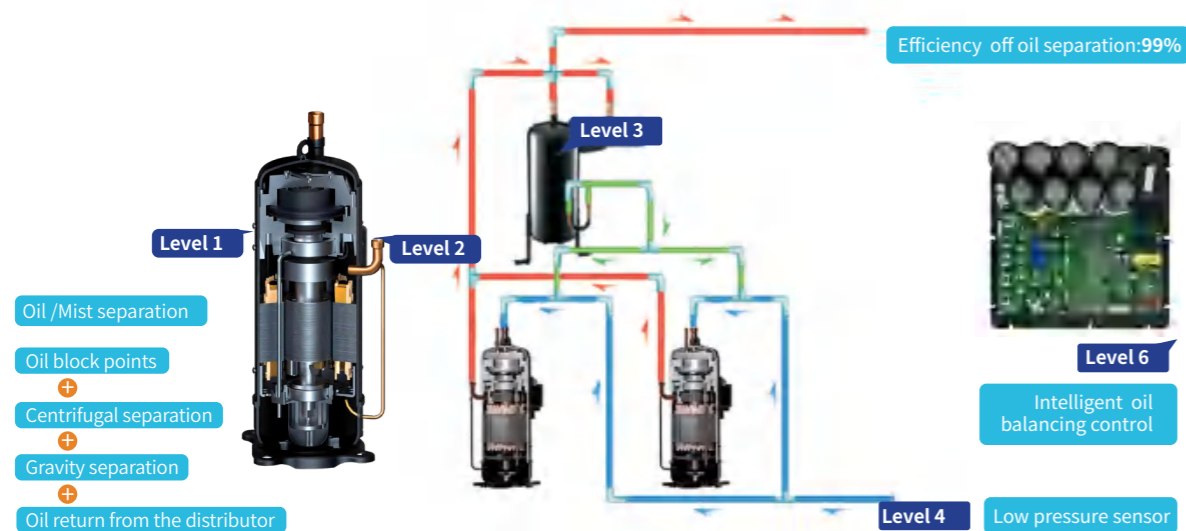

Automatic oil balancing

- Oil balancing system improves compressor oil storage and reliability, which also ensures the unit in good performance in cooling / heating mode.

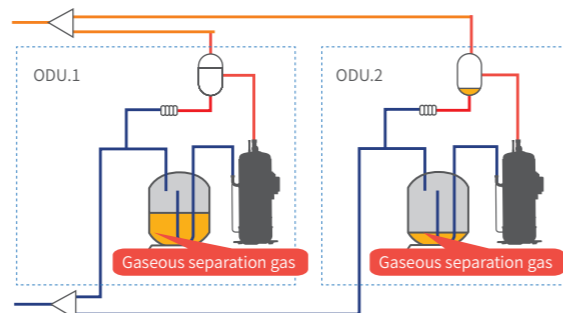

4.1 Inverter Module Cooling Protection

- When the outdoor units are running, high temperature will decrease the compressor frequency, reduce the cooling capacity, and shorten the life time. Traditional air-cooled method can make high thermal conductivity and worse heat dissipation performance, but ZERO module cooling technology can eliminate the heat of PCB, reduce the working temperature of inverter module and improve the PCB system reliability.

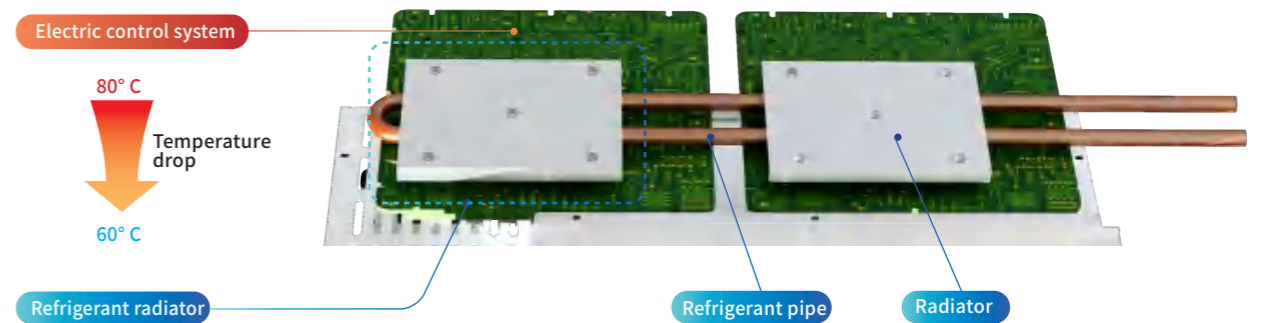

It can help take away the heat of the electric control box, improve the electrical component's reliability when working in a high-temperature environment, and ensure the system stable and safe.

Good structure design between radiator and refrigerant tube, help to reduce the heat resistance very well, to ensure better cooling for PCB.

4.2 High Precision Refrigerant Control Function

- The upgraded technology allows the system to manage the volume of refrigerant, and also reduce the refrigerant in entire system and increase efficiency.
- Liquid bypass control technology use multi-electronic expansion valve, it can adjust the refrigerant flow and control the overheating degree of the compressor, ensure the compressor to be highly efficient, safety and reliable.

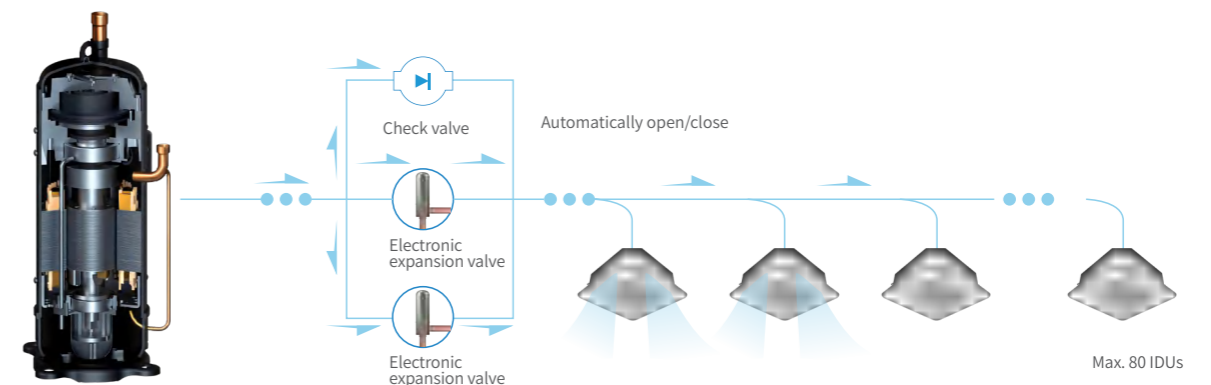

- Dual electronic expansion valve used for outdoor unit, adjust accuracy can reach 3000 level *, can adjust the refrigerant flow for the whole system.
- Silent electronic expansion valve used for indoor unit, precisely control refrigerant flow, improve the comfort and reliability.

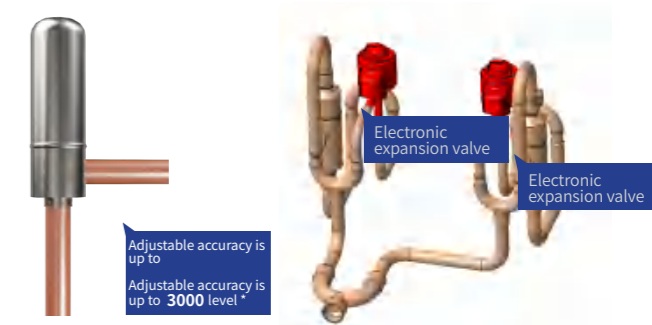

* Note: General adjustment is 480 level, can be customized to 3000 level adjustment

4.3 Wide Voltage Range

- The unit can operate in the range of voltage 290V~460V (International standard voltage 380V±10%), satisfy all kinds of voltage conditions.

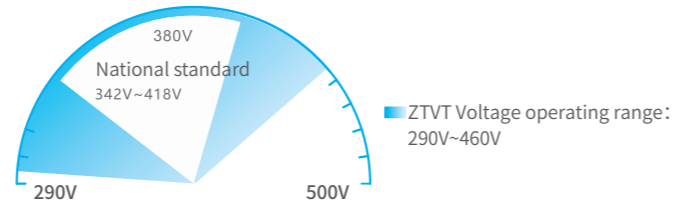

4.4 Wide Operation Temperature Range -25°C ~56°C

- Wide operation range, cooling: -5°C ~56°C, heating: -25°C ~28°C.

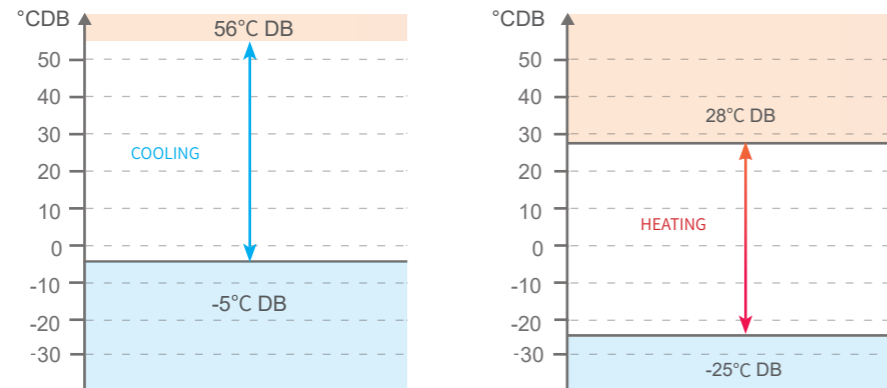

4.5 Pressure Self-adjustment Technology

- Pressure sensor is used to check system pressure, and adjust compressor operation frequency, fan speed, electronic expansion valve, to ensure the system with the best performance

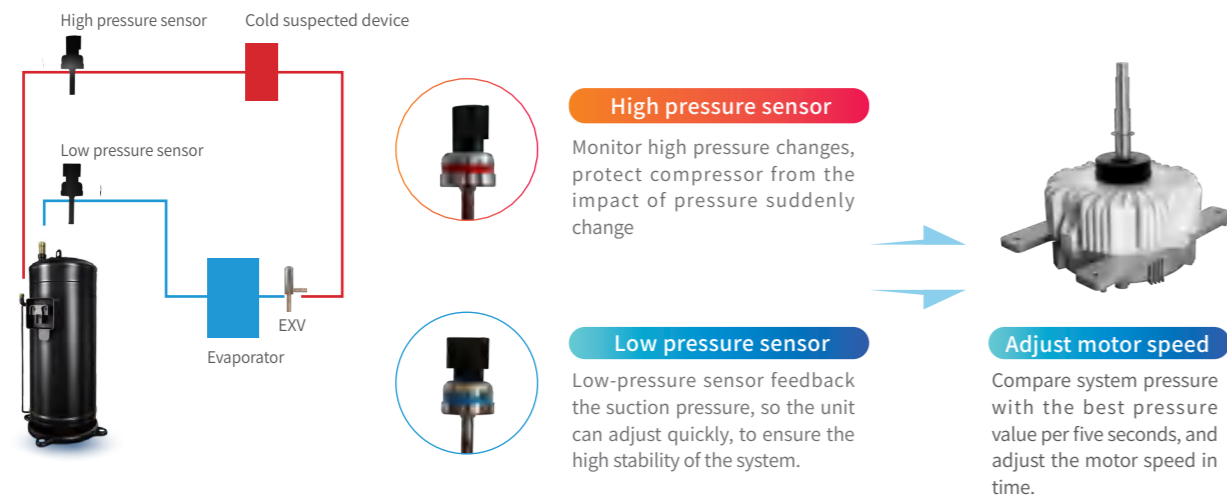

4.6 Triple Back-up Operation Technology

Compressor backup operation

- In units with two compressors, if one compressor fails, the other compressor can run on its own, to ensure the air conditioning system can work stably.

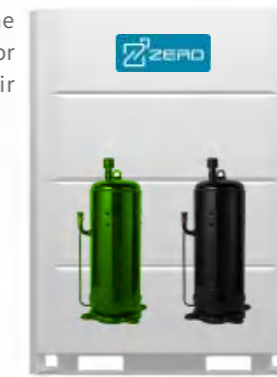
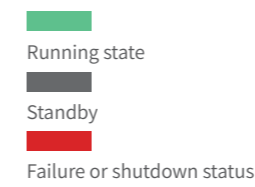

Running state



Emergency operation

Emergency operation of fan motor

- Some outdoor units are designed with dual fan, if the one fan motor fails, the other motor also can work normally, to avoid impact consumer's work and life.

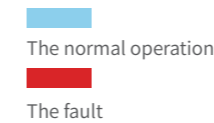

The normal operation



Emergency

ODU backup operation

- In a multi-unit system, if one outdoor unit fails, the other modules provide backup so that the system can continue operating.

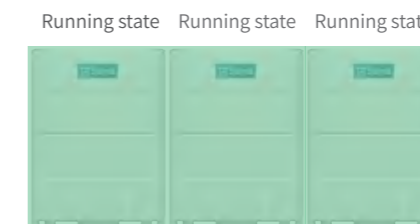

Running state

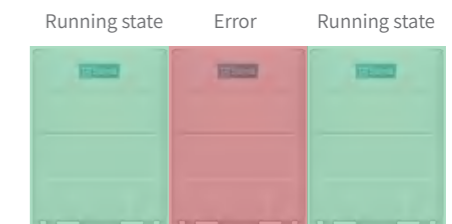

Emergency operation

4.7 Rotation Operation Technology

- If the system is connected to multiple modules, in order to ensure the balance of compressor operation, the automatic control of the microprocessor on the host can realize the automatic rotation operation function between the modules, effectively extend the service life of the unit.



4.8 Multiple Protection Functions

- Multiple protection functions to ensure the safe operation of the system.



Anti-adversity function

- The external force blows the outdoor unit fan to rotate in reverse. At this time, start and stop the rotation of the fan, and then restart the fan motor in a forward rotation according to the normal procedure, so as not to damage the fan motors due to excessive starting current.

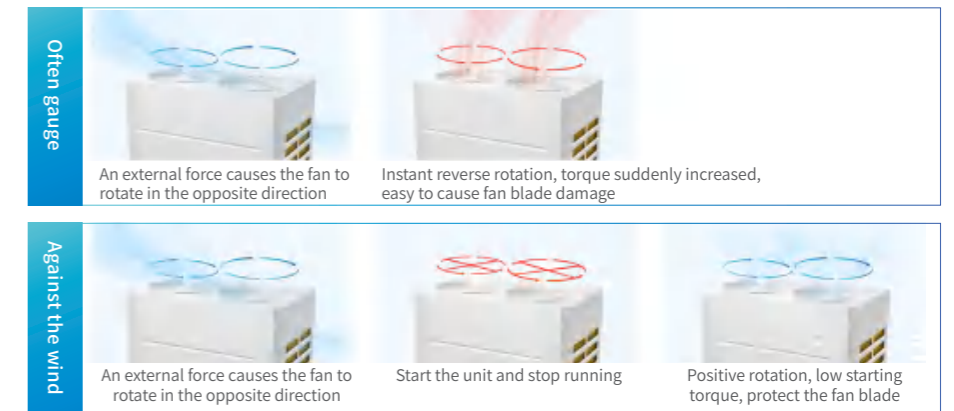

Phase sequence protection

- When the power cord of the outdoor unit is connected incorrectly, the circuit will start self-protection to avoid impact and damage to the main control board, inverter module and compressor. Ensure the normal operation of the air conditioner, without accidental electrical damage, fire, etc.

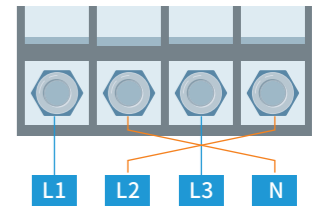

Low voltage recognition function

- Automatically recognize the working voltage, when the voltage is too low, give an early warning in time, and control the power consumption and capacity output of the multi-line system through the corresponding limit frequency.

Lightning protection

- The outdoor unit has a built-in anti-seismic module, which has anti-seismic and anti-interference functions to ensure the safe and stable operation of the system in bad weather.



Compressor overload protection

- When the compressor casing or motor temperature is too high, the circuit will automatically cut off to prevent the compressor from overloading and cause electrical damage, fire, etc.



Motor overheating protection

- When the current exceeds the set value, the temperature will rise, and the motor will be cut off in time during overcurrent operation to protect the motor from burning due to overload.





4.9 Anticorrosion Design

Hydrophilic aluminum fin

- It adopts anti-corrosion and anti-oxidation hydrophilic aluminum foil heat exchange fins, which have multiple protections of lubricating coating, hydrophilic coating and corrosion-resistant coating.



■ Lubrication layer ■ Hydrophilic coating ■ Corrosion resistant coating

Special corrosion-resistant coil

- Use special anti-corrosion coils. The base layer of ordinary galvanized sheet is increased with electrophoretic layer to achieve anti-corrosion effect. The coil fixing screws are stainless steel screws.



Electric control anti-corrosion

- The main board is equipped with moisture-proof glue, the sheet metal surface of the electric control box is treated with anti-corrosion spray, and the top of the metal casing fan capacitor is sprayed with anti-corrosion paint separately.

Pressure vessel

- It adopts surface phosphating treatment with good anti-corrosion performance.

Thick sheet metal design

- The surface of the sheet metal parts is phosphated and coated with special anti-corrosion materials. It improves the salt spray resistance and heat and humidity resistance, and greatly improves the anti-corrosion ability of the sheet metal.

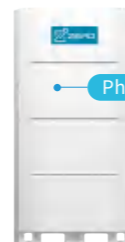

Phosphating



Motor protection upgrade

- Improve the protection level of the motor. The motor shaft is made of stainless steel. During the installation process, the motor shaft, nuts, gaskets and exposed motor shaft are coated with anti-rust grease, and the motor body screws and top cover screws are coated with silicone grease.

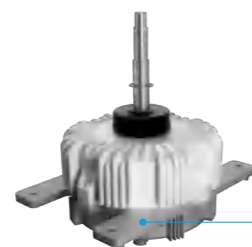

Silicon grease

Fastener

- The nails, nuts and washers are made of stainless steel or high anti-corrosion materials, and the screw heads inside the machine and outside the electric control box are coated with silicone grease for anti-corrosion.

Copper pipe weld

- Anticorrosive paint is sprayed on the welded joints of copper pipes.

5.0 Electronic Control Board SMT Placement Technology

- The electronic control main board adopts SMT patch sealing technology to improve the anti-clutter interference, to ensure that the main board is not affected by wind, sand, high temperature and high humidity, and to make the main control board longer.

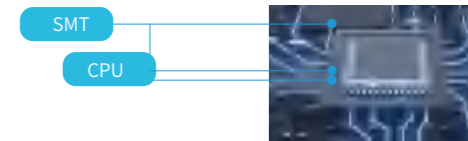

5.1 Anti-snow function

- In the snowy weather conditions in winter, in order to prevent the snow from adversely affecting the top of the outdoor unit fan, you can turn on anti-snow mode, the fan starts running to clear the snow to ensure the normal operation of the unit.

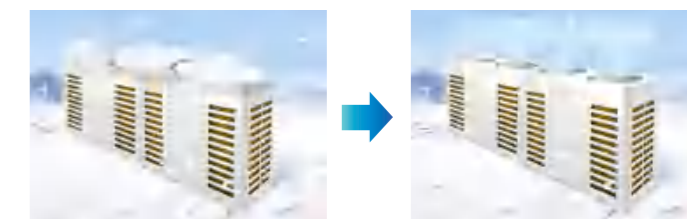

5.2 High-altitude Adaptive Technology *

- In high-altitude areas where the air is thin, the unit is prone to insufficient capacity. The ZTVT+ outdoor unit can automatically recognize the altitude position. When the altitude is too high and the capacity is insufficient, the high altitude adaptive mode will be activated for automatic compensation, which will greatly increase the fan speed and increase the air volume.

*Optional WIFI module required

5.3 Fault self-check

- ZTVT+ series DC inverter intelligent multi-connected central air-conditioners are equipped with electronic control fault self-diagnosis function, which can accurately locate the faulty parts and display the fault code when a fault occurs, thus improving the maintenance efficiency.

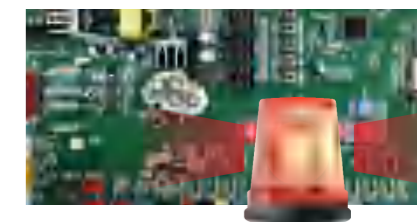



CONVENIENT INSTALLATION AND MAINTENANCE

For different application scenarios, different installation environments should be taken into consideration. The ZTVT takes every detail into consideration, in the product appearance design and function, which greatly improves the convenience of installation, speeds up the installation speed, and also improves the convenience of maintenance.



15 basic modules, satisfy all kind of requirement



Big-capacity module design, easy installation and space saving

1100

Super long refrigerant pipeline design, flexible structure

AUTO

Auto-refrigerant detecting and autocharging function



Max 130Pa high static pressure for outdoor unit (optional)



Convenient for the transportation, installation and commissioning



Auto-addressing function



ODU without oil balance pipe, compact design



Emergency power-off function for indoor unit maintenance



Commissioning software





5.6 Intelligent Multi-connection, Easy To Cope With The Spatial Layout

In order to meet the needs of different building types for air conditioning equipment, 15 basic outdoor unit modules are provided. The modules of 8-36HP can be combined freely, and the maximum combination can reach 144HP. There are 9 categories of indoor units, with more than 100 models to choose. The maximum internal unit capacity is 56kW. Outdoor units and indoor units can be freely matched and multi-connected. A system can connect up to 80 indoor units to meet the needs of different buildings.

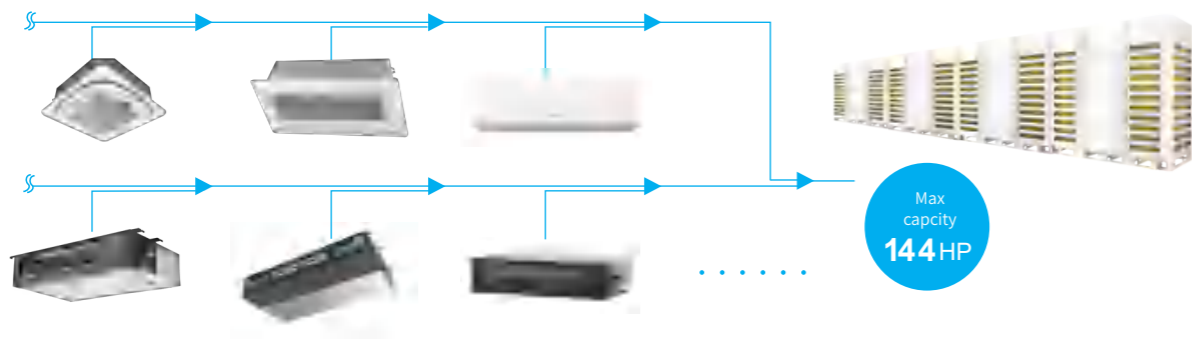

5.7 Large-capacity Module Design, Convenient Installation And Space Saving

- The maximum capacity of a single machine is 36HP.
- Smaller body size saves installation space.
- Reduce the workload of wiring, save labor cost and construction period.
- Less installation materials, saving purchase costs.

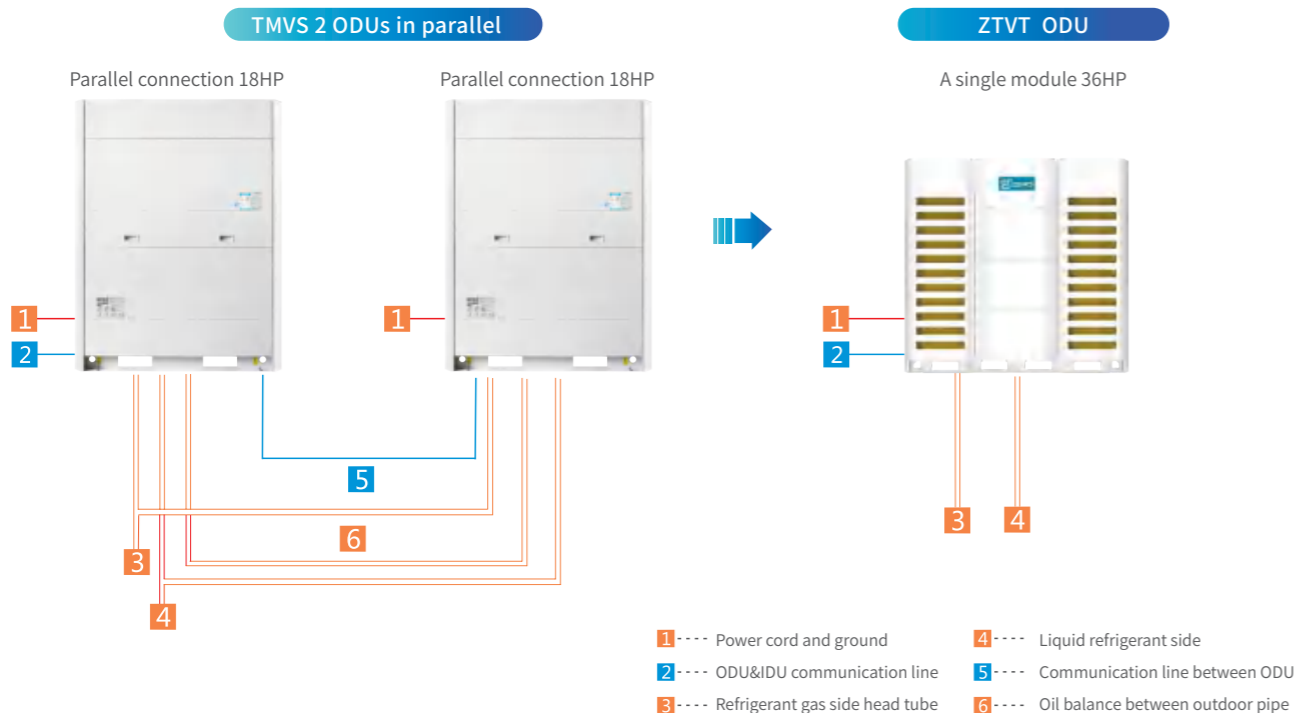

5.8 1100m Super Long Piping Design

- The industry-leading piping length, with a total length of 1100m, makes floor design more flexible.
- The max distance between the IDU and the ODU (the higher ODU) is 100m.
The max distance between the IDU and the ODU (the lower ODU) is 110m.
- The maximum distance between indoor units is 40m.
- The maximum actual single pipe length is 220m.
The maximum equivalent single tube length is 240m.
- The equivalent length from first indoor distributor to last indoor unit 120m.

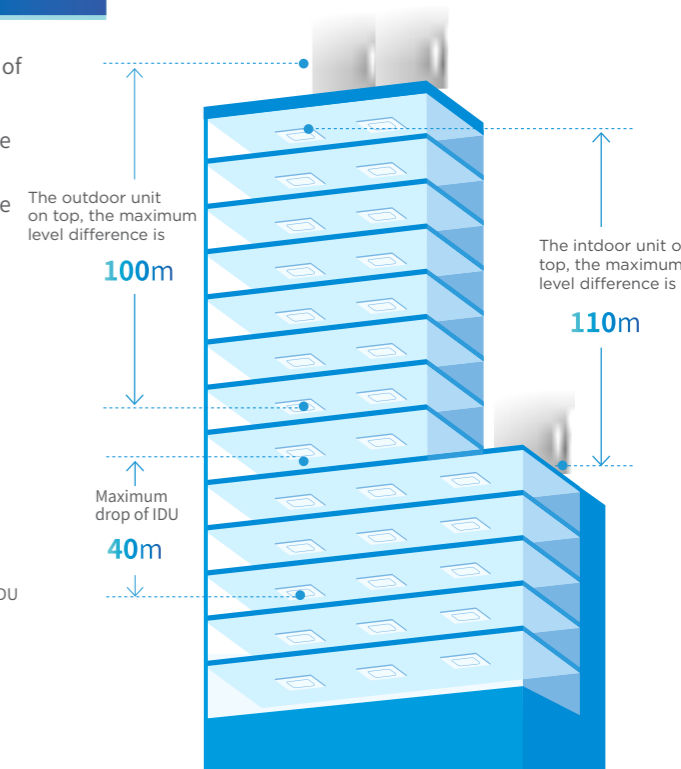
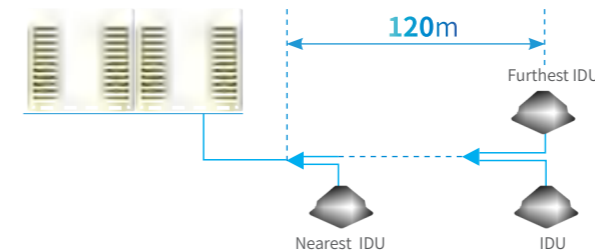

5.9 Single System Can Connect 80 IDUs

- ZTVT adopts the international advanced CAN bus communication technology, and one system can connect up to 80 indoor units, ensure stable and reliable in operation, realizes a large-capacity configuration of a single system, and is more flexible in engineering applications.

6.0 130Pa External Static Pressure *

- Through the combined action of new fan blades and high-volume fans, the system achieves higher external static pressures of up to 130 Pa* to ensure heat dissipation in layered or centralized placement of outdoor units.

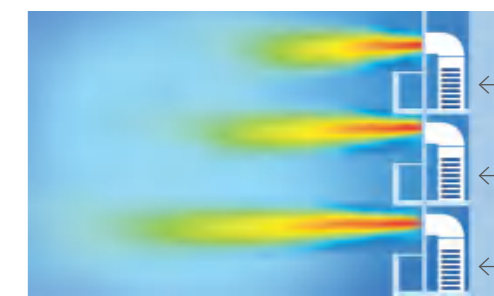
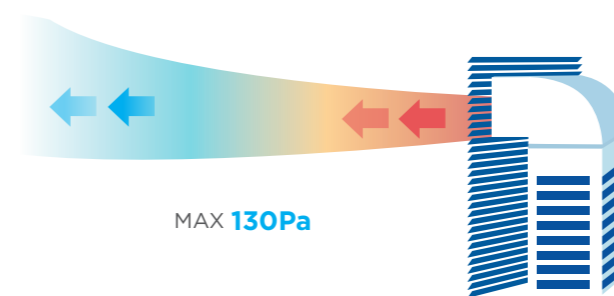

Better heat dissipation, better refrigeration effect

VRF static pressure contrast diagram

*Customizable to 130Pa, 80Pa for standard model



6.1 Automatic Refrigerant Judgment And Charging

Automatic refrigerant judgment

- When refrigerant is leaked and affecting the system operating, it will alert with error code, to avoid further impact to the system



Refrigerant recycle mode *

- While the system needs maintenance, refrigerant could be recycled and stored in ODU, by active this mode on PCB buttons, to avoid emission and pollution.

*Customized for local conditions

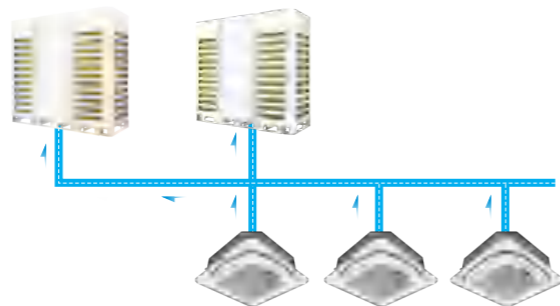

6.2 Compact Design And Convenient Transport

- The outdoor unit module has only 4 basic structures with the same height, which simplifies the design process and improves the flexibility of the system.



6.3 One-touch commissioning function

- You can choose to debug on the outdoor unit side or remotely through the monitoring software to realize the cooling and heating trial operation, no need opening the indoor units one by one, which is convenient for on-site debugging and improves the quality of construction at the project site.

6.4 Non-polarity Communication Connection

- CAN bus communication mode is applied between indoor and outdoor unit, no need to distinguish between positive and negative poles, and the installation is simpler and more efficient.

6.5 No Oil balance Pipe For ODU

- The outdoor units without oil equalizing pipe, which are more convenient for installation and also reduces the error of pipeline leakage.

- Liquid refrigerant tube
- Refrigerant trachea
- Equalizing tubing



6.6 360° pipe Connection Design

- These units allow the freedom to connect the piping in multiple directions, such as front side, left side, right side and back side, making installation easier.



6.7 Emergency Power-off Function For IDU Maintenance

- If an indoor unit needs to be powered off for maintenance due to failure, in order not to affect the operation of the entire system, the indoor unit can be powered off separately for maintenance, and other indoor units in the system can operate normally.

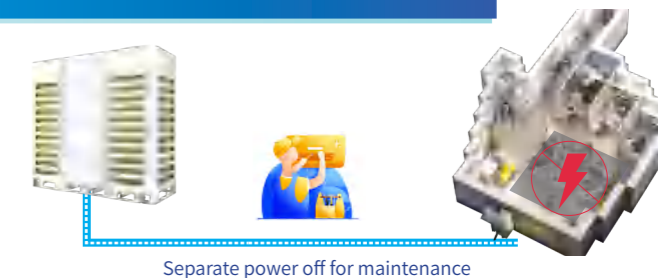

6.8 Commissioning Software

- The commissioning software is specially developed for ZERO air-conditioning system, which can carry out real-time status monitoring and loading control of the air-conditioning system.
- It can monitor the real-time operation parameters of 4 outdoor units and 80 indoor units in parallel system; And the operating parameters can be showed in Curve; It contains the function of saving the original data of operation, which is convenient for the R & D Engineers to remotely analyze the cause of failure; It also contains the forced load control function of the equipment, which is convenient for loading maintenance verification on the project site.

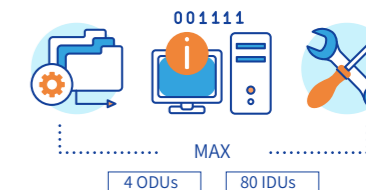

6.9 Auto-addressing Function

- The system can realize the automatic allocation of indoor unit address. There is no need to dial code during commissioning, which avoids the trouble of manual setting one by one. It is more intelligent and convenient.





ODU lineup



8 to 12 HP



14 to 24 HP



26-32 HP



34-36 HP

Note: 34HP/36HP are the models of enhanced vapor injection, which can enhance the heating performance under low ambient condition, others are regular models.

ODU Parameters(8-36HP)

Loading Capacity			8HP	10HP	12HP	14HP	16HP	18HP	20HP	22HP	
Model:CTVT-CHT**DX			252	280	335	400	450	504	560	615	
Cooling capacity	Capacity	Btu/h	86000	95500	114000	136000	153500	172000	191000	210000	
	Capacity	kW	25.2	28	33.5	40	45	50.4	56	61.5	
	Input	kW	5.38	6.78	8.09	10.20	12.07	13.48	15.67	17.67	
	Current	A	8.58	10.81	12.90	16.27	19.25	21.50	24.99	28.18	
Heating capacity	EER	W/W	4.68	4.13	4.14	3.92	3.73	3.74	3.57	3.48	
	Capacity	Btu/h	92000	107000	128000	153500	170600	191000	215000	235000	
	Capacity	kW	27	31.5	37.5	45	50	56	63	69	
	Input	kW	5.48	6.68	8.20	10.30	11.78	13.51	15.33	16.91	
Outdoor noise level(sound pressure level)	Current	A	8.74	10.65	13.08	16.43	18.79	21.55	24.45	26.97	
	COP	W/W	4.93	4.72	4.57	4.37	4.24	4.15	4.11	4.08	
Refrigerant type/Quantity	Type		R410A								
	Charged volume	kg	9	9	9	11	11	12	14	14	
Design pressure	MPa		4.3/1.5								
Power supply			380-415V 3N ~ 50/60Hz								
Voltage Range			340-460								
Max. Power			kW	11.30	12.43	13.73	16.25	18.40	21.39	23.70	26.07
Max. Current			A	20.00	22.00	24.30	28.80	32.60	37.90	42.00	46.20
Outdoor fan motor	Qty		1	1	1	1	1	1	2	2	
	Output	W	560	560	560	920	920	920	560*2	560*2	
	Air volume	m ³ /h	11000	11000	11500	13500	14000	15500	19000	19000	
Connecting Pipe	Gas	mm	φ25.4	φ25.4	φ25.4	φ28.6	φ28.6	φ28.6	φ28.6	φ28.6	
	Liquid	mm	φ12.7	φ12.7	φ12.7	φ12.7	φ12.7	φ12.7	φ15.88	φ15.88	
Max. height drop (high head)			m 110(100)								
Max. length of connecting indoor unit			m 220								
Max. length of connecting pipe			m 1100								
Net dimensions(W x H x D)			mm 925×1780×845				mm 1340×1780×845				
Net weight			Outdoor	kg 215	kg 215	kg 215	kg 270	kg 270	kg 280	kg 315	kg 315
Packing dimensions(W x H x D)			mm 1000×1940×920				mm 1420×1940×920				
Gross weight			Outdoor	kg 225	kg 225	kg 225	kg 290	kg 290	kg 300	kg 335	kg 335
Cooling operating range			Outdoor side	°C -5-56							
Heating operating range			Outdoor side	°C -25-28							

Loading Capacity			24HP	26HP	28HP	30HP	32HP	34HP	36HP	
Model:CTVT-CHT**DX			680	730	785	850	900	950	1000	
Cooling capacity	Capacity	Btu/h	232000	250000	268000	290000	307000	324000	341200	
	Capacity	kW	68	73	78.5	85	90	95	100	
	Input	kW	18.46	18.50	20.55	22.76	24.53	25.68	27.68	
	Current	A	29.44	29.51	32.78	36.30	39.12	40.96	44.15	
Heating capacity	EER	W/W	3.68	3.95	3.82	3.73	3.67	3.70	3.61	
	Capacity	Btu/h	256000	278000	300000	324000	341200	362000	382000	
	Capacity	kW	75	81.5	87.5	95	100	106	112	
	Input	kW	17.58	19.18	20.77	22.88	23.79	25.30	27.20	
Outdoor noise level(sound pressure level)	Current	A	28.04	30.59	33.13	36.49	37.94	40.35	43.38	
	COP	W/W	4.27	4.25	4.21	4.15	4.20	4.19	4.12	
Refrigerant type/Quantity	Type		R410A							
	Charged volume	kg	15	18	18	23	23	28	28	
Design pressure	MPa		4.3/1.5							
Power supply			380-415V 3N ~ 50/60Hz							
Voltage Range			340-460							
Max. Power			kW	29.68	31.49	33.27	33.47	34.59	39.44	41.25
Max. Current			A	52.60	55.80	59.00	59.30	61.29	69.90	73.10
Outdoor fan motor	Qty		2	2	2	2	2	2	2	
	Output	W	560*2	920*2	920*2	920*2	920*2	920*2	920*2	
	Air volume	m ³ /h	20000	26000	26000	27000	27000	29000	29000	
Connecting Pipe	Gas	mm	φ28.6	φ31.8	φ31.8	φ31.8	φ31.8	34.9	34.9	
	Liquid	mm	φ15.88	19.05	19.05	19.05	19.05	19.05	19.05	
Max. height drop (high head)			m 1100(100)							
Max. length of connecting indoor unit			m 220							
Max. length of connecting pipe			m 1100							
Net dimensions(W x H x D)			mm 1340×1780×845		mm 1760×1780×845			mm 1900×1780×845		
Net weight			Outdoor	kg 330	kg 380	kg 380	kg 420	kg 420	kg 480	kg 480
Packing dimensions(W x H x D)			mm 1840×1940×920		mm 1840×1940×920			mm 2000×1980×950		
Gross weight			Outdoor	kg 350	kg 405	kg 405	kg 445	kg 445	kg 505	kg 505
Cooling operating range			Outdoor side	°C -5-56						
Heating operating range			Outdoor side	°C -25-28						

1. Specifications are based on the following conditions:

2. Cooling: Indoor temperature 27°C DB/19°C WB, and outdoor temperature 35°C DB/24°C WB.

3. Heating: Indoor temperature 20°C DB/15°C WB, and outdoor temperature 7°C DB/6°C WB.

4. Due to ongoing product development, specifications are subject to change without notice.



VRF Systems, Various Combinations

In response to the different needs of building types for air-conditioning equipment, ZERO provides four basic outdoor unit modules, which can be freely combined in 2HP increments, and the maximum combination can reach 144HP, which can meet the high level design capacity differentiation, installation and transportation requirements of large and medium-sized air-conditioning projects.

Recommended combination table

HP	Combination1 (Space saving)	Combination2 (High efficiency)	Connected indoor unit qty.	HP	Combination1 (Space saving)	Combination2 (High efficiency)	Connected indoor unit qty.
8	8	8	13	78	28+28+22	20+20+20+18	80
10	10	10	16	80	28+28+24	20+20+20+20	80
12	12	12	19	82	28+28+26	22+20+20+20	80
14	14	14	23	84	28+28+28	22+22+20+20	80
16	16	16	26	86	32+28+26	22+22+22+20	80
18	18	18	29	88	32+28+28	22+22+22+22	80
20	20	20	33	90	32+32+26		80
22	22	22	36	92	32+32+28		80
24	24	12+12	39	94	32+32+30		80
26	26	14+12	43	96	32+32+32		80
28	28	16+12	46	98	36+32+30		80
30	30	16+14	50	100	36+32+32		80
32	32	18+14	53	102	36+36+30		80
34	34	18+16	56	104	36+36+32		80
36	36	18+18	59	106	36+36+34		80
38	22+16	14+12+12	63	108	36+36+36		80
40	22+18	14+14+12	66	110	28+28+28+26		80
42	24+18	14+14+14	69	112	28+28+28+28		80
44	24+20	16+14+14	72	114	32+28+28+26		80
46	24+22	16+16+14	75	116	32+28+28+28		80
48	24+24	16+16+16	78	118	32+32+28+26		80
50	28+22	18+16+16	80	120	32+32+28+28		80
52	28+24	18+18+16	80	122	32+32+32+26		80
54	28+26	18+18+18	80	124	32+32+32+28		80
56	28+28	14+14+14+14	80	126	32+32+32+30		80
58	32+26	16+14+14+14	80	128	32+32+32+32		80
60	32+28	16+16+14+14	80	130	36+32+32+30		80
62	32+30	16+16+16+14	80	132	36+32+32+32		80
64	32+32	16+16+16+16	80	134	36+36+32+30		80
66	36+30	18+16+16+16	80	136	36+36+32+32		80
68	36+32	18+18+16+16	80	138	36+36+36+30		80
70	36+34	18+18+18+16	80	140	36+36+36+32		80
72	36+36	18+18+18+18	80	142	36+36+36+34		80
74	28+24+22	20+18+18+18	80	144	36+36+36+36		80
76	28+24+24	20+20+18+18	80				

Space Saving Combination

2 ODU's

HP		38	40	42	44	46	48	50	52	54	
Recommended combination		22+16	22+18	24+18	24+20	24+22	24+24	28+22	28+24	28+26	
Model:CTVT-CHT***DX		1065	1119	1184	1240	1295	1360	1400	1465	1515	
Nominal cooling*1	(kW)	106.5	111.9	118.4	124	129.5	136	140	146.5	151.5	
Nominal heating*2	(kW)	119	125	131	138	144	150	156.5	162.5	169	
Rated cooling power input	(kW)	29.74	31.15	31.94	34.13	36.13	36.92	38.22	39.01	39.05	
Rated heating power input	(kW)	28.69	30.42	31.09	32.91	34.49	35.16	37.68	38.35	39.95	
Power supply	/	380V ~ 3N 50Hz/60Hz									
Compressor type	-	DV Inverter Scroll									
Dimension (W×D×H)	(mm)	(1340×845×1780) ×2						1760×845×1780 +1340×845×1780		(1760×845×1780) ×2	
Motor	Type	DC Inverter									
	Air volume	m ³ /h	33000	34500	35500	39000	39000	40000	45000	46000	52000
	Drive type	Direct									
Net weight	kg	585	595	610	645	645	660	695	710	760	
Operation noise *3	dB(A)	64	65	65	65	65	66	66	66	66	
Min. Amps *4	A	46.2+32.6	46.2+37.9	52.6+37.9	52.6+42.0	52.6+46.2	52.6+52.6	59+46.2	59.0+52.6	59.0+55.8	
MFC *4	A	63+50	63+50	63+50	63+63	63+63	63+63	80+63	80+63	80+63	

HP		56	58	60	62	64	66	68	70	72	
Recommended combination		28+28	32+26	32+28	32+30	32+32	36+30	36+32	36+34	36+36	
Model:CTVT-CHT***DX		1570	1630	1685	1750	1800	1850	1900	1950	2000	
Nominal cooling*1	(kW)	157	163	168.5	175	180	185	190	195	200	
Nominal heating*2	(kW)	175	181.5	187.5	195	200	206	212	218	224	
Rated cooling power input	(kW)	41.10	43.03	45.08	47.29	49.06	50.44	52.21	53.36	55.36	
Rated heating power input	(kW)	41.54	42.97	44.56	46.67	47.58	50.08	50.99	52.50	54.40	
Power supply	/	380V ~ 3N 50Hz/60Hz									
Compressor type	-	DV Inverter Scroll									
Dimension (W×D×H)	(mm)	(1760×845×1780) ×2						1900×845×1780+ 1760×845×1780		(1900×845×1780) ×2	
Motor	Type	DC Inverter									
	Air volume	m ³ /h	52000	53000	53000	54000	54000	56000	56000	58000	58000
	Drive type	Direct									
Net weight	kg	760	800	800	840	840	900	900	960	960	
Operation noise *3	dB(A)	67	67	67	68	68	69	69	69	69	
Min. current *4	A	59.0+59.0	61.3+55.8	61.3+59.0	61.3+59.3	61.3+61.3	73.1+59.3	73.1+61.3	73.1+69.9	73.1+73.1	
MFC *4	A	80+80	80+63	80+80	80+80	80+80	100+80	100+80	100+80	100+100	

*1. Rated cooling capacity test conditions: indoor 27°C DB/19°C WB, outdoor 35°C DB/24°C WB

*2. Rated heating capacity test conditions: indoor 20°C DB/15°C WB, outdoor 7°C DB/6°C WB, The performance parameters of the equipment are supposed to change due to product improvements, please note it would be not notice for this. Please refer to the product nameplate for specific parameters

*3. The noise is in accordance with the value tested under GB/T 18837-2015

*4. The air switch is selected according to the maximum fuse current, the electrical wiring specification is selected according to the minimum wire current.



Space Saving Combination

3 ODUs

HP	74	76	78	80	82	84	86	88	90		
Recommended combination	28+24+22	28+24+24	28+28+22	28+28+24	28+28+26	28+28+28	32+28+26	32+28+28	32+32+26		
Model:CTVT-CHT***DX	2080	2145	2185	2250	2300	2355	2415	2470	2530		
Nominal cooling capacity *1	(kW) 208	214.5	218.5	225	230	235.5	241.5	247	253		
Nominal heating capacity *2	(kW) 231.5	237.5	244	250	256.5	262.5	269	275	281.5		
Reted cooling power input	(kW) 56.68	57.47	58.77	59.56	59.60	61.65	63.58	65.63	67.56		
Rated heating power input	(kW) 55.26	55.93	58.45	59.12	60.72	62.31	63.74	65.33	66.76		
Power supply	/	380V ~ 3N 50Hz/60Hz									
Compressor type	-	DC inverter Scroll									
Dimension (W×D×H)	(mm)	1760×845×1780+ (1340×845×1780)×2		(1760×845×1780)×2+ 1340×845×1780		(1760×845×1780)×3					
Motor	Type	DC Inverter									
	Air volume	m ³ /h	65000	66000	71000	72000	78000	78000	79000	79000	80000
	Drive type	Direct									
Net	kg	1025	1040	1075	1090	1140	1140	1180	1180	1220	
Operation level *3	dB(A)	68	68	68	68	68	68	69	69	69	
Min. current *4	A	59.0+52.6+46.2	59.0+52.6+52.6	59.0+59.0+46.2	59.0+59.0+52.6	59.0+59.0+55.8	59.0+59.0+59.0	61.3+59.0+55.8	61.3+59.0+59.0	61.3+61.3+55.8	
MFC *4	A	80+63+63	80+63+63	80+80+63	80+80+63	80+80+63	80+80+80	80+80+63	80+80+63	80+80+63	

HP	92	94	96	98	100	102	104	106	108		
Recommended combination	32+32+28	32+32+30	32+32+32	36+32+30	36+32+32	36+36+30	36+36+32	36+36+34	36+36+36		
Model:CTVT-CHT***DX	2585	2650	2700	2750	2800	2850	2900	2950	3000		
Nominal cooling *1	(kW) 258.5	265	270	275	280	285	290	295	300		
Nominal heating *2	(kW) 287.5	295	300	307	312	319	324	330	336		
Rated cooling power input	(kW) 69.61	71.82	73.59	74.97	76.74	78.12	79.89	81.04	83.04		
Rated heating power input	(kW) 68.35	70.46	71.37	73.87	74.78	77.28	78.19	79.70	81.60		
Power supply	/	380V ~ 3N 50Hz/60Hz									
Compressor type	-	DC inverter scroll									
Dimension (W×D×H)	(mm)	(1760×845×1780)×3			(1900×845×1780) +(1760×845×1780)×2	(1900×845×1780)×2 +(1760×845×1780)	(1900×845×1780)×3				
Motor	Type	DC inverter									
	Air volume	m ³ /h	80000	81000	81000	83000	83000	85000	85000	87000	87000
	Drive way	Direct									
Net weight	kg	1220	1260	1260	1320	1320	1380	1380	1440	1440	
Operation noise*3	dB(A)	69	69	70	70	70	71	71	71	71	
Min. current*4	A	61.3+61.3+59.0	61.3+61.3+59.3	61.3+61.3+61.3	73.1+61.3+59.3	73.1+61.3+61.3	73.1+73.1+59.3	73.1+73.1+61.3	73.1+73.1+69.9	73.1+73.1+73.1	
MFC *4	A	80+80+80	80+80+80	80+80+80	100+80+80	100+80+80	100+100+80	100+100+80	100+100+80	100+100+100	

*1. Rated cooling capacity test conditions: indoor 27°C DB/19°C WB, outdoor 35°C DB/24°C WB

*2. Rated heating capacity test conditions: indoor 20°C DB/15°C WB, outdoor 7°C DB/6°C WB, The performance parameters of the equipment are supposed to change due to product improvements. Please refer to the product nameplate for specific parameters

*3. The noise is in accordance with the value tested under GB/T 18837-2015

*4. The air switch is selected according to the maximum fuse current, the electrical wiring specification is selected according to the minimum wire current.

Space Saving Combination

4 ODUs

HP	110	112	114	116	118	120	122	124	126		
Recommended combination	28+28+28+26	28+28+28+28	32+28+28+26	32+28+28+28	32+32+28+26	32+32+28+28	32+32+32+26	32+32+32+28	32+32+32+30		
Model:CTVT-CHT***DX	3085	3140	3200	3255	3315	3370	3430	3485	3550		
Nominal cooling capacity *1	(kW) 308.5	314	320	325.5	331.5	337	343	348.5	355		
Nominal heating capacity *2	(kW) 344	350	356.5	362.5	369	375	381.5	387.5	395		
Reted cooling power input	(kW) 80.20	82.20	84.13	86.18	88.11	90.16	92.09	94.14	96.35		
Rated heating power input	(kW) 81.50	83.08	84.51	86.10	87.53	89.12	90.55	92.14	94.25		
Power supply	/	380V ~ 3N 50Hz/60Hz									
Compressor type	-	DC inverter Scroll									
Dimension (W×D×H)	(mm)	(1760×845×1780)×4									
Motor	Type	DC inverter									
	Air volume	m ³ /h	104000	104000	105000	105000	106000	106000	107000	107000	108000
	Drive type	Direct									
Net weight	kg	1520	1520	1560	1560	1600	1600	1640	1640	1680	
Operation noise*3	dB(A)	69	69	70	70	70	70	70	70	70	
Min. current*4	A	59.0+59.0+ 59.0+55.8	59.0+59.0+ 59.0+59.0	61.3+59.0+ 59.0+55.8	61.3+59.0+ 59.0+59.0	61.3+61.3+ 59.0+55.8	61.3+61.3+ 59.0+59.0	61.3+61.3+ 61.3+55.8	61.3+61.3+ 61.3+59.0	61.3+61.3+ 61.3+59.3	
MFC *4	A	80+80+ 80+63	80+80+ 80+80	80+80+ 80+63	80+80+ 80+80	80+80+ 80+80	80+80+ 80+80	80+80+ 80+80	80+80+ 80+80	80+80+ 80+80	

HP	128	130	132	134	136	138	140	142	144		
Recommended combination	32+32 +32+32	36+32 +32+30	36+32 +32+32	36+36 +32+30	36+36+ 32+32	36+36 +36+30	36+36 +36+32	36+36 +36+34	36+36+ 36+36		
Model:CTVT-CHT***DX	3600	3650	3700	3750	3800	3850	3900	3950	4000		
Nominal cooling*1	(kW) 360	365	370	375	380	385	390	395	400		
Nominal heating*2	(kW) 400	407	412	419	424	431	436	442	448		
Rated cooling power input	(kW) 98.12	99.50	101.27	102.65	104.42	105.80	107.57	108.72	110.72		
Rated heating power input	(kW) 95.16	97.66	98.57	101.07	101.98	104.48	105.39	106.90	108.80		
Power supply	/	380V ~ 3N 50Hz/60Hz									
Compressor type	-	DC inverter scroll									
Dimension (W×D×H)	(mm)	(1760×845 ×1780)×4	(1900×845×1780) +(1760×845×1780)×3	(1900×845×1780)×2 +(1760×845×1780)×2	(1900×845×1780)×3 +(1760×845×1780)	(1900×845×1780)×4					
Motor	Type	DC inverter									
	Air volume	m ³ /h	108000	110000	110000	112000	112000	114000	114000	116000	116000
	Drive type	Direct									
Net weight	kg	1680	1740	1740	1800	1800	1860	1860	1920	1920	
Operation noise*3	dB(A)	70	71	71	71	71	71	71	71	71	
Min. current*4	A	61.3+61.3+ 61.3+61.3	73.1+61.3+ 61.3+59.3	73.1+61.3+ 61.3+61.3	73.1+73.1+ 61.3+59.3	73.1+73.1+ 61.3+61.3	73.1+73.1+ 73.1+59.3	73.1+73.1+ 73.1+61.3	73.1+73.1+ 73.1+69.9	73.1+73.1+ 73.1+73.1	
MFC *4	A	80+80+ 80+80	100+80+ 80+80	100+80+ 80+80	100+100+ 80+80	100+100+ 80+80	100+100+ 100+80	100+100+ 100+80	100+100+ 100+80	100+100+ 100+100	

*1. Rated cooling capacity test conditions: indoor 27°C DB/19°C WB, outdoor 35°C DB/24°C WB

*2. Rated heating capacity test conditions: indoor 20°C DB/15°C WB, outdoor 7°C DB/6°C WB, The performance parameters of the equipment are supposed to change due to product improvements. Please refer to the product nameplate for specific parameters

*3. The noise is in accordance with the value tested under GB/T 18837-2015

*4. The air switch is selected according to the maximum fuse current, the electrical wiring specification is selected according to the minimum wire current.



High Efficiency Combination

2 ODUs

HP		24	26	28	30	32	34	36	
Recommended combination		12+12	14+12	16+12	16+14	18+14	18+16	18+18	
Model:CTVT-CHT***DX		670	735	785	850	904	954	1008	
Nominal cooling *1	(kW)	67	73.5	78.5	85	90.4	95.4	100.8	
Nominal heating *2	(kW)	75	82.5	87.5	95	101	106	112	
Rated cooling power input	(kW)	16.18	18.29	20.16	22.27	23.68	25.55	26.96	
Rated heating power input	(kW)	16.40	18.50	19.98	22.08	23.81	25.29	27.02	
Power supply	/	380V ~ 3N 50Hz/60Hz							
Compressor type	-	DC inverter Scroll							
Dimension (W×D×H)	(mm)	(925×845×1780) ×2	(1340×845×1780) + (925×845×1780)		(1340×845×1780) ×2				
Motor	Type	DC Inverter							
	Air volume	m ³ /h	23000	25000	25500	27500	29000	29500	31000
	Drive way		Direct						
Net weight	kg	430	485	485	540	550	550	560	
Operation noise *3	dB(A)	61	61	62	62	63	63	64	
Min. current *4	A	24.3+24.3	28.8+24.3	32.6+24.3	32.6+28.8	37.9+28.8	37.9+32.6	37.9+37.9	
MFC *4	A	32+32	40+32	50+32	50+40	50+40	50+50	50+50	

3 ODUs

HP		38	40	42	44	46	48	50	52	54	
Recommended combination		14+12+12	14+14+12	14+14+14	16+14+14	16+16+14	16+16+16	18+16+16	18+18+16	18+18+18	
Model:CTVT-CHT***DX		1070	1135	1200	1250	1300	1350	1404	1458	1512	
Nominal cooling *1	(kW)	107	113.5	120	125	130	135	140.4	145.8	151.2	
Nominal heating *2	(kW)	120	127.5	135	140	145	150	156	162	168	
Rated cooling power input	(kW)	26.38	28.49	30.60	32.47	34.34	36.21	37.62	39.03	40.44	
Rated heating power input	(kW)	26.70	28.80	30.90	32.38	33.86	35.34	37.07	38.80	40.53	
Power supply	/	380V ~ 3N 50Hz/60Hz									
Compressor type	-	DC inverter scroll									
Dimension (W×D×H)	(mm)	(1340×845×1780)+(925×845×1780) ×2	(1340×845×1780) ×2+(925×845×1780)	(1340×845×1780) ×3							
Motor	Type	DC inverter									
	Air volume	m ³ /h	36500	38500	40500	41000	41500	42000	43500	45000	46500
	Drive type		Direct								
Net weight	kg	700	755	810	810	810	810	820	830	840	
Operation noise *3	dB(A)	63	63	63	64	64	64	65	65	65	
Min. current*4	A	28.8+24.3+24.3	28.8+28.8+24.3	28.8+28.8+28.8	32.6+28.8+28.8	32.6+32.6+28.8	32.6+32.6+32.6	37.9+32.6+32.6	37.9+37.9+32.6	37.9+37.9+37.9	
MFC *4	A	40+32+32	40+40+32	40+40+40	50+40+40	50+50+40	50+50+50	50+50+50	50+50+50	50+50+50	

*1. Rated cooling capacity test conditions: indoor 27°C DB/19°C WB, outdoor 35°C DB/24°C WB

*2. Rated heating capacity test conditions: indoor 20°C DB/15°C WB, outdoor 7°C DB/6°C WB, The performance parameters of the equipment are supposed to change due to product improvements. Please refer to the product nameplate for specific parameters

*3. The noise is in accordance with the value tested under GB/T 18837-2015

*4. The air switch is selected according to the maximum fuse current, the electrical wiring specification is selected according to the minimum wire current.

High Efficiency Combination

4 ODUs

HP		56	58	60	62	64	66	68	70	72	
Recommended combination		14+14+14+14	16+14+14+14	16+16+14+14	16+16+16+14	16+16+16+16	18+16+16+16	18+18+16+16	18+18+18+16	18+18+18+18	
Model:CTVT-CHT***DX		1600	1650	1700	1750	1800	1854	1908	1962	2016	
Nominal cooling *1	(kW)	160	165	170	175	180	185.4	190.8	196.2	201.6	
Nominal heating capacity *2	(kW)	180	185	190	195	200	206	212	218	224	
Rated cooling power input	(kW)	40.80	42.67	44.54	46.41	48.28	49.69	51.10	52.51	53.92	
Rated heating power input	(kW)	41.20	42.68	44.16	45.64	47.12	48.85	50.58	52.31	54.04	
Power supply	/	380V ~ 3N 50Hz/60Hz									
Compressor type	-	DC inverter Scroll									
Dimension (W×D×H)	(mm)	(1340×845×1780) ×4									
Motor	Type	DC inverter									
	Air volume	m ³ /h	54000	54500	55000	55500	56000	57500	59000	60500	62000
	Driver type		Direct								
Net weight	kg	1080	1080	1080	1080	1080	1090	1100	1100	1120	
Operation noise *3	dB(A)	65	65	65	65	66	66	66	66	67	
Min. current*4	A	28.8+28.8+28.8+28.8	32.6+28.8+28.8+28.8	32.6+32.6+28.8+28.8	32.6+32.6+32.6+28.8	32.6+32.6+32.6+32.6	37.9+32.6+32.6+32.6	37.9+37.9+32.6+32.6	37.9+37.9+37.9+32.6	37.9+37.9+37.9+37.9	
MFC *4	A	40+40+40+40	50+40+40+40	50+50+40+40	50+50+50+40	50+50+50+50	50+50+50+50	50+50+50+50	50+50+50+50	50+50+50+50	

HP		74	76	78	80	82	84	86	88	
Recommended combination		20+18+18+18	20+20+18+18	20+20+20+18	20+20+20+20	22+20+20+20	22+22+20+20	22+22+22+20	22+22+22+22	
Model:CTVT-CHT***DX		2072	2128	2184	2240	2295	2350	2405	2460	
Nominal cooling *1	(kW)	207.2	212.8	218.4	224	229.5	235	240.5	246	
Nominal heating capacity *2	(kW)	231	238	245	252	258	264	270	276	
Rated cooling power input	(kW)	56.11	58.30	60.49	62.68	64.68	66.68	68.68	70.68	
Rated heating power input	(kW)	55.86	57.68	59.50	61.32	62.90	64.48	66.06	67.64	
Power supply	/	380V ~ 3N 50Hz/60Hz								
Compressor type	-	DC inverter Scroll								
Dimension (W×D×H)	(mm)	(1760×845×1780) ×4								
Motor	Type	DC inverter								
	Air volume	m ³ /h	65500	69000	72500	76000	76000	76000	76000	76000
	Drive type		Direct							
Net weight	kg	1155	1190	1225	1260	1260	1260	1260	1260	
Operation noise *3	dB(A)	67	67	67	67	67	67	67	68	
Min. current*4	A	42.0+37.9+37.9+37.9	42.0+42.0+37.9+37.9	42.0+42.0+42.0+37.9	42.0+42.0+42.0+42.0	46.2+42.0+42.0+42.0	46.2+46.2+42.0+42.0	46.2+46.2+46.2+42.0	46.2+46.2+46.2+46.2	
MFC *4	A	63+50+50+50	63+63+50+50	63+63+63+50	63+63+63+63	63+63+63+63	63+63+63+63	63+63+63+63	63+63+63+63	

*1: Cooling capacity test working condition: indoor temperature 27°C DB/19°C WB, outdoor temperature 35°C DB/24°C WB

*2: Heat production test conditions: indoor temperature 20°C DB/15°C WB, outdoor temperature 7°C DB/6°C WB

*3: Noise according to GB/T 18837-2015 test value

*4: Select air switch according to the maximum fuse current, select electrical wiring specifications according to the minimum line current. Unit performance parameters are subject to modification without notice. For details, see the product nameplate.



T3 ODU lineup



8 to 10 HP



12 to 18 HP



20 to 26 HP



28 to 30 HP

T3 ODU Parameters (8-30HP)

Loading Capacity		8HP	10HP	12HP	14HP	16HP	18HP	20HP	22HP	24HP	26HP	28HP	30HP	
Model:CTVT-CHT***DXT		252	280	335	400	450	504	560	615	680	730	785	850	
Cooling capacity (T1)	Capacity	Btu/h	86000	95000	114000	136000	154000	172000	191000	210000	232000	249000	268000	290000
	Capacity	kW	25.2	27.9	33.3	40.0	45.0	50.5	56.0	61.5	68.0	73.0	78.5	85.0
	Input	kW	5.30	6.05	7.50	9.20	10.60	12.15	13.85	15.50	17.70	19.20	20.90	22.90
	Current	A	8.09	9.23	11.44	14.04	16.17	18.54	21.13	23.65	27.00	29.29	31.88	34.94
	EER Btu/(W·h)		16.20	15.70	15.20	14.80	14.55	14.15	13.80	13.55	13.10	12.95	12.80	12.65
Cooling capacity (T3)	EER	W/W	4.76	4.61	4.44	4.35	4.25	4.16	4.04	3.97	3.84	3.80	3.76	3.71
	Capacity	Btu/h	79000	87000	105000	125000	136000	157000	174000	194000	210000	227000	244000	263000
	Capacity	kW	23.1	25.5	30.9	36.6	40.0	46.0	51.0	57.0	61.5	66.5	71.5	77.0
	Input	kW	6.80	7.60	9.25	11.05	12.80	14.49	16.11	17.93	19.65	21.37	23.09	25.05
	Current	A	10.37	11.59	14.11	16.86	19.53	22.10	24.58	27.35	29.97	32.59	35.22	38.21
Cooling capacity (T4)	EER	Btu/(W·h)	11.60	11.45	11.35	11.30	10.65	10.85	10.80	10.70	10.60	10.55	10.50	
	EER	W/W	3.40	3.36	3.34	3.31	3.13	3.18	3.17	3.18	3.13	3.11	3.10	3.07
	Capacity	Btu/h	76000	84000	102000	120000	133000	152000	169000	186000	203000	220000	237000	254000
	Capacity	kW	22.2	24.6	30.0	35.0	39.0	44.5	49.5	54.5	59.5	64.5	69.5	74.5
	Input	kW	6.69	7.48	9.10	10.87	12.60	14.26	15.95	17.64	19.33	21.02	22.72	24.41
Heating capacity (T1)	Current	A	10.21	11.41	13.89	16.59	19.21	21.75	24.33	26.91	29.49	32.07	34.65	37.24
	EER	W/W	3.32	3.29	3.30	3.22	3.10	3.12	3.11	3.09	3.08	3.07	3.06	3.05
	EER	kW/RT	1.06	1.07	1.07	1.09	1.14	1.13	1.13	1.14	1.14	1.15	1.15	1.15
	Capacity	Btu/h	92000	105000	128000	153000	171000	191000	215000	235000	256000	278000	299000	324000
	Capacity	kW	27.0	30.9	37.5	45.0	50.0	56.0	63.0	69.0	75.0	81.5	87.5	95.0
Outdoor noise level (sound pressure level)	Input	kW	5.35	5.98	7.40	9.25	10.96	12.48	14.10	15.72	17.34	18.95	20.57	22.19
	Current	A	8.16	9.12	11.29	14.11	16.72	19.04	21.51	23.98	26.45	28.92	31.39	33.85
	COP	W/W	5.04	5.17	5.07	4.87	4.56	4.49	4.47	4.39	4.33	4.30	4.25	4.28
	dB(A)		58	59	60	61	62	63	63	64	64	65	65	66
Refrigerant type/Quantity	Type		R410A											
	Charged volume	kg	11	11	12	12	14	14	18	18	23	23	28	28
Design pressure	MPa	4.3/1.5	4.3/1.5	4.3/1.5	4.3/1.5	4.3/1.5	4.3/1.5	4.3/1.5	4.3/1.5	4.3/1.5	4.3/1.5	4.3/1.5	4.3/1.5	
Power supply		380-415V 3N ~ 50/60Hz												
Max. Power	kW	11.30	12.43	13.73	16.25	18.40	21.39	23.70	26.07	29.68	31.49	33.27	33.47	
Max. Current	A	20.0	22.0	24.3	28.8	32.6	37.9	42.0	46.2	52.6	55.8	59.0	59.3	
Voltage Range	V	340-460	340-460	340-460	340-460	340-460	340-460	340-460	340-460	340-460	340-460	340-460	340-460	
Connecting Pipe	Liquid	mm	φ12.7	φ12.7	φ12.7	φ12.7	φ15.88	φ15.88	19.05	19.05	19.05	19.05	19.05	
	Gas	mm	φ25.4	φ25.4	φ28.6	φ28.6	φ28.6	φ28.6	φ31.8	φ31.8	φ31.8	φ31.8	34.9	
Max. height drop (high head)	m	110(100)												
Max. length of connecting indoor unit	m	220	220	220	220	220	220	220	220	220	220	220	220	
Max. length of connecting pipe	m	1100	1100	1100	1100	1100	1100	1100	1100	1100	1100	1100	1100	
Net dimensions(W x H x D)	mm	925×1780×845			1340×1780×845			1760×1780×845			1900×1780×845			
Net weight	Outdoor	kg	230	230	270	270	315	315	380	380	420	420	480	480
Packing dimensions(W x H x D)	mm	1000×1940×920			1420×1940×920			1840×1940×920			2000×1980×950			
Gross weight	Outdoor	kg	240	240	290	290	335	335	405	405	445	445	505	505
Cooling operating range	Outdoor side	°C	-5-56	-5-56	-5-56	-5-56	-5-56	-5-56	-5-56	-5-56	-5-56	-5-56	-5-56	
	Heating operating range	Outdoor side	°C	-25-28	-25-28	-25-28	-25-28	-25-28	-25-28	-25-28	-25-28	-25-28	-25-28	
motor	Qty		1	1	1	1	2	2	2	2	2	2	2	
Air volume	m ³ /h	11000	11000	14000	15500	19000	19000	26000	27000	27000	29000	29000	29000	

Note: Specifications are based on the following conditions:

- 1.Cooling: Indoor temperature 29°C DB/19°C WB, and outdoor temperature 46°C DB/24°C WB.
- 2.Heating: Indoor temperature 20°C DB/15°C WB, and outdoor temperature 7°C DB/6°C WB.
- 3.Equivalent piping length:5m; Level difference:0m; Voltage:230V.
- 4.Sound Level: Indoor unit sound pressure level, measured at a point 1.5m downward from the unit center.
- 5.Outdoor unit sound pressure level, measured at a point 1.0m in front of the unit.
- 6.Optional simple wired controller; Universal remote controller; auto-restart(optional); Timer:only one circle.
- 7.Due to ongoing product development, specifications are subject to change without notice.



VRF systems, Various combinations

In response to the different needs of building types for air-conditioning equipment, ZERO provides four basic outdoor unit modules, which can be freely combined in 2HP increments, and the maximum combination can reach 120HP, which can meet the high level design capacity differentiation, installation and transportation requirements of large and medium-sized air-conditioning projects.

Recommended combination table

HP	Combination1 (Space saving)	Combination2 (High efficiency)	Connected indoor unit qty.	HP	Combination1 (Space saving)	Combination2 (High efficiency)	Connected indoor unit qty.
8	8	8	13	62	18+22+22	16+16+16+14	80
10	10	10	16	64	20+22+22	16+16+16+16	80
12	12	12	19	66	22+22+22	18+16+16+16	80
14	14	14	23	68	24+22+22	18+18+16+16	80
16	16	16	26	70	26+22+22	18+18+18+16	80
18	18	18	29	72	26+20+20	18+18+18+18	80
20	20	20	33	74	22+26+26	20+18+18+18	80
22	22	22	36	76	24+26+26	20+20+18+18	80
24	24	12+12	39	78	26+26+26	20+20+20+18	80
26	26	14+12	43	80	28+26+26	20+20+20+20	80
28	28	16+12	46	82	30+26+26	22+20+20+20	80
30	30	16+14	50	84	30+30+24	22+22+20+20	80
32	18+14		53	86	30+30+26	22+22+22+20	80
34	18+16		56	88	30+30+28	22+22+22+22	80
36	18+18		59	90	30+30+30		80
38	18+20	14+12+12	63	92	22+22+24+24		80
40	22+18	14+14+12	66	94	22+24+24+24		80
42	20+22	14+14+14	69	96	24+24+24+24		80
44	22+22	16+14+14	72	98	26+24+24+24		80
46	24+22	16+16+14	78	100	26+26+24+24		80
48	22+26	16+16+16	80	102	26+26+26+24		80
50	24+26	18+16+16	80	104	26+26+26+26		80
52	26+26	18+18+16	80	106	28+26+26+26		80
54	28+26	18+18+18	80	108	28+28+26+26		80
56	26+30	14+14+14+14	80	110	28+28+28+26		80
58	28+30	16+14+14+14	80	112	28+28+28+28		80
60	30+30	16+16+14+14	80	114	30+28+28+28		80
				116	30+30+28+28		80
				118	30+30+30+28		80
				120	30+30+30+30		80

Space Saving Combination

2 ODUs

HP	32	34	36	38	40	42	44	46
Recommended combination	18+14	18+16	18+18	20+18	22+18	20+22	22+22	24+22
Model (CTVT-CHT***DXT)	904	954	1008	1065	1119	1184	1240	1295
Nominal cooling *1 (kW)	82	86	92	97	102.5	107.5	113	118
Nominal heating*2 (kW)	101	106	112	119	125	132	138	144
Rated cooling power input (kW)	23.85	27.29	28.98	30.60	32.42	29.98	35.86	37.58
Rated heating power input (kW)	21.73	23.44	24.96	26.58	28.20	29.82	31.44	33.06
Power supply	/ 380V ~ 3N 50Hz/60Hz							
Compressor type	- DV Inverter Scroll							
Dimension (W×D×H) (mm)	(1340×1780×845)×2			1760×1780×845+ 1340×1780×845		(1760×1780×845)×2		
Motor	Type	DC Inverter						
	Air volume m ³ /h	34500	38000	38000	45000	46000	53000	54000
	Drive type	Direct						
Net weight (kg)	585	730	730	695	695	760	760	800
Operation noise *3 (dB(A))	63	63	64	64	65	65	65	65
Min. Amps *4 (A)	37.9+28.8	37.9+32.6	37.9+37.9	42.0+37.9	46.2+37.9	42.0+46.2	46.2+46.2	52.6+46.2
MFC *4 (A)	63+50	63+63	63+63	63+63	80+63	63+80	80+80	80+80

HP	48	50	52	54	56	58	60
Recommended combination	22+26	24+26	26+26	28+26	26+30	30+28	30+30
Model (CTVT-CHT***DXT)	1360	1400	1465	1515	1570	1630	1685
Nominal cooling *1 (kW)	123	128	133	138	143.5	148.5	154
Nominal heating*2 (kW)	150.5	156.5	163	169	176.5	182.5	190
Rated cooling power input (kW)	39.30	41.05	42.74	44.46	46.42	48.14	50.10
Rated heating power input (kW)	34.67	36.29	37.90	39.52	41.14	42.76	44.38
Power supply	/ 380V ~ 3N 50Hz/60Hz						
Compressor type	- DV Inverter Scroll						
Dimension (W×D×H) (mm)	(1760×1780×845)×2			1900×1780×845+ 1760×1780×845		(1900×1780×845)×2	
Motor	Type	DC Inverter					
	Air volume m ³ /h	56000	56000	58000	58000	58000	58000
	Drive type	Direct					
Net weight (kg)	800	840	840	900	900	960	960
Operation noise *3 (dB(A))	66	66	66	66	67	67	67
Min. current *4 (A)	46.2+55.8	52.6+55.8	55.8+55.8	58.95+55.8	55.8+59.31	59.31+58.95	59.31+59.31
MFC *4 (A)	80+80	80+80	80+80	100+80	80+100	100+100	100+100

*1. Rated cooling capacity test conditions: indoor 29°C DB/19°C WB, outdoor 46°C DB/24°C WB

*2. Rated heating capacity test conditions: indoor 20°C DB/15°C WB, outdoor 7°C DB/6°C WB, The performance parameters of the equipment are supposed to change due to product improvements, please note it would be not notice for this. Please refer to the product nameplate for specific parameters

*3. The noise is in accordance with the value tested under GB/T 18837-2015

*4. The air switch is selected according to the maximum fuse current, the electrical wiring specification is selected according to the minimum wire current.



Space Saving Combination

3 ODUs

HP		62	64	66	68	70	72	74	
Recommended combination		18+22+22	20+22+22	22+22+22	24+22+22	26+22+22	26+26+20	22+26+26	
Model (CTVT-CHT***DXT)		1750	1800	1850	1900	1950	2000	2080	
Nominal cooling capacity *1	(kW)	159	164	169.5	174.5	179.5	184	189.5	
Nominal heating capacity *2	(kW)	194	201	207	213	219.5	226	232	
Rated cooling power input	(kW)	50.35	51.97	53.79	55.51	57.23	58.85	60.67	
Rated heating power input	(kW)	43.92	45.54	47.16	48.78	50.39	52.00	53.62	
Power supply	/	380V ~ 3N 50Hz/60Hz							
Compressor type	-	DC inverter Scroll							
Dimension (W×D×H)	(mm)	1340×1780×845+ (1760×1780×845)×2		(1760×1780×845)×3					
Motor	Type	DC Inverter							
	Air volume	m ³ /h	73000	80000	81000	81000	83000	84000	85000
	Drive type	Direct							
Net	kg	1075	1140	1140	1180	1180	1220	1220	
Operation level *3	dB(A)	67	67	67	67	68	68	68	
Min. current *4	A	37.9+46.2+46.2	42.0+46.2+46.2	46.2+46.2+46.2	52.6+46.2+46.2	55.8+46.2+46.2	55.8+55.8+42.0	46.2+55.8+55.8	
MFC *4	A	63+80+80	63+80+80	80+80+80	80+80+80	80+80+80	80+80+63	80+80+80	

HP		76	78	80	82	84	86	88	90
Recommended combination		24+26+26	26+26+26	28+26+26	30+26+26	30+30+24	30+28+28	30+30+28	30+30+30
Model (CTVT-CHT***DXT)		2145	2185	2250	2300	2355	2415	2470	2530
Nominal cooling *1	(kW)	194.5	199.5	204.5	210	215.5	220	225.5	231
Nominal heating *2	(kW)	238	244.5	250.5	258	265	270	277.5	285
Rated cooling power input	(kW)	62.39	64.11	65.83	67.79	69.75	71.23	73.19	75.15
Rated heating power input	(kW)	55.24	56.85	58.47	60.09	61.72	63.33	64.95	66.57
Power supply	/	380V ~ 3N 50Hz/60Hz							
Compressor type	-	DC inverter scroll							
Dimension (W×D×H)	(mm)	85000	87000	87000	87000	88000	89000	89000	89000
Motor	Type	DC inverter							
	Air volume	m ³ /h	(1760×1780×845)×3	1900×1780×845+ (1760×1780×845)×2		(1900×1780×845)×2 +1760×1780×845	(1900×1780×845)×3		
	Drive way	Direct							
Net weight	kg	1260	1260	1320	1320	1380	1440	1440	1440
Operation noise*3	dB(A)	68	68	68	69	69	69	69	69
Min. current*4	A	52.6+55.8+55.8	55.8+55.8+55.8	59.0+55.8+55.8	59.3+55.8+55.8	59.3+59.3+52.6	59.3+59.0+59.0	59.3+59.3+59.0	59.3+59.3+59.3
MFC *4	A	80+80+80	80+80+80	100+80+80	100+80+80	100+100+80	100+100+100	100+100+100	100+100+100

*1. Rated cooling capacity test conditions: indoor 29°C DB/19°C WB, outdoor 46°C DB/24°C WB

*2. Rated heating capacity test conditions: indoor 20 °C DB/15 °C WB, outdoor 7 °C DB/6 °C WB, The performance parameters of the equipment are supposed to change due to product improvements, please note it would be not notice for this. Please refer to the product nameplate for specific parameters

*3. The noise is in accordance with the value tested under GB/T 18837-2015

*4. The air switch is selected according to the maximum fuse current, the electrical wiring specification is selected according to the minimum wire current.

Space Saving Combination

4 ODUs

HP		92	94	96	98	100	102	104	106	
Recommended combination		22+22+24+24	22+24+24+24	24+24+24+24	26+24+24+24	26+26+24+24	26+26+26+24	26+26+26+26	28+26+26+26	
Model (CTVT-CHT***DXT)		2585	2650	2700	2750	2800	2850	2900	2950	
Nominal cooling capacity *1	(kW)	236	241	246	251	256	261	266	271	
Nominal heating capacity *2	(kW)	288	294	300	306.5	313	319.5	326	332	
Rated cooling power input	(kW)	75.16	76.88	78.60	80.32	82.04	83.76	85.48	87.20	
Rated heating power input	(kW)	66.12	67.74	69.36	70.97	72.58	74.19	75.80	77.42	
Power supply	/	380V ~ 3N 50Hz/60Hz								
Compressor type	-	DC inverter Scroll								
Dimension (W×D×H)	(mm)	(1760×1780×845)×4							1900×1780×845+ (1760×1780×845)×3	
Motor	Type	DC inverter								
	Air volume	m ³ /h	108000	108000	108000	110000	112000	114000	116000	116000
	Drive type	Direct								
Net weight	kg	1600	1640	1680	1680	1680	1680	1680	1740	
Operation noise*3	dB(A)	67	67	67	68	68	68	68	68	
Min. current*4	A	46.2+46.2 +52.6+52.6	46.2+52.6 +52.6+52.6	52.6+52.6 52.6+52.6	55.8+52.6 +52.6+52.6	55.8+55.8 +52.6+52.6	55.8+55.8 +55.8+52.6	55.8+55.8 +55.8+55.8	58.95+55.8 +55.8+55.8	
MFC *4	A	80+80+80+80	80+80+80+80	80+80+80+80	80+80+80+80	80+80+80+80	80+80+80+80	80+80+80+80	100+80+80+80	

HP		108	110	112	114	116	118	120	
Recommended combination		28+28+26+26	28+28+28+26	28+28+28+28	30+28+28+28	30+30+28+28	30+30+30+28	30+30+30+30	
Model (CTVT-CHT***DXT)		3000	3085	3140	3200	3255	3315	3370	
Nominal cooling*1	(kW)	276	281	286	291.5	297	302.5	308	
Nominal heating*2	(kW)	338	344	350	357.5	365	372.5	380	
Rated cooling power input	(kW)	88.92	90.64	92.36	94.32	96.28	98.24	100.2	
Rated heating power input	(kW)	79.04	80.66	82.28	83.90	85.52	87.14	88.76	
Power supply	/	380V ~ 3N 50Hz/60Hz							
Compressor type	-	DC inverter scroll							
Dimension (W×D×H)	(mm)	(1900×1780×845)×2+ (1760×1780×845)×2	(1900×1780×845)×3 +1760×1780×845	(1900×1780×845)×4					
Motor	Type	DC inverter							
	Air volume	m ³ /h	116000	116000	116000	119000	119000	119000	119000
	Drive type	Direct							
Net weight	kg	1800	1860	1920	1920	1920	1920	1920	
Operation noise*3	dB(A)	68	68	68	69	69	69	69	
Min. current*4	A	58.95+58.95 +55.8+55.8	58.95+58.95 +58.95+55.8	58.95+58.95 +58.95+58.95	59.31+58.95 +58.95+58.95	59.31+59.31 +58.95+58.95	59.31+59.31+ 59.31+58.95	59.31+59.31 +59.31+59.31	
MFC *4	A	100+100+80+80	100+100+100+80	100+100+100+100	100+100+100+100	100+100+100+100	100+100+100+100	100+100+100+100	

*1. Rated cooling capacity test conditions: indoor 29°C DB/19°C WB, outdoor 46°C DB/24°C WB

*2. Rated heating capacity test conditions: indoor 20 °C DB/15 °C WB, outdoor 7 °C DB/6 °C WB, The performance parameters of the equipment are supposed to change due to product improvements, please note it would be not notice for this. Please refer to the product nameplate for specific parameters

*3. The noise is in accordance with the value tested under GB/T 18837-2015

*4. The air switch is selected according to the maximum fuse current, the electrical wiring specification is selected according to the minimum wire current.



High Efficiency Combination

2 ODUs

HP		24	26	28	30	
Recommended combination		12+12	14+12	16+12	16+14	
Model (CTVT-CHT***DXT)		670	735	785	850	
Nominal cooling *1	(kW)	61.8	66.9	70.9	76	
Nominal heating *2	(kW)	75	82.5	87.5	95	
Rated cooling power input	(kW)	18.50	20.30	22.05	23.85	
Rated heating power input	(kW)	14.80	16.65	18.36	20.21	
Power supply	/	380V ~ 3N 50Hz/60Hz				
Compressor type	-	DC inverter Scroll				
Dimension (W×D×H)	(mm)	(1340×1780×845)×2				
Motor	Type	DC Inverter				
	Air volume	m ³ /h	28000	29500	33000	34500
	Drive way		Direct			
Net weight	kg	540	540	585	585	
Operation noise *3	dB(A)	61	61	62	62	
Min. current *4	A	24.3+24.3	28.8+24.3	32.6+24.3	32.6+28.8	
MFC *4	A	50+50	50+50	63+50	63+50	

3 ODUs

HP		38	40	42	44	46	48	50	52	54	
Recommended combination		14+12+12	14+14+12	14+14+14	16+14+14	16+16+14	16+16+16	18+16+16	18+18+16	18+18+18	
Model (CTVT-CHT***DXT)		1065	1119	1184	1240	1295	1360	1400	1465	1515	
Nominal cooling *1	(kW)	97.8	102.9	108	112	116	120	126	132	138	
Nominal heating *2	(kW)	120	127.5	135	140	145	150	156	162	168	
Rated cooling power input	(kW)	29.55	31.35	33.15	34.90	36.65	38.40	40.09	41.78	43.47	
Rated heating power input	(kW)	24.05	25.90	27.75	29.46	31.17	32.88	34.40	35.92	37.44	
Power supply	/	380V ~ 3N 50Hz/60Hz									
Compressor type	-	DC inverter scroll									
Dimension (W×D×H)	(mm)	(1340×1780×845)×3									
Motor	Type	DC inverter									
	Air volume	m ³ /h	43500	45000	46500	50000	53500	57000	57000	57000	57000
	Drive type		Direct								
Net weight	kg	810	810	810	855	900	945	945	945	945	
Operation noise *3	dB(A)	64	64	64	65	65	65	66	66	66	
Min. current*4	A	28.8+24.3+24.3	28.8+28.8+24.3	28.8+28.8+28.8	32.6+28.8+28.8	32.6+32.6+28.8	32.6+32.6+32.6	37.9+32.6+32.6	37.9+32.6+32.6	37.9+32.6+32.6	37.9+32.6+32.6
MFC *4	A	50+50+50	50+50+50	50+50+50	63+50+50	63+63+50	63+63+63	63+63+63	63+63+63	63+63+63	

*1. Rated cooling capacity test conditions: indoor 29°C DB/19°C WB, outdoor 46°C DB/24°C WB

*2. Rated heating capacity test conditions: indoor 20°C DB/15°C WB, outdoor 7°C DB/6°C WB, The performance parameters of the equipment are supposed to change due to product improvements. Please refer to the product nameplate for specific parameters

*3. The noise is in accordance with the value tested under GB/T 18837-2015

*4. The air switch is selected according to the maximum fuse current, the electrical wiring specification is selected according to the minimum wire current.

High Efficiency Combination

4 ODUs

HP		56	58	60	62	64	66	68	70	72	
Recommended combination		14+14+14+14	16+14+14+14	16+16+14+14	16+16+16+14	16+16+16+16	18+16+16+16	18+18+16+16	18+18+18+16	18+18+18+18	
Model (CTVT-CHT***DXT)		1600	1650	1700	1750	1800	1854	1908	1962	2016	
Nominal cooling capacity *1	(kW)	144	148	152	156	160	166	172	178	184	
Nominal heating capacity *2	(kW)	180	185	190	195	200	206	212	218	224	
Reted cooling power input	(kW)	44.20	45.95	47.70	49.45	51.20	52.89	54.58	56.27	57.96	
Rated heating power input	(kW)	37.00	38.71	40.42	42.13	43.84	45.36	46.88	48.40	49.92	
Power supply	/	380V~3N 50Hz/60Hz									
Compressor type	-	DCinverter Scroll									
Dimension (W×D×H)	(mm)	(1340×1780×845)×4									
Motor	Type	DCinverter									
	Air volume	m ³ /h	62000	65500	69000	72500	76000	76000	76000	76000	76000
	Drive type		Direct								
Net weight	kg	1080	1125	1170	1215	1260	1260	1260	1260	1260	
Operation noise*3	dB(A)	64	65	65	65	65	66	66	66	66	
Min. current*4	A	28.8+28.8+28.8+28.8	32.6+28.8+28.8+28.8	32.6+32.6+28.8+28.8	32.6+32.6+32.6+28.8	32.6+32.6+32.6+32.6	37.9+32.6+32.6+32.6	37.9+32.6+32.6+32.6	37.9+32.6+32.6+32.6	37.9+32.6+32.6+32.6	
MFC *4	A	50+50+50+50	63+50+50+50	63+63+50+50	63+63+63+50	63+63+63+63				63+63+63+63	

HP		74	76	78	80	82	84	86	88	
Recommended combination		20+18+18+18	20+20+18+18	20+20+20+18	20+20+20+20	22+20+20+20	22+22+20+20	22+22+22+20	22+22+22+22	
Model (CTVT-CHT***DXT)		2072	2128	2184	2240	2295	2350	2405	2460	
Nominal cooling *1	(kW)	189	194	199	204	209.5	215	220.5	226	
Nominal heating capacity *2	(kW)	231	238	245	252	258	264	270	276	
Reted cooling power input	(kW)	59.58	61.20	62.82	64.44	66.26	68.08	69.90	71.72	
Rated heating power input	(kW)	51.54	53.16	54.78	56.40	58.02	59.64	61.26	62.88	
Power supply	/	380V ~ 3N 50Hz/60Hz								
Compressor type	-	DC inverter Scroll								
Dimension (W×D×H)	(mm)	(1760×1780×845)+(1340×1780×845)×3	(1760×1780×845)×2+(1340×1780×845)×2	(1760×1780×845)×3+(1340×1780×845)	(1760×1780×845)×4					
Motor	Type	DC inverter								
	Air volume	m ³ /h	83000	90000	97000	104000	105000	106000	107000	108000
	Drive type		Direct							
Net weight	kg	1325	1390	1455	1520	1520	1520	1520	1520	
Operation noise *3	dB(A)	66	66	66	66	67	67	67	67	
Min. current*4	A	42.0+37.9+37.9+37.9	42.0+42.0+37.9+37.9	42.0+42.0+42.0+37.9	42.0+42.0+42.0+42.0	46.2+42.0+42.0+42.0	46.2+46.2+42.0+42.0	46.2+46.2+46.2+42.0	46.2+46.2+46.2+42.0	
MFC *4	A	63+63+63+63	63+63+63+63	63+63+63+63	63+63+63+63	80+63+63+63	80+80+63+63	80+80+80+63	80+80+80+63	

*1: Cooling capacity test working condition: indoor temperature 29°C DB/19°C WB, outdoor temperature 46°C DB/24°C WB

*2: Heat production test conditions: indoor temperature 20°C DB/15°C WB, outdoor temperature 7°C DB/6°C WB

*3: Noise according to GB/T 18837-2015 test value

*4: Select air switch according to the maximum fuse current, select electrical wiring specifications according to the minimum line current.

Unit performance parameters are subject to modification without notice. For details, see the product nameplate.

Mini VRF

Full DC Inverter MINI VRF Unit



Powerful



High Efficiency



Comfortable



Stable





7.2 Strong Power, Stable Operation

High efficiency full DC inverter and twin rotary compressor

- ZERO Mini VRF use full DC inverter twin rotary compressor, which has high- efficiency both for full load condition and partial load condition, also leads to low noise, stable and reliable operation.



High efficiency DC fan motor

- The stepless regulation of the fan motor can meet the actual requirement of the capacity output, efficiency of motor is increased up to be 45%, higher efficiency in low spec



Electrical control box refrigerant cooling technology

- The refrigerant cooling technology can cool the PCBs in high ambient temperature condition, which improves the reliability, efficiency and lifespan of the MINI VRF units.

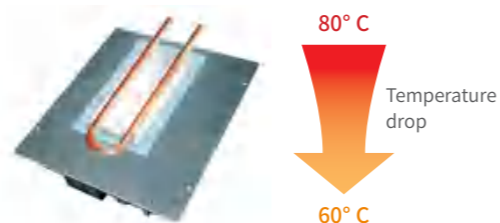

Wide operation temperature range

- The Mini VRF can operate under -20°C to ensure the heating demand, operate up to 54°C to make sure the cooling capacity output with high efficiency and stability.

7.3 Energy Saving And Environmental Friendly

R410A High-efficiency and environmentally friendly refrigerant

- R410A is an HFC refrigerant which does not damage the ozone layer. It is an energy efficient and environmentally friendly refrigerant.
- R410A is non-toxic and is a "non-flammable refrigerant". The composition structure of R410A is not easy to change and very stable.



RoHS Certification

- The ZERO mini VRF unit meets the RoHS environmental certification, which is environmental friendly.

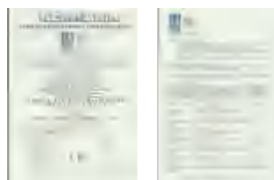

7.4 Beautiful Appearance, Upgraded Structure Design

Simple and elegant appearance

The top panel

No screw design to get high-quality structure and improve the strength, more beautiful

The front panel

Double 528mm wind wheel, larger air volume and lower noise.

Grille

Grille adopts DOE simulation design, air volume increased more than 7%

Footing

High strength foundation with rust - proof, corrosion - proof, more stable and reliable.

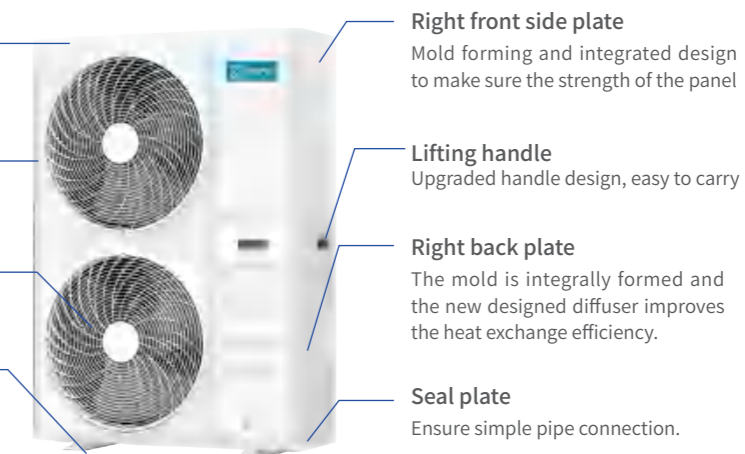

Three side direction pipe connection

- The front, side and back of the unit are designed with knock-out holes, coper pipes can be connected from various directions, which is more convenient to do the installation.

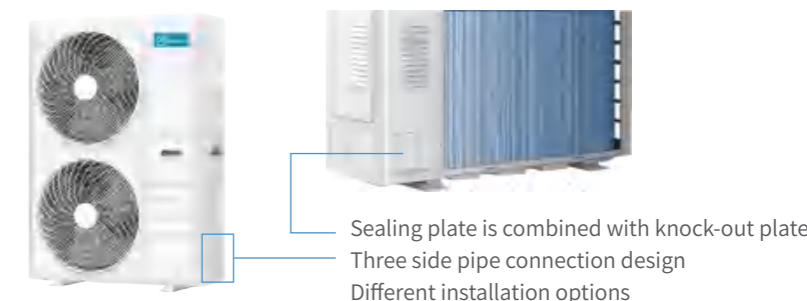



7.5 Mini VRF Parameters



10 -12kW



14 -16kW

Model			CTVT-CHS80BX	CTVT-CHS100BX	CTVT-CHS120BX	CTVT-CHS140BX	CTVT-CHS160BX	
Cooling capacity	Capacity	Btu/h	27000	34000	41000	49000	54000	
	Capacity	kW	8.0	10.0	12.0	14.5	16.0	
	Input	kW	2.55	2.75	3.05	4.10	4.80	
	Current	A	11.6	12.5	13.9	18.6	21.8	
	EER	Btu/(W·h)	10.6	12.4	13.4	12.0	11.3	
Heating capacity	EER	W/W	3.14	3.64	3.93	3.54	3.33	
	Capacity	Btu/h	34000	42000	48000	54000	61000	
	Capacity	kW	10.0	12.0	14.0	16.0	18.0	
	Input	kW	2.85	3.05	3.35	3.80	4.70	
	Current	A	13.0	13.9	15.3	17.3	21.4	
COP		W/W	3.51	3.93	4.18	4.21	3.83	
Outdoor noise level (sound power level)		dB(A)	54	55	56	56	56	
Refrigerant type/Quantity	Type		R410A	R410A	R410A	R410A	R410A	
	Charged volume	kg	2.3	2.3	2.3	3.7	3.7	
Design pressure		MPa	4.5/1.5	4.5/1.5	4.5/1.5	4.5/1.5	4.5/1.5	
Power supply			220-240V ~ 50/60Hz	220-240V ~ 50/60Hz	220-240V ~ 50/60Hz	220-240V ~ 50/60Hz	220-240V ~ 50/60Hz	
Voltage Range		V	198-264V	198-264V	198-264V	198-264V	198-264V	
Max. Power		kW	6.2	6.2	6.2	7.26	7.26	
Max. Current		A	28.2	28.2	28.2	33.0	33.0	
Fan	Qty.		1	1	1	1	1	
	Air volume	m ³ /h	4300	4300	4300	5300	5300	
Connecting Pipe	Liquid	mm	3/8"	3/8"	3/8"	3/8"	3/8"	
	Gas	mm	5/8"	5/8"	5/8"	5/8"	5/8"	
Max. height drop (high head)		m	20(20)	20(20)	20(20)	20(20)	20(20)	
Max. length of connecting indoor unit		m	50	50	50	50	50	
Max. length of connecting pipe		m	35	35	35	35	35	
Net dimensions (W x H x D)		Outdoor	mm	910 × 803 × 359	910 × 803 × 359	910 × 803 × 359	1010 × 850 × 410	1010 × 850 × 410
Net weight		Outdoor	kg	52	52	52	75	75
Packing dimensions (W x H x D)		Outdoor	mm	1022 × 835 × 480	1022 × 835 × 480	1022 × 835 × 480	1145 × 970 × 535	1145 × 970 × 535
Gross weight		Outdoor	kg	55	55	55	87	87
Cooling operating range	Outdoor side	°C	-5-56	-5-56	-5-56	-5-56	-5-56	
	Indoor side	°C	16-32	16-32	16-32	16-32	16-32	
Heating operating range	Outdoor side	°C	-25-28	-25-28	-25-28	-25-28	-25-28	
	Indoor side	°C	15-31	15-31	15-31	15-31	15-31	

Notes: 1. Specifications are based on the following conditions:
 2. Cooling: Indoor temperature 27°C DB/19°C WB, and outdoor temperature 35°C DB/24°C WB.
 3. Heating: Indoor temperature 20°C DB/15°C WB, and outdoor temperature 7°C DB/6°C WB.
 4. Equivalent piping length: 5m; Level difference: 0m; Voltage: 230V.

5. Sound Level: Indoor unit sound pressure level, measured at a point 1.5m downward from the unit center.
 6. Outdoor unit sound pressure level, measured at a point 1.0m in front of the unit.
 7. Optional simple wired controller; Universal remote controller; auto-restart (optional); Timer: only one circle.
 8. Due to ongoing product development, specifications are subject to change without notice.



12-18 KW



22.4-28 KW

Model			CTVT-CHS180BX	CTVT-CHS224DX	CTVT-CHS252DX	CTVT-CHS280DX
Cooling capacity	Capacity	Btu/h(W)	61400(18000)	76400 (22400)	86000 (25200)	95500 (28000)
	Input	W	5250	7200	8250	9100
	Current	A	24.2	11.5	13.2	14.6
	EER	W/W	3.43	3.11	3.05	3.08
Heating capacity	Capacity	Btu/h(W)	68240(20000)	83600 (24500)	92000 (27000)	105000 (30800)
	Input	W	5200	7100	8500	9500
	Current	A	23.5	11.4	13.6	15.2
	COP	W/W	3.85	3.45	3.18	3.24
Outdoor noise level (sound power level)		dB(A)	55	60	60	61
Refrigerant type/Quantity	Type		R410A	R410A	R410A	R410A
	Charged volume	kg	5.6	6.5	6.5	8.5
Design pressure		MPa	4.3/1.5	4.5/1.5	4.5/1.5	4.5/1.5
Power supply			220-240V~/50/60Hz	380V~3N/50Hz/60Hz		
Voltage Range		V	187-253	323-437	323-437	323-437
Max. Power		W	7200	11000	11500	12000
Max. Current		A	33	17.6	18.5	19.2
Connecting Pipe	Liquid	Inches	3/8"	3/8"	3/8"	3/8"
	Gas	Inches	3/4"	7/8"(22.2)	7/8"(22.2)	7/8"(22.2)
Max. height drop		m	30(20)	30(20)	30(20)	30(20)
Max. length of connecting pipe		m	120	120	120	120
Net dimensions		Outdoor (W x H x D)	mm	950 × 1560 × 400		
Net weight		Outdoor	kg	99	140	145
Packing dimensions		Outdoor (W x H x D)	mm	1080 × 1380 × 433		
Gross weight		Outdoor	kg	110	163	168

Notes: 1. Specifications are based on the following conditions:
 2. Cooling: Indoor temperature 27°C DB/19°C WB, and outdoor temperature 35°C DB/24°C WB.
 3. Heating: Indoor temperature 20°C DB/15°C WB, and outdoor temperature 7°C DB/6°C WB.
 4. Equivalent piping length: 5m; Level difference: 0m; Voltage: 230V.

5. Sound Level: Indoor unit sound pressure level, measured at a point 1.5m downward from the unit center.
 6. Outdoor unit sound pressure level, measured at a point 1.0m in front of the unit.
 7. Optional simple wired controller; Universal remote controller; auto-restart (optional); Timer: only one circle.
 8. Due to ongoing product development, specifications are subject to change without notice.

Mini VRF T3 Parameters



Loading Capacity			3.5HP	4HP	5HP	6HP	7HP	8HP
Model			CTVT-CHS100BXT	CTVT-CHS120BXT	CTVT-CHS140BXT	CTVT-CHS160BXT	CTVT-CHS18BXT	CTVT-CHS224BXT
Cooling capacity	Capacity	Btu/h	32400	36500	41000	46500	57000	66000
	Capacity	kW	9.3	10.5	12.0	13.5	16.5	19.2
	Input	kW	2.73	3.11	3.39	4.30	5.76	6.86
	EER	Btu/ (Wh)	11.85	11.70	12.10	10.80	9.90	9.60
	EER	W/W	3.41	3.37	3.54	3.14	2.87	2.80
Heating capacity	Capacity	Btu/h	40000	47000	54500	61500	68000	84000
	Capacity	kW	11.7	13.8	15.9	18.0	19.8	24.6
	Input	kW	2.64	3.13	3.63	4.24	4.82	6.05
	COP	W/W	4.43	4.42	4.39	4.25	4.11	4.07
Refrigerant type/ Quantity	Type		R410A	R410A	R410A	R410A	R410A	R410A
	Charged volume	kg	4	4	4.3	5.6	6.5	8.5
Design pressure	MPa		4.3/1.5	4.3/1.5	4.3/1.5	4.3/1.5	4.3/1.5	4.3/1.5
Voltage Range	V		220-240V ~ 50/60Hz				380-415V 3N ~ 50/60Hz	
Voltage Range	V		198-264V	198-264V	198-264V	198-264V	340-460	340-460
Max. Power	kW		6000	6000	6900	7200	11000	12000
Max. Current	A		27.8	27.8	31.4	33	17.6	19.2
Connecting Pipe	Liquid	mm	3/8"	3/8"	3/8"	3/8"	3/8"	3/8"
	Gas	mm	3/4"	3/4"	3/4"	3/4"	7/8"(22.2)	7/8"(22.2)
Max. height drop (high head)	m		30(20)	30(20)	30(20)	30(20)	30(20)	30(20)
Max. length of connecting indoor unit	m		120	120	120	120	120	120
Max. length of connecting pipe	m		70	70	70	70	70	70
Net dimensions	W x H x D	mm	950×1330×340				1120×1560×400	
Net weight	Outdoor	kg	91	91	94	99	130	140
Packing dimensions	W x H x D	mm	1080×1480×430				1250×1721×560	
Gross weight	Outdoor	kg	102	102	105	110	145	163
Cooling operating range	Outdoor side	°C	-5~56	-5~56	-5~56	-5~56	-5~56	-5~56
	Indoor side	°C	16~32	16~32	16~32	16~32	16~32	16~32
Heating operating range	Outdoor side	°C	-25~28	-25~28	-25~28	-25~28	-25~28	-25~28
	Indoor side	°C	15~31	15~31	15~31	15~31	15~31	15~31

Notes: 1. Specifications are based on the following conditions:
 2. Cooling: Indoor temperature 29°C DB/19°C WB, and outdoor temperature 46°C DB/24°C WB.
 3. Heating: Indoor temperature 20°C DB/15°C WB, and outdoor temperature 7°C DB/6°C WB.
 4. Equivalent piping length: 5m; Level difference: 0m; Voltage: 230V.

IDU lineup

Series	Type	Model	Capacity range(x100w)																							
			18	22	28	32	36	45	50	56	63	71	80	90	100	112	125	140	160	220	224	280	335	450	560	
360° air outlet cassette	Cooling & Heating	CTVT-ECFE**BX			●		●	●	●	●	●	●	●	●	●	●	●	●								
DC inverter duct	Cooling & Heating	CTVT-EDDL**BX	●	●	●	●	●	●	●	●	●	●	●	●	●	●	●	●								
High static pressure	Cooling & Heating	CTVT-EDH**BX										●			●	●		●		●	●	●				
Wall-mounted	Cooling & Heating	CTVT-EHW**BX		●	●			●	●	●		●	●	●												
Ceilinging & Floor	Cooling & Heating	CTVT-EFC**BX						●	●	●	●	●	●	●	●	●	●									
One-way cassette	Cooling & Heating	CTVT-ECS**BX	●	●	●		●	●	●	●																
Two-way cassette	Cooling & Heating	CTVT-ECD**BX		●	●		●	●	●	●	●	●														
Fresh air duct	Cooling & Heating	CTVT-EFA**BX															●		●		●	●				



360° Air-outlet Cassette

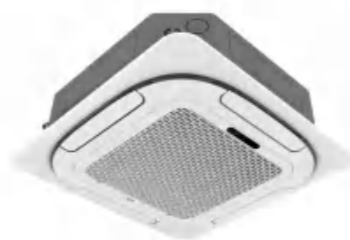

Recommended places
Office, restaurant, supermarket, shopping mall, lobby, etc

Technical characteristics



New panel design
Adopt the new design of "porcelain white" color, beautiful and generous, so that the indoor machine panel and the ceiling color more easily integrated, more noble, surround type air supply panel, air supply more comfortable.



360° wide-angle air supply
Comfortable air supply does not leave dead corner, every corner can enjoy cool; Uniform air supply, reduce the temperature difference, keep the indoor temperature comfortable; Air supply is no longer directed single, keep air circulation, air more fresh and healthy.



Large Air Outlet Volume
Through the new DC inverter fan motor, achieve 2100m³/h air outlet volume, and improve the air Exchange efficiency by 30%



50Pa Static Pressure Adjustment
Build-in 4 gear static pressure, 0~50Pa can be adjusted, to achieve the 4m long air outlet distance



7-level Fan Speed Volume
Thin fuselage, the installation space required is small, the unit can be easily installed in a fairly narrow ceiling.

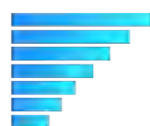

Standard condensate pump, easy to install
Equipped with advanced high-lift condensate drainage pump, the maximum head up to 1200mm, easy to install drainpipes.



Clean sterilization, healthy life
Standard health filter screen, effectively remove large particles in the air, optional silver ion purification module, adsorption of formaldehyde and odor, eliminate germs.



DC inverter fan motor technology
Adoption DC inverter motor technology, to improve the running efficiency by 15% and reduce the operation noise (min 31dB)



Ultra low noise
Using the advanced technology of three-dimensional spiral blade design, can reduce the air resistance, realize the machine low noise operation, "quiet" enjoy a comfortable life.



Standard float switch, timely warning
Standard float switch, when the condensate pump is faulty or the drainpipe is blocked, timely warning, prevent the water tray inside the machine overflow.

360° Air-outlet Cassette

Specification

Model		CTVT-ECFE28BX	CTVT-ECFE36BX	CTVT-ECFE45BX	CTVT-ECFE50BX	CTVT-ECFE56BX	CTVT-ECFE63BX	CTVT-ECFE71BX		
Control type		Remote Controller & Wired controller								
Cooling capacity	Capacity	W	2,800	3,600	4500	5000	5600	6300	7100	
	Input	W	20	20	25	25	25	35	35	
	Current	A	0.09	0.09	0.11	0.11	0.11	0.16	0.16	
Heating capacity	Capacity	W	3,200	4000	5000	5600	6300	7100	8000	
	Input	W	20	20	25	25	25	35	35	
	Current	A	0.09	0.09	0.11	0.11	0.11	0.16	0.16	
Indoor noise level at cooling (sound pressure level)		dB(A)	31	31	33	33	33	35	37	
Refrigerant type/Quantity		Type	R410A							
Design pressure		MPa	4.5	4.5	4.5	4.5	4.5	4.5	4.5	
Power supply			220-240V 50Hz							
Indoor air circulation (Cooling/Heating)	L/S		222	222	250	250	250	306	306	
	m ³ /h		800	800	900	900	900	1100	1100	
Indoor fan type			Centrifugal fan							
Connecting Pipe	Liquid	Inches	1/4"	1/4"	1/4"	1/4"	1/4"	3/8"	3/8"	
	Gas	Inches	1/2"	1/2"	1/2"	1/2"	1/2"	5/8"	5/8"	
Drainage Pipe		mm	25(ID21,OD25)							
Net dimensions(W x H x D)		mm	840*245*840							
Net weight		Indoor	kg	21.5	21.5	21.5	21.5	21.5	22	22
Packing dimensions (W x H x D)		mm	920*270*920							
Gross weight		Indoor	kg	25	25	25	25	25.5	25.5	
Loading Capacity			1.0HP	1.2HP	1.5HP	1.8HP	2.0HP	2.2HP	2.5HP	

Model		CTVT-ECFE80BX	CTVT-ECFE90BX	CTVT-ECFE100BX	CTVT-ECFE112BX	CTVT-ECFE125BX	CTVT-ECFE140BX	CTVT-ECFE160BX	
Control type		Remote Controller & Wired controller							
Cooling capacity	Capacity	W	8000	9000	10000	11200	12500	14000	16000
	Input	W	40	60	60	60	70	85	132
	Current	A	0.18	0.27	0.27	0.27	0.32	0.39	0.6
Heating capacity	Capacity	W	9000	10000	11200	12500	14000	16000	18000
	Input	W	40	60	60	60	70	85	132
	Current	A	0.18	0.27	0.27	0.27	0.32	0.39	0.6
Indoor noise level at cooling (sound pressure level)		dB(A)	38	39	40	41	43	43	47
Refrigerant type/Quantity		Type	R410A						
Design pressure		MPa	4.5	4.5	4.5	4.5	4.5	4.5	4.5
Power supply			220-240V 50Hz						
Indoor air circulation (Cooling/Heating)	L/S		361	417	444	444	500	500	583
	m ³ /h		1300	1500	1600	1600	1800	1800	2100
Indoor fan type			Centrifugal fan						
Connecting Pipe	Liquid	Inches	3/8"						
	Gas	Inches	5/8"						
Drainage Pipe		mm	25(ID21,OD25)						
Net dimensions(W x H x D)		mm	840*290*840						
Net weight		Indoor	kg	22	22.5	25	25	27.5	27.5
Packing dimensions (W x H x D)		mm	920*315*920						
Gross weight		Indoor	kg	25.5	26	28.5	28.5	31	31
Loading Capacity			3.0HP	3.2HP	3.6HP	4.0HP	4.5HP	5.0HP	6HP

Notes: 1. Specifications are based on the following conditions:
2. Cooling: Indoor temperature 27°C DB/19°C WB, and outdoor temperature 35°C DB/24°C WB.
3. Heating: Indoor temperature 20°C DB/15°C WB, and outdoor temperature 7°C DB/6°C WB.
4. Equivalent piping length: 5m; Level difference: 0m; Voltage: 230V.

5. Sound Level: Indoor unit sound pressure level, measured at a point 1.5m downward from the unit center.
6. Outdoor unit sound pressure level, measured at a point 1.0m in front of the unit.
7. Optional simple wired controller; Universal remote controller; auto-restart(optional); Timer: only one circle.
8. Due to ongoing product development, specifications are subject to change without notice.



DC Inverter Slim Duct



Recommended places

Office, conference room, hotel room, restaurant, living room, etc

Technical characteristics



Constant air volume

Fan motor automatically adjusts speed according to real-time wind resistance. To provide stable air volume to rooms.

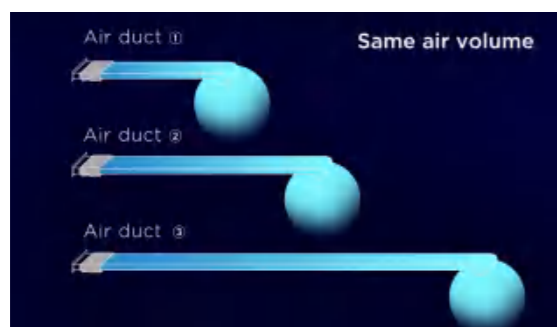

Ultra-thin body design, fashion and beautiful

The minimum height of the body is only 200mm, saving space. The drain pump can lift the condensing water up to 1200mm.



Health filter (optional)

The duct can be equipped with silver ion and activated carbon health filter.



High ESP

ESP up to 80Pa supports longer air duct and fits with more installation scenario.



Dc seven speed wind speed Energy-saving silent operation

DC motor, 7-speed air volume, energy-saving and silent operation. The lowest noise is 20 d B(A).



Standard float switch, timely warning

Standard float switch, when the condensate pump is faulty or the drainpipe is blocked, timely warning, prevent the water tray inside the machine overflow.



7-level Fan Speed Volume

Thin fuselage, the installation space required is small, the unit can be easily installed in a fairly narrow ceiling.

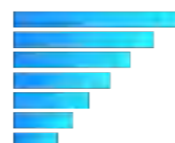

DC Inverter Slim Duct

Specification

Model	CTVT-EDDL18BX	CTVT-EDDL22BX	CTVT-EDDL28BX	CTVT-EDDL32BX	CTVT-EDDL36BX	CTVT-EDDL45BX	CTVT-EDDL50BX	CTVT-EDDL56BX	
Control type		Remote Controller & Wired controller							
Static pressure	Standard	20	20	20	20	20	20	20	
	Range	Pa	0 ~ 50	0 ~ 50	0 ~ 50	0 ~ 50	0 ~ 50	0 ~ 50	0 ~ 50
Cooling capacity	Capacity	W	1800	2200	2800	3200	3600	4500	5600
	Input	W	20	20	20	30	30	50	50
Heating capacity	Capacity	W	2200	2500	3200	3600	4000	5000	6300
	Input	W	20	20	20	30	30	50	50
Indoor noise level at cooling(sound pressure level)	High	dB(A)	0.09	0.09	0.09	0.14	0.14	0.23	0.23
	Med.	dB(A)	30	30	30	30	30	34	34
	Low	dB(A)	26	26	26	26	26	29	29
Refrigerant type/Quantity	Type	R410A							
Design pressure	MPa	4.5	4.5	4.5	4.5	4.5	4.5	4.5	
Power supply		220-240V~/50Hz							
Outlet size of indoor airflow	mm	510x140				730x140			
Returning vent size of indoor airflow	mm	570x172				790x172			
Indoor air circulation (Cooling/Heating)	L/S	139	139	139	153	153	236	236	236
	m ³ /h	500	500	500	550	550	850	850	850
Indoor fan type		Centrifugal fan							
Connecting Pipe	Liquid	Inches	1/4"	1/4"	1/4"	1/4"	1/4"	1/4"	1/4"
	Gas	Inches	3/8"	3/8"	3/8"	1/2"	1/2"	1/2"	1/2"
Drainage Pipe		mm 25(ID20,OD25)							
Net dimensions (W x H x D)	mm	700x200x450				920x200x450			
Net weight	Indoor	kg	15.5	15.5	15.5	15.5	18	18	18
Packing dimensions(W x H x D)	mm	900x250x555				1120x250x555			
Gross weight	Indoor	kg	18	18	18	18	21	21	21
Loading Capacity			0.6HP	0.8HP	1.0HP	1.1HP	1.2HP	1.5HP	2.0HP

Model	CTVT-EDDL63BX	CTVT-EDDL71BX	CTVT-EDDL80BX	CTVT-EDDL90BX	CTVT-EDDL100BX	CTVT-EDDL112BX	CTVT-EDDL125BX	CTVT-EDDL140BX	
Control type		Remote Controller & Wired controller							
Static pressure	Standard	20	20	20	60	60	60	60	
	Range	Pa	0 ~ 80	0 ~ 80	0 ~ 80	30 ~ 80	30 ~ 80	30 ~ 80	30 ~ 80
Cooling capacity	Capacity	W	6300	7100	8000	9000	10000	11200	12500
	Input	W	54	54	54	180	180	180	250
Heating capacity	Capacity	W	7100	8000	9000	10000	11200	12500	14000
	Input	W	54	54	54	180	180	180	250
Indoor noise level at cooling(sound pressure level)	High	dB(A)	0.25	0.25	0.25	0.9	0.9	0.9	1.2
	Med.	dB(A)	37	37	37	43	43	43	44
	Low	dB(A)	31	31	31	37	37	37	41
Refrigerant type/Quantity	Type	R410A							
Design pressure	MPa	4.5							
Power supply		220-240V~/50Hz							
Outlet size of indoor airflow	mm	930x140				1365x175			
Returning vent size of indoor airflow	mm	1004x165				1365x220			
Indoor air circulation (Cooling/Heating)	L/S	306				500		556	
	m ³ /h	1100				1800		2000	
Indoor fan type		Centrifugal fan							
Connecting Pipe	Liquid	Inches	3/8"						
	Gas	Inches	5/8"						
Drainage Pipe		mm 25(ID20,OD25)							
Net dimensions (W x H x D)	mm	1100x200x450				1400x250x700			
Net weight	Indoor	kg	22.5	22.5	22.5	36	36	36	38
Packing dimensions(W x H x D)	mm	1290x245x565				1632x298x827			
Gross weight	Indoor	kg	26	26	26	42	42	42	44
Loading Capacity			2.2HP	2.5HP	2.8HP	3.2HP	3.6HP	4HP	4.5HP

Notes: 1. Specifications are based on the following conditions:

- Cooling: Indoor temperature 27°C DB/19°C WB, and outdoor temperature 35°C DB/24°C WB.
- Heating: Indoor temperature 20°C DB/15°C WB, and outdoor temperature 7°C DB/6°C WB.
- Equivalent piping length: 5m; Level difference: 0m; Voltage: 230V.

5. Sound Level: Indoor unit sound pressure level, measured at a point 1.5m downward from the unit center.

- Outdoor unit sound pressure level, measured at a point 1.0m in front of the unit.
- Optional simple wired controller; Universal remote controller; auto-restart(optional); Timer: only one circle.
- Due to ongoing product development, specifications are subject to change without notice.



High Static Pressure Duct



Recommended places
Workshop, hotel, restaurant, shopping mall, ballroom, bar and other large space places

Technical characteristics



Healthy new wind, forest breathing
Easy introduction of outdoor fresh air heating refrigeration and indoor air exchange, keep indoor air fresh, bring you comfortable fresh air.



Ultra-thin body design, fashion and beautiful
The minimum thickness of the fuselage is only 380mm, which does not occupy indoor space.



Ultra-high static pressure design to meet various space requirements
Maximum static pressure 300Pa, can be long distance multi-point air supply, fully meet the air conditioning needs of different Spaces.



Clean sterilization, healthy life
Built-in coarse filter, PP filter screen, optional silver ion purification module, effectively remove large particles in the air, absorb formaldehyde and odor, eliminate germs.



Various forms of air outlets, matching with decoration
The indoor unit adopts a hidden installation mode, which can be equipped with appropriate air outlets to perfectly combine the air conditioning.



Specification

Model		CTVT-EDH71BX	CTVT-EDH80BX	CTVT-EDH90BX	CTVT-EDH100BX	CTVT-EDH112BX	CTVT-EDH140BX	CTVT-EDH220BX	CTVT-EDH280BX	CTVT-EDH450BX	CTVT-EDH560BX	
Static pressure	Standard	Pa	100	100	100	100	130	200	200	200	200	
	Range	Pa	50~130	50~130	50~130	50~130	50~130	100~300	100~300	100~300	100~300	
Cooling capacity	Capacity	Btu/h (W)	24000 (7100)	27000 (8000)	30000 (9000)	34000 (10000)	38000 (11200)	48000 (14000)	75000 (22000)	95500 (28000)	153500 (45000)	
	Input	W	280	280	420	420	420	420	1750	1750	2250	
Heating capacity	Capacity	Btu/h (W)	27000(8000)	30000(9000)	34000(10000)	38000(11200)	42000(12500)	55000(16000)	85300 (25000)	105772 (31000)	170600 (50000)	
	Input	W	280	280	420	420	420	420	1750	1750	2250	
Noise	H/M/L	dB(A)	50/48/46	50/48/46	53/51/49	53/51/49	53/51/49	53/51/49	55/53/51	55/53/51	61/58/56	
Design pressure		MPa	4.1	4.1	4.1	4.1	4.1	4.1	4.1	4.1	4.1	
Power supply			220-240V~/50Hz/60Hz									
Indoor air circulation (Cooling/Heating)	L/S		350	350	517	517	561	639	1250	1250	2083	
	m³/h		1260	1260	1860	1860	2020	2300	4500	4500	7500	
Connecting Pipe	Liquid	Inches	3/8"	3/8"	3/8"	3/8"	3/8"	3/8"	12.7mm	12.7mm	12.7mm	
	Gas	Inches	5/8"	5/8"	5/8"	5/8"	5/8"	5/8"	22.2mm	22.2mm	28.6mm	
Drainage Pipe		mm	25(ID20,OD25)				DN25					
Net dimensions	W x H x D	mm	850×380×590			1200×380×590			1366×758×470		1770×758×650	
Net weight		kg	49	49	58	58	58	58	120	120	220	
Packing dimensions	W x H x D	mm	1060×425×695			1410×435×695			1620×975×700		2010×975×910	
Gross weight		kg	55	55	64	64	64	64	145	145	245	
Loading Capacity			2.5HP	3.0HP	3.2HP	3.6HP	4.0HP	5.0HP	8.0HP	10.0HP	16.0HP	
Controller			Remote Controller & Wired controller									

Notes: 1. Specifications are based on the following conditions:
2. Cooling: Indoor temperature 27°C DB/19°C WB, and outdoor temperature 35°C DB/24°C WB.
3. Heating: Indoor temperature 20°C DB/15°C WB, and outdoor temperature 7°C DB/6°C WB.
4. Equivalent piping length: 5m; Level difference: 0m; Voltage: 230V.
5. Sound Level: Indoor unit sound pressure level, measured at a point 1.5m downward from the unit center.
6. Outdoor unit sound pressure level, measured at a point 1.0m in front of the unit.
7. Optional simple wired controller; Universal remote controller; auto-restart(optional); Timer: only one circle.
8. Due to ongoing product development, specifications are subject to change without notice.

Fresh Air Processing Unit



Recommended places
Cinemas, hotels, lobbies, dance halls, bars and other places

Technical characteristics



Healthy Fresh Air
Through the fresh air unit, the outdoor healthy air can be introduced into the room to keep the indoor healthy.



Ultra-high static pressure design
The maximum static pressure is 300pa, which can meet long-distance air supply and different space requirements.



Control Smart and Lower Cost
The fresh air unit can be controlled independently or connected to the same outdoor unit system with the AC indoor unit, reducing costs and installation space.



Simplify air exhaust system
Simplified air supply and exhaust system, stable and reliable.

Note: The sum of the capacity of the processing unit and the indoors should be 50%-100% of the ODU capacity, and the capacity of the fresh air units does not exceed 30%.

Specification

Model		CTVT-EFA155BX	CTVT-EFA224BX	CTVT-EFA280BX	CTVT-EFA450BX	CTVT-EFA560BX
Static pressure	Standard	Pa	196	200	200	300
	Range	Pa	50~130	50~130	50~130	50~130
Cooling capacity	Capacity	Btu/h (W)	48000(14000)	75000 (22400)	95500(28000)	153000(45000)
	Input	W	420	1100	1100	1550
Heating capacity	Capacity	Btu/h (W)	34000(10000)	54000 (16000)	68000(20000)	95500(28000)
	Input	W	420	1100	1100	1550
Noise	H/M/L	dB(A)	45	53	53	56
Design pressure		MPa	4.1	4.1	4.1	4.1
Power supply			220-240V~/50Hz/60Hz			
Indoor air circulation (Cooling/Heating)	L/S		569	833	833	1111
	m³/h		2050	3000	3000	4000
Connecting Pipe	Liquid	Inches	3/8"	1/2"	1/2"	1/2"
	Gas	Inches	5/8"	1"	1"	9/8"
Drainage Pipe		mm	25(ID20,OD25)			
Net dimensions	W x H x D	mm	1200×380×590	1366×470×758	1366×470×758	1770×650×758
Net weight		kg	58	120	120	220
Packing dimensions	W x H x D	mm	1410×435×695	1620×930×975	1620×930×975	2035×1170×975
Gross weight		kg	60	145	145	245
Loading Capacity			5HP	8HP	10HP	15HP
Controller			Remote Controller & Wired controller			

Notes: 1. Specifications are based on the following conditions:
2. Cooling: Indoor temperature 27°C DB/19°C WB, and outdoor temperature 35°C DB/24°C WB.
3. Heating: Indoor temperature 20°C DB/15°C WB, and outdoor temperature 7°C DB/6°C WB.
4. Equivalent piping length: 5m; Level difference: 0m; Voltage: 230V.
5. Sound Level: Indoor unit sound pressure level, measured at a point 1.5m downward from the unit center.
6. Outdoor unit sound pressure level, measured at a point 1.0m in front of the unit.
7. Optional simple wired controller; Universal remote controller; auto-restart(optional); Timer: only one circle.
8. Due to ongoing product development, specifications are subject to change without notice.



Wall-mounted



Recommended places

Living room, study, reference room, negotiation room and other places

Technical characteristics



Ultra-low silent operation

Adopt large-diameter blade, high-quality plastic-encapsulated motor, and the noise is as low as 27dB(A).



Ultra-thin body design, smart and beautiful

The minimum thickness of the unit is only 380mm, which makes installation more convenient.



Easy maintenance

The horizontal baffle of the unit is easy to remove for easy cleaning and maintenance.



Long-lasting filter design

The long-term filter design makes the air more healthy, reduces the difficulty of maintenance.



Wide-angle air supply, more comfortable

The upper and lower wind guide vanes make the airflow comfortable.



Specification

Model		CTVT-EHW22BX	CTVT-EHW28BX	CTVT-EHW36BX	CTVT-EHW45BX	CTVT-EHW50BX	CTVT-EHW56BX	CTVT-EHW71BX	CTVT-EHW80BX		
Control type		Remote Controller & Wired controller									
Cooling capacity	Capacity	W	2,200	2,800	3,600	4,500	5,000	5,600	7,100	8,000	
	Input	W	40	40	40	45	45	70	70	70	
	Current	A	0.19	0.19	0.19	0.2	0.2	0.32	0.32	0.32	
Heating capacity	Capacity	W	2,500	3,200	4,000	5,000	5,600	6,300	8,000	9,000	
	Input	W	40	40	40	45	45	70	70	70	
	Current	A	0.19	0.19	0.19	0.2	0.2	0.32	0.32	0.32	
Indoor noise level at cooling (sound pressure level)High/Med/Low			38/33/27	38/33/27	38/33/27	42/37/33	42/37/33	44/39/35	44/39/35	44/39/35	
Refrigerant type/Quantity		Type	R410A								
Design pressure		MPa	4.5	4.5	4.5	4.5	4.5	4.5	4.5	4.5	
Power supply			220-240V 1N ~ 50HZ								
Indoor air circulation (Cooling/Heating)		L/S	153	153	153	181	181	222	222	222	
		m ³ /h	550	550	550	650	650	800	800	800	
Indoor fan type			Centrifugal fan								
Connecting Pipe	Liquid	Inches	1/4"	1/4"	1/4"	1/4"	1/4"	3/8"	3/8"	3/8"	
	Gas	Inches	1/2"	1/2"	1/2"	1/2"	1/2"	5/8"	5/8"	5/8"	
Drainage Pipe		mm	16	16	16	16	16	16	16	16	
Net dimensions (W x H x D)		mm	910×294×206			1010×315×220					
Net weight		Indoor	kg	10	10	10	10	13	13	13	
Packing dimensions(W x H x D)		mm	977×367×276			1094×386×300					
Gross weight		Indoor	kg	12.5	12.5	12.5	12.5	16	16	16	
Loading Capacity			0.9HP	1.0HP	1.2HP	1.5HP	1.8HP	2.0HP	2.0HP	2.0HP	

Notes: 1. Specifications are based on the following conditions:
2. Cooling: Indoor temperature 27°C DB/19°C WB, and outdoor temperature 35°C DB/24°C WB.
3. Heating: Indoor temperature 20°C DB/15°C WB, and outdoor temperature 7°C DB/6°C WB.
4. Equivalent piping length:5m; Level difference:0m; Voltage:230V.

5. Sound Level: Indoor unit sound pressure level, measured at a point 1.5m downward from the unit center.
6. Outdoor unit sound pressure level, measured at a point 1.0m in front of the unit.
7. Optional simple wired controller; Universal remote controller; auto-restart(optional); Timer:only one circle.
8. Due to ongoing product development, specifications are subject to change without notice.

Ceiling & floor



Recommended places

Living room, study, reference room, negotiation room and other places

Technical characteristics



Ultra-thin Design

Compact design which fits for various room styles.



Wide Range of Air Flow

The air supply angle is from 0 to 110°, making the indoor temperature more uniform and more comfortable.



Dual Direction of Drainage

Condensing water can be drained both from left and right side.



Detachable Plastic Blowers

Universal design ed parts and assemblies applied, which is easy for maintenance.



Flexible Installation

Two ways of installation available, ceiling suspended and floor standing.



Wire Control (optional)

Wire control is available, especially for hotel rooms, offices, etc.

Specification

Model		CTVT-EFC45BX	CTVT-EFC50BX	CTVT-EFC56BX	CTVT-EFC63BX	CTVT-EFC71BX	CTVT-EFC80BX	CTVT-EFC90BX	CTVT-EFC100BX	CTVT-EFC112BX	CTVT-EFC125BX	CTVT-EFC140BX	
Cooling capacity	Capacity	Btu/h (W)	15000 (4500)	17000 (5000)	19000 (5600)	21000 (6300)	24000 (7100)	27000 (8000)	30000 (9000)	34000 (10000)	38000(11200)	42000 (12500)	48000 (14000)
	Input	W	102	102	102	149	149	149	158	158	235	235	235
Heating capacity	Capacity	Btu/h (W)	17000 (5000)	19000 (5600)	21000 (6300)	24000 (7100)	27000 (8000)	30000 (9000)	34000 (10000)	38000 (11200)	42000 (12500)	48000 (14000)	55000 (16000)
	Input	W	102	102	102	149	149	149	158	158	235	235	235
Noise	H/M/L	dB(A)	44/42/39	44/42/39	44/42/39	46/44/41	46/44/41	46/44/41	50/48/45	50/48/45	52/50/47	52/50/47	52/50/47
Design pressure	MPa	4.1	4.1	4.1	4.1	4.1	4.1	4.1	4.1	4.1	4.1	4.1	
Power supply		220-240V~/50Hz/											
Indoor air circulation (Cooling/Heating)	L/S	267	267	267	333	333	333	444	444	556	556	556	
	m ³ /h	960	960	960	1200	1200	1200	1600	1600	2000	2000	2000	
Connecting Pipe	Liquid	Inches	1/4"	1/4"	1/4"	3/8"	3/8"	3/8"	3/8"	3/8"	3/8"	3/8"	
	Gas	Inches	1/2"	1/2"	1/2"	5/8"	5/8"	5/8"	5/8"	5/8"	5/8"	5/8"	
Drainage Pipe	mm	25(ID20,OD25)											
Net dimensions	W x H x D	1055×675×235			1275×675×235			1635×675×235					
	Net weight	kg	24	24	24	25	25	25	29	29	38	38	38
Packing dimensions	W x H x D	1131×753×313			1351×753×313			1711×753×313					
	Gross weight	kg	27	27	27	28	28	28	35	35	46	46	46
Loading Capacity		1.5HP	1.8HP	2.0HP	2.2HP	2.5HP	3.0HP	3.2HP	3.6HP	4.0HP	4.5HP	5.0HP	
Controller		Remote Controller & Wired controller											

Notes: 1. Specifications are based on the following conditions:
2. Cooling: Indoor temperature 27°C DB/19°C WB, and outdoor temperature 35°C DB/24°C WB.
3. Heating: Indoor temperature 20°C DB/15°C WB, and outdoor temperature 7°C DB/6°C WB.
4. Equivalent piping length:5m; Level difference:0m; Voltage:230V.

5. Sound Level: Indoor unit sound pressure level, measured at a point 1.5m downward from the unit center.
6. Outdoor unit sound pressure level, measured at a point 1.0m in front of the unit.
7. Optional simple wired controller; Universal remote controller; auto-restart(optional); Timer:only one circle.
8. Due to ongoing product development, specifications are subject to change without notice.



One-way Cassette



Recommended places

Living room, dining room, office, lobby, etc

Technical characteristics



High-lift Drain Pump

The drain pump with a 700mm lifting head which is as standard, simplifying installation of the drain pipes.



Standard float switch, real-time monitor water level

Equipped with float switch, which will automatically monitor the water level and send alarm when malfunction of drain pump or stuck of drain pipe occurs.



Wide-angle air flow

Adopting new type of swing motor, which largely increases the angle of air flow.



High ceiling design

Reserves a super high fan speed for high ceiling installation, unit can provide powerful cooling and heating under a more than 3 meters floor height.



Slim body

Super slim body with 235mm thickness, less installation area required, capable to match multiple decoration styles.



Suitable for corner installation, comfortable air flow

Well-designed shape, suitable for corner installation, make sure the air flow and temperature distribution well.



Three level fan speeds

High, Mid, Low three fan speed options, can meet the needs of different indoor condition.

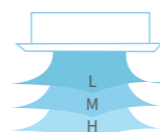

Two-way Cassette



Recommended places

Sitting room, study, dining room, small meeting room, etc

Technical characteristics



High-lift Drain Pump

A drain pump with a 700mm raise height is fitted as standard, simplifying installation of the drain piping.



Standard float switch, water level monitor

Equipped with float switch, which will automatically send alarm when malfunction of drain pump or stuck of drain pipe occur.



Three - speed adjustment

New winding motor, with scroll fan technology, wider air volume regulation, quieter operation, unique intimate wind gear design. High, medium and low three speed adjustment, strong refrigeration and heating, to create a quiet and comfortable temperature.



Ultra-thin body, lightweight design

Ultra-thin body (290mm), requires less installation space, even in the narrow low ceiling, still can be easily installed, more flexible collocation decoration style.



Super wide Angle air supply

Panel swing motor system adopts high-precision stepper motor, panel up and down risk control system is more intelligent, to achieve ultra-wide Angle and large range of air supply.



Quiet design, quiet and comfortable

Centrifugal wind wheel, axial air inlet, through rotation to form a certain wind pressure, small blade area, large number, uniform air, noise greatly reduced, for you to create a quiet and comfortable environment.



High ceiling design, direct air flow to the ground

High ceiling design, suitable for ceiling height up to 3m space.

IDU parameters

Model		CTVT-ECS18BX	CTVT-ECS22BX	CTVT-ECS28BX	CTVT-ECS36BX	CTVT-ECS45BX	CTVT-ECS50BX	CTVT-ECS56BX	
Control type		Remote Controller & Wired controller							
Cooling capacity	Capacity	W	1,800	2,200	2,800	3,600	4,500	5,000	5,600
	Input	W	50	50	50	60	70	70	70
	Current	A	0.24	0.24	0.24	0.28	0.31	0.31	0.31
Heating capacity	Capacity	W	2,200	2,500	3,200	4,000	5,000	5,600	6,300
	Input	W	50	50	50	60	70	70	70
	Current	A	0.24	0.24	0.24	0.28	0.31	0.31	0.31
Indoor noise level at cooling(sound pressure level) High/Med/Low	dB(A)	39/34/31	39/34/31	39/34/31	40/34/31	42/36/33	42/36/33	42/36/33	42/36/33
Refrigerant type/Quantity	Type	R410A							
Design pressure	MPa	4.5	4.5	4.5	4.5	4.5	4.5	4.5	
Power supply		220-240V~/50Hz							
Indoor air circulation (Cooling/Heating)	L/S	142	142	142	189	222	222	222	
	m ³ /h	510	510	510	680	800	800	800	
Indoor fan type		Centrifugal fan							
Connecting Pipe	Liquid	Inches	1/4"	1/4"	1/4"	1/4"	1/4"	1/4"	
	Gas	Inches	3/8"	3/8"	3/8"	1/2"	1/2"	1/2"	
Drainage Pipe	mm	25(ID25,OD32)							
Net dimensions (W x H x D)	mm	850×480×235							
Net weight	Indoor	kg							
Packing dimensions (W x H x D)	mm	1105×645×305							
Gross weight	Indoor	kg							
Loading Capacity		0.7HP	0.9HP	1.0HP	1.2HP	1.5HP	1.8HP	2.0HP	

Notes: 1. Specifications are based on the following conditions:

- Cooling: Indoor temperature 27°C DB/19°C WB, and outdoor temperature 35°C DB/24°C WB.
- Heating: Indoor temperature 20°C DB/15°C WB, and outdoor temperature 7°C DB/6°C WB.
- Equivalent piping length: 5m; Level difference: 0m; Voltage: 230V.

5. Sound Level: Indoor unit sound pressure level, measured at a point 1.5m downward from the unit center.

- Outdoor unit sound pressure level, measured at a point 1.0m in front of the unit.
- Optional simple wired controller; Universal remote controller; auto-restart(optional); Timer: only one circle.
- Due to ongoing product development, specifications are subject to change without notice.

IDU parameters

Model		CTVT-ECD22BX	CTVT-ECD28BX	CTVT-ECD36BX	CTVT-ECD45BX	CTVT-ECD50BX	CTVT-ECD56BX	CTVT-ECD63BX	CTVT-ECD71BX	
Control type		Remote Controller & Wired controller								
Cooling capacity	Capacity	W	2,200	2,800	3,600	4,500	5,000	5,600	6,300	7,100
	Input	W	64	64	70	70	70	70	110	110
	Current	A	0.27	0.27	0.31	0.31	0.31	0.31	0.49	0.49
Heating capacity	Capacity	W	2,500	3,200	4,000	5,000	5,600	6,300	7,100	8,000
	Input	W	64	64	70	70	70	70	110	110
	Current	A	0.27	0.27	0.31	0.31	0.31	0.31	0.49	0.49
Indoor noise level at cooling(sound pressure level) High/Med/Low	High/Med/Low	40/35/32	42/36/33	43/38/35	43/38/35	43/38/35	43/38/35	43/38/35	46/39/36	46/39/36
Refrigerant type/Quantity	Type	R410A								
Design pressure	MPa	4.5	4.5	4.5	4.5	4.5	4.5	4.5	4.5	
Power supply		220-240V~/50Hz								
Indoor air circulation (Cooling/Heating)	L/S	161	161	189	189	236	236	378	378	
	m ³ /h	580	580	680	680	850	850	1360	1360	
Indoor fan type		Centrifugal fan								
Connecting Pipe	Liquid	Inches	1/4"	1/4"	1/4"	1/4"	1/4"	1/4"	3/8"	3/8"
	Gas	Inches	1/2"	1/2"	1/2"	1/2"	1/2"	1/2"	5/8"	5/8"
Drainage Pipe	mm	25(ID25,OD32)	25(ID25,OD32)	25(ID25,OD32)	25(ID25,OD32)	25(ID25,OD32)	25(ID25,OD32)	25(ID25,OD32)	25(ID25,OD32)	
Net dimensions (W x H x D)	mm	1140×575×290	1140×575×290	1140×575×290	1140×575×290	1140×575×290	1140×575×290	1140×575×290	1140×575×290	
Net weight	Indoor	kg	32	32	33	33	33	34	34	
Packing dimensions (W x H x D)	mm	1305×755×370								
Gross weight	Indoor	kg	38	38	39	39	39	40	40	
Loading Capacity		0.9HP	1.0HP	1.2HP	1.5HP	1.8HP	2.0HP	2.2HP	2.5HP	

Notes: 1. Specifications are based on the following conditions:

- Cooling: Indoor temperature 27°C DB/19°C WB, and outdoor temperature 35°C DB/24°C WB.
- Heating: Indoor temperature 20°C DB/15°C WB, and outdoor temperature 7°C DB/6°C WB.
- Equivalent piping length: 5m; Level difference: 0m; Voltage: 230V.

5. Sound Level: Indoor unit sound pressure level, measured at a point 1.5m downward from the unit center.

- Outdoor unit sound pressure level, measured at a point 1.0m in front of the unit.
- Optional simple wired controller; Universal remote controller; auto-restart(optional); Timer: only one circle.
- Due to ongoing product development, specifications are subject to change without notice.



Location of refrigerant pipes

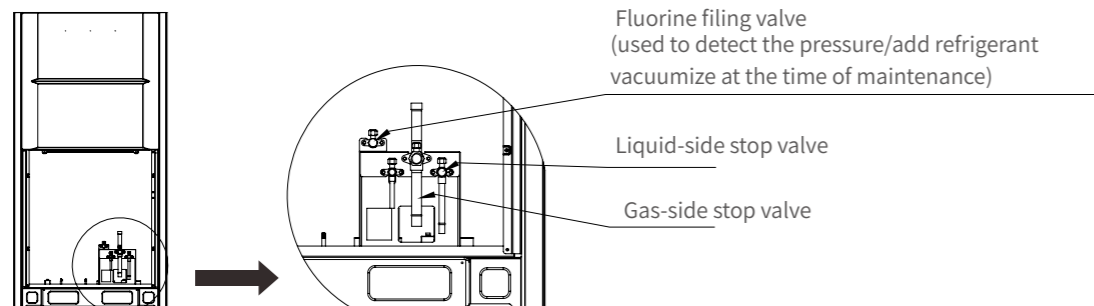

Installation space for ODU

- The space shown in the figure needs to be reserved for the installation of the ODU, and the power supply equipment should be installed separately.

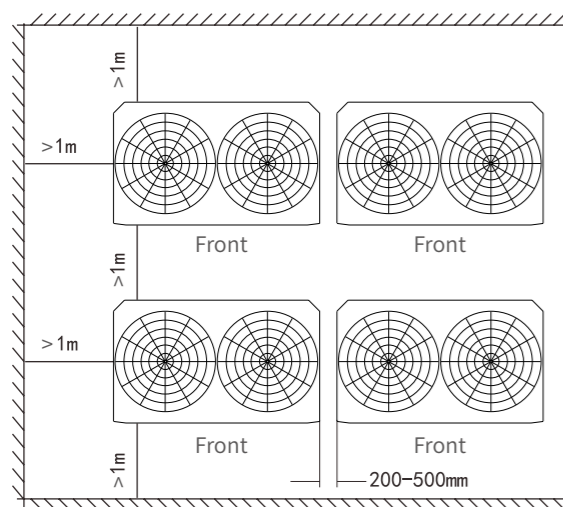

- To ensure the heat dissipation of the outdoor unit, there should be no obstacles above the outdoor unit. If it cannot be avoided, a deflector should be installed.

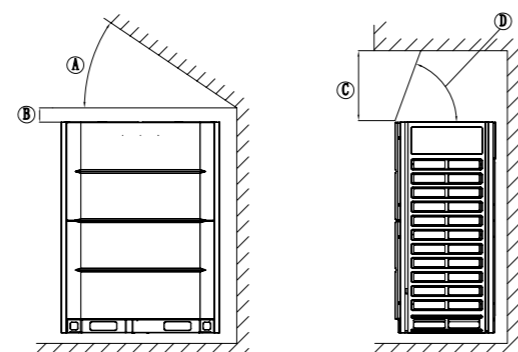

- A More than 45°
- B More than 300mm
- C More than 1000mm
- D Guide plate

- If there are stacks around the outdoor unit, the height should be less than 800mm from the top of the outdoor unit. If it is less than the size, a mechanical exhaust device must be installed.

Arrangement sequence of ODU

- When a system has more than two outdoor units, it is necessary to install the units as the followings: The outdoor units are arranged in descending order (for example, in the right picture, ODU capacity A ≥ ODU capacity B ≥ ODU capacity C) and the ODU A should install at the brance pipe.

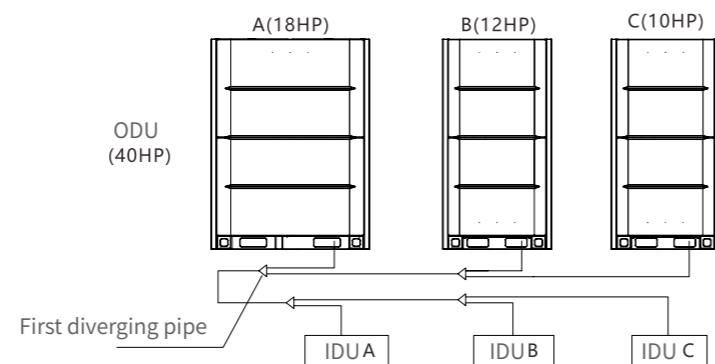

Dimension of ODU

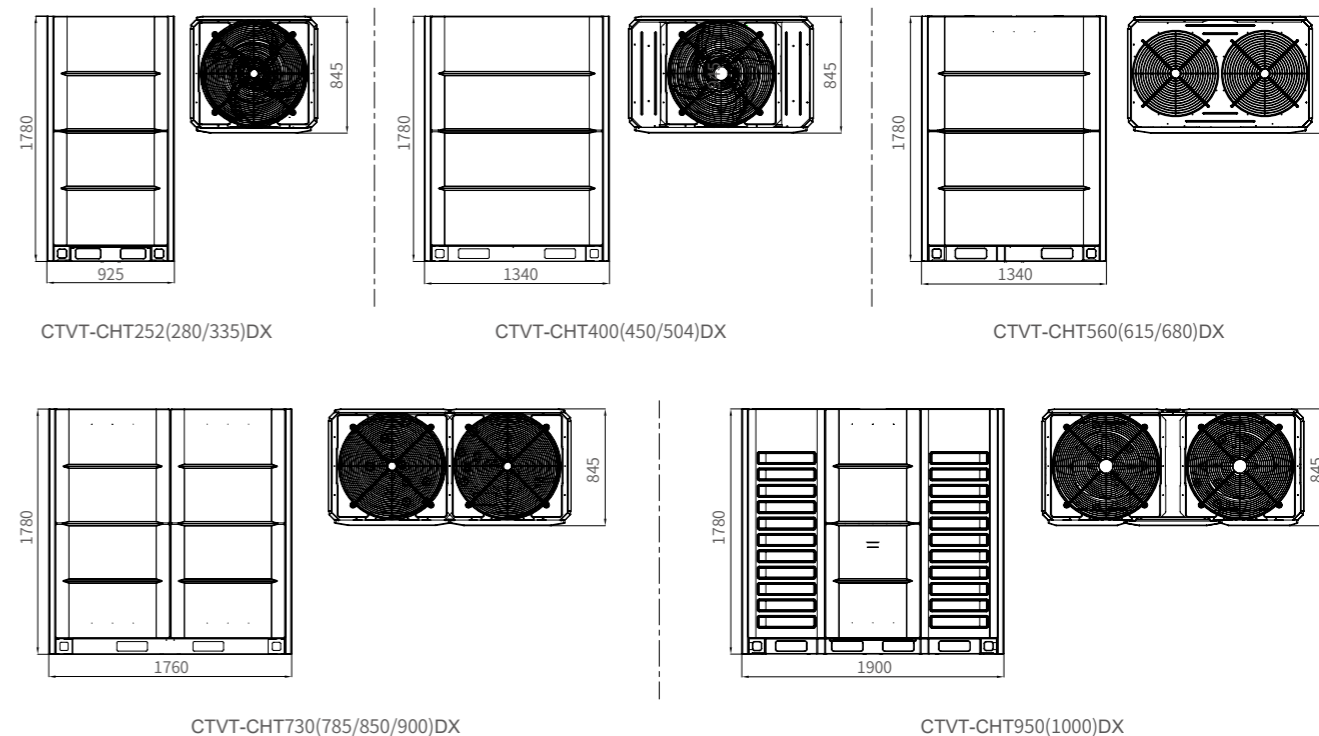

Requirements for ODU installation

- A shock absorber or shock pad should be installed between the unit and the foundation.
- The unit and the foundation should be released tightly, otherwise there will be a lot of noise and vibration.
- The outdoor unit must be grounded reliably.
- It is forbidden to open the valves of the liquid pipe, gas pipe and oil balance pipe of the unit before commission.
- The installation should ensure that there is enough space for maintenance.

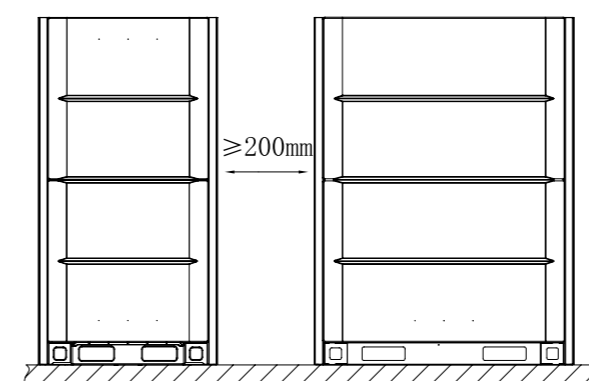

Model	A	B
CTVT-CHT252(280/335)DX	724	725
CTVT-CHT400(450/504)DX	1141	725
CTVT-CHT560(615/680)DX	1141	725
CTVT-CHT730(785/850/900)DX	1561	725
CTVT-CHT950(1000)DX	1700	725



Design of refrigerant piping

Refrigerant pipe length and height

		Admissible value	Pipes
Length of supporting pipe	Total length of Refrigerant pipes (Total extended length)	1100m	$L1+(L2+L3+L4+L5+L6+L7+L8+L9+L10+L11+L12) \times 2+a+b+c+d+e+f+g+h+i+j+k+l+m$
	Length of the farthest supporting pipe(L)	True length	220m
		Equivalent length	240m
Length of the supporting pipe furthest from the first branch pipe(L)*		120m	$L7+L8+L9+L10+i$
Height	Height difference between indoor and outdoor units (H)	ODU up	100m
		ODU down	110m
	Height between indoor units (h)		40m

* Note: Refer to relevant technical documents or consult technical person

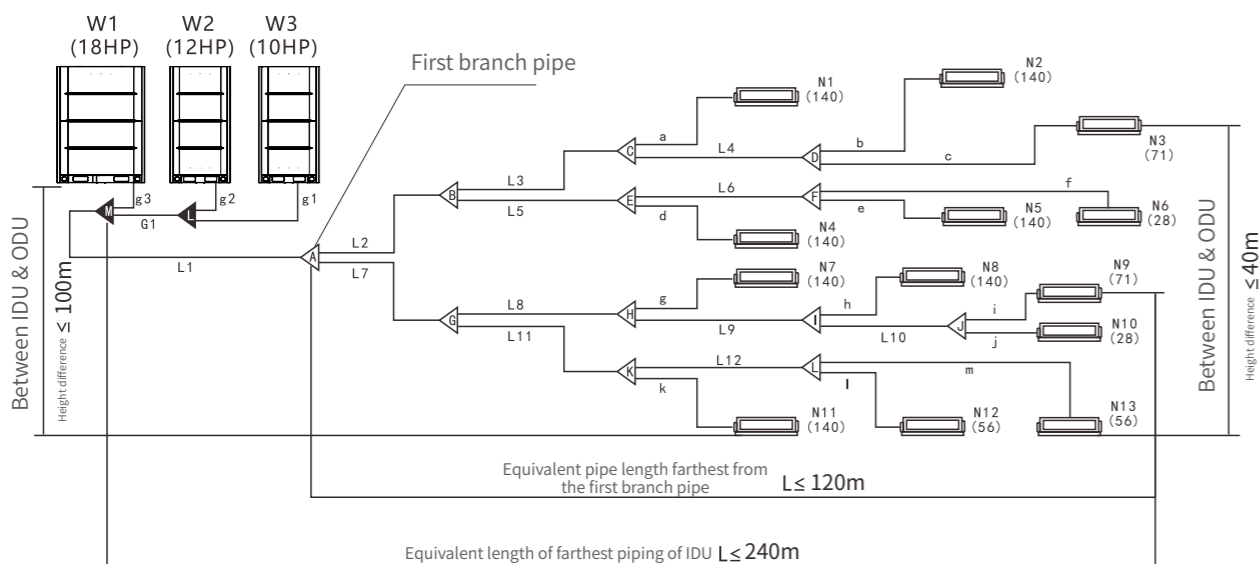

Branch pipe specifications

Assembly	Include parts	Assembly	Include parts
CTVT-BY01 Branch pipe parts	G01、L01	CTVT-BY05 Branch pipe parts	G04、L03
CTVT-BY02 Branch pipe parts	G02、L01	CTVT-BY06 Branch pipe parts	L01、L01
CTVT-BY03 Branch pipe parts	G02、L02	CTVT-BY07 Branch pipe parts	L01、L02
CTVT-BY04 Branch pipe parts	G03、L02	CTVT-BY08 Branch pipe parts	G05、G02

Branch pipe specifications

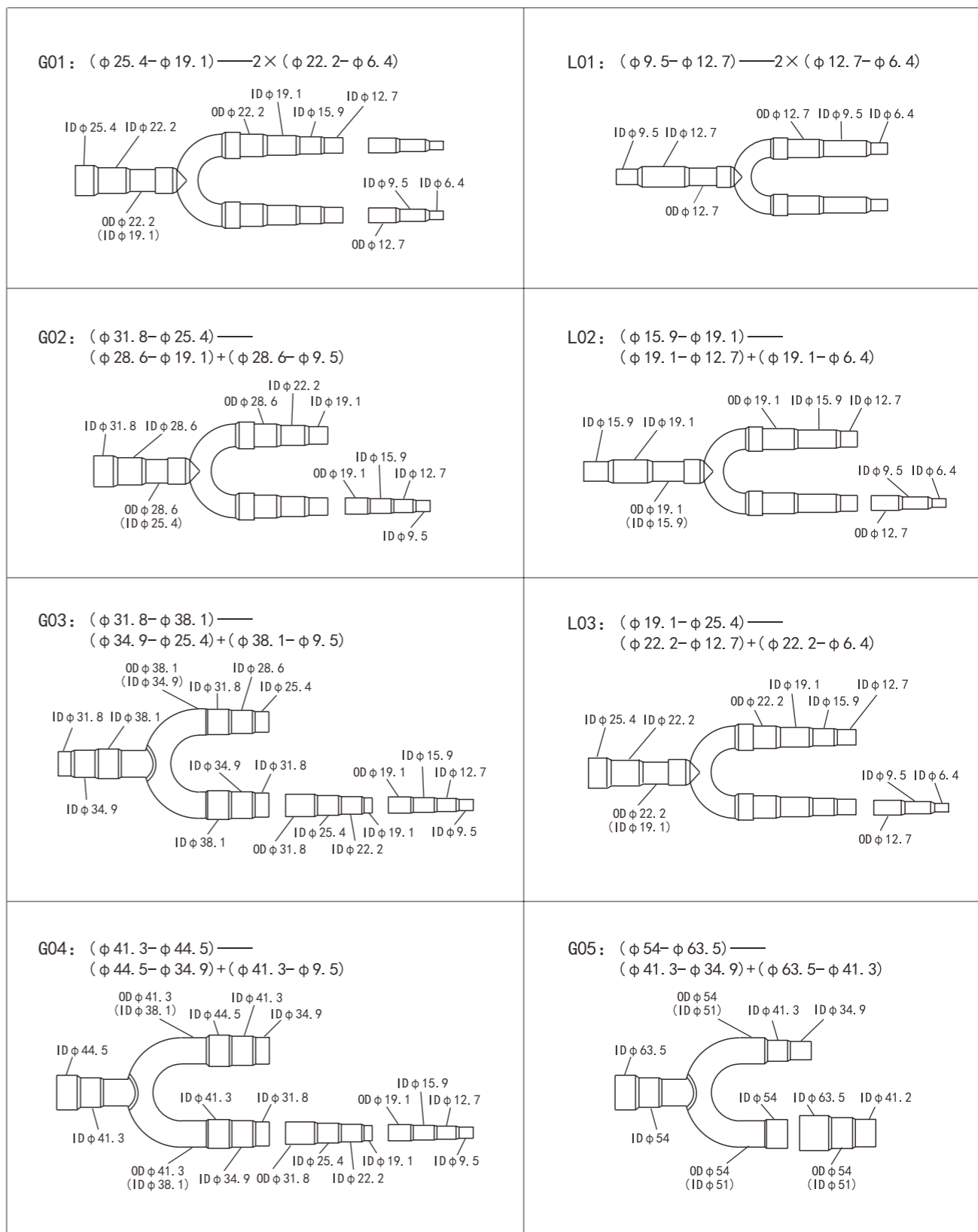



Piping classification

Allowable length and height difference of refrigerant piping

Name of supporting pipe	Connection position of supporting pipe	Assembly
Main pipe	Pipe between the outdoor unit and the first branch	L1
Main pipe of indoor unit	Pipe behind the first indoor branch which do not connect to indoor unit	L2,L3,L4,... L12
Slave pipe of indoor unit	Pipes between the branch and indoor unit	a,b, c, d,... m
Indoor unit branch assembly	Pipes to the master pipe and slave pipes	A, B, C,D,E,F,G,H, I,J,K,L
Outdoor unit branch assembly	Pipes to the outdoor unit and main pipe	L,Mg
Outdoor unit connecting pipe	Pipe between outdoor and outdoor branch	1,g2, g3, g4, G1, G2

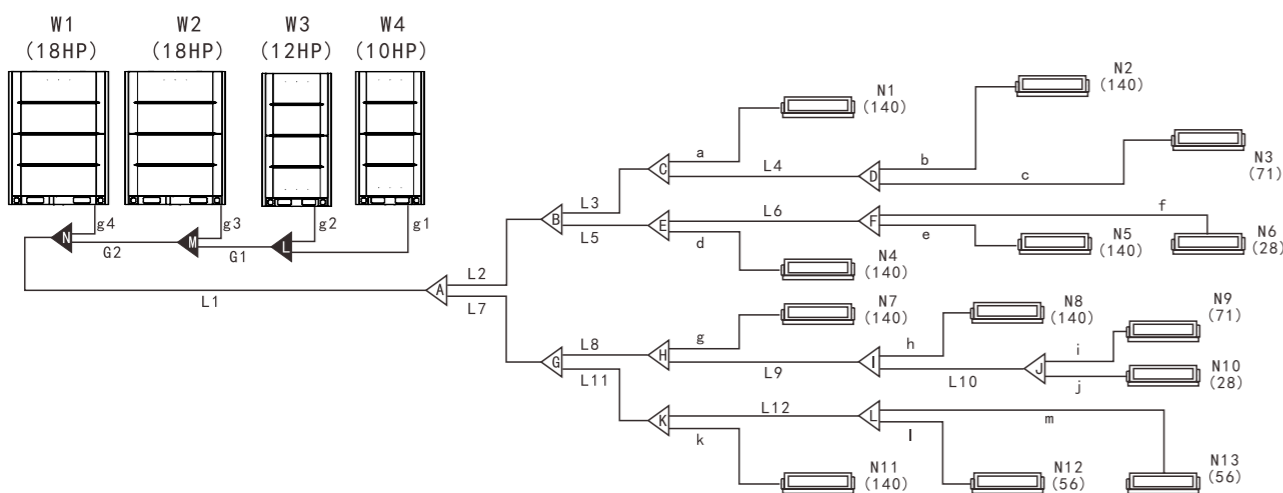

Pipe dimension of indoor unit(NO.: a,b,c,d,... m)

Indoor Unit Model	Gas side	Liquid side
Capacity: 1800~2200W	φ9.52 (flared nut)	φ6.35 (flared nut)
Capacity: 2800~5600W	φ12.7 (flared nut)	φ6.35 (flared nut)
Capacity: 6300~14000W	φ15.9 (flared nut)	φ9.52 (flared nut)

IDU main piping and branch pipe assembly(Number: L2,L3,L4...L12,A,B,C...L)

Capacity of downstream Indoor unit A(×100w)	Dimension of Master pipe (Gas/Liquid)	Applicable brance pipe (Gas/Liquid)	A(×100w)	Dimension of master pipe (Gas/Liquid)	Applicable brance pipe (Gas/Liquid)
A < 63	φ12.7/φ6.35	CTVT-BY06(L01/L01)	63 ≤ A < 168	φ15.9/φ9.52	BY07(L02/L01)
168 ≤ A < 224	φ19.1/φ9.5	CTVT-BY07(L02/L01)	224 ≤ A < 330	φ22.2/φ12.7	BY01(G01/L01)
330 ≤ A < 470	φ25.4/φ12.7	CTVT-BY01(G01/L01)	470 ≤ A < 710	φ28.6/φ15.9	BY03(G02/L02)
710 ≤ A < 1040	φ31.8/φ19.1	CTVT-BY03(G02/L02)	1040 ≤ A < 1540	φ38.1/φ19.1	BY04(G03/L02)
1540 ≤ A < 1800	φ41.2/φ22.2	CTVT-BY05(G04/L02)	1800 ≤ A < 2500	φ44.5/φ25.4	BY05(G04/L03)
2500 ≤ A	φ54.0/φ28.6	CTVT-BY08(G05/G02)			

Diameter of outer connecting pipe

ODU stop valve port diameter(Number: g1,g2,g3,g4)

Model	Gas	Liquid
CTVT-CHT252(280/335/400)DX	φ25.4 (welding)	φ12.7 (welding)
CTVT-CHT450(504/560/615/680)DX	φ28.6 (welding)	φ15.8 (welding)
CTVT-CHT730(785/850/900)DX	φ31.8 (welding)	φ19.1 (welding)
CTVT-CHT950(1000)DX	φ34.9 (welding)	φ19.1 (welding)

ODU Main pipe and branch pipes

Capacity of Outdoor unit	Main equivalent length of all piping less than 90m		Main equivalent pipe length more than 90m	
	Gas pipe/Liquid pipe	First branch of indoor unit (Gas side/Liquid side)	Gas pipe/liquide pipe	First branch of indoor unit (Gas side/Liquid side)
8 ~ 12HP	φ25.4/φ12.7	CTVT-BY01 Prats (G01/L01)	φ28.6/φ12.7	CTCT-BY02 Prats (G02/L01)
14 ~ 16HP	φ28.6/φ12.7	CTVT-BY02 Prats (G02/L01)	φ28.6/φ15.9	CTVT-BY03 Prats (G02/L02)
18 ~ 24HP	φ28.6/φ15.9	CTVT-BY03 Prats (G02/L02)	φ31.8/φ19.1	CTVT-BY03 Prats (G02/L02)
26 ~ 32HP	φ31.8/φ19.1	CTVT-BY03 Prats (G02/L02)	φ34.9/φ19.1	CTVT-BY04 Prats (G03/L02)
34 ~ 36HP	φ34.9/φ19.1	CTVT-BY04 Prats (G03/L02)	φ38.1/φ22.2	CTVT-BY04 Prats (G03/L02)
38 ~ 42HP	φ34.9/φ19.1	CTVT-BY04 Prats (G03/L02)	φ38.1/φ22.2	CTVT-BY04 Prats (G03/L02)
44 ~ 48HP	φ38.1/φ19.1	CTVT-BY04 Prats (G03/L02)	φ41.2/φ22.2	CTVT-BY05 Prats (G04/L03)
50 ~ 54HP	φ38.1/φ19.1	CTVT-BY04 Prats (G03/L02)	φ41.2/φ22.2	CTVT-BY05 Prats (G04/L03)
56 ~ 66HP	φ41.2/φ22.2	CTVT-BY05 Prats (G04/L03)	φ44.5/φ22.2	CTVT-BY05 Prats (G04/L03)
68 ~ 72HP	φ41.2/φ22.2	CTVT-BY05 Prats (G04/L03)	φ44.5/φ25.4	CTVT-BY05 Prats (G04/L03)
74 ~ 84HP	φ44.5/φ22.2	CTVT-BY05 Prats (G04/L03)	φ50.8/φ25.4	CTVT-BY08 Prats (G05/G02)
86 ~ 96HP	φ50.8/φ25.4	CTVT-BY08 Prats (G05/G02)	φ54.0/φ28.6	CTVT-BY08 Prats (G05/G02)
98 ~ 108HP	φ54.0/φ28.6	CTVT-BY08 Prats (G05/G02)	φ63.0/φ28.6	CTVT-BY08 Prats (G05/G02)

Remark:

- Please select the main pipe diameter of the outdoor unit follow the above table. If the main pipe is larger, choose the main pipe according to larger one.
- If the system is more than 108HP, please consult technical personnel.



Electrical system and installation

Electrical wiring precautions

- Please design the dedicated power supply for IDU and ODU separately.
- The power supply should be equipped with a leakage protector and a manual switch.
- The power supply, leakage protector and manual switch of the IDU connected to the same ODU are required to be universal. (Please use the same circuit for the IDU power supply of the same system. And it must be turned on and off at the same time, otherwise it will seriously affect the service life of the system, and unpredictable situations may occur.)
- Please integrate the IDU and ODU connection wiring system and refrigerant piping system into the same system.
- In order to reduce interference, it is recommended to use two-core shielded cables for the signal cables of the IDU and ODU. Please do not use multi-core cables without shielding.
- During installation, the communication line and the power line must not be intertwined, and must be routed separately, and the minimum distance should be greater than 20CM, otherwise the communication of the unit may be abnormal.
- Power wiring must be entrusted to professional electricians.

ODU power wiring

Model	Power supply	Minimum wire diameter current (A)	Copper core PVC insulated wire BVV(mm ²)	Copper core XLPE insulated wire YJV(mm ²)	Manual switch (A) capacity	Leakage protector
CTVT-CHT250DX	380V 3N ~ 50Hz	19.5	4.0X5	4.0X5	32	< 100mA 0.1sec
CTVT-CHT280DX	380V 3N ~ 50Hz	21.6	4.0X5	4.0X5	32	
CTVT-CHT330DX	380V 3N ~ 50Hz	24.9	6.0X5	4.0X5	32	
CTVT-CHT400DX	380V 3N ~ 50Hz	26.5	6.0X5	4.0X5	32	
CTVT-CHT450DX	380V 3N ~ 50Hz	32.2	10.0X5	6.0X5	40	
CTVT-CHT500DX	380V 3N ~ 50Hz	34.0	10.0X5	6.0X5	40	
CTVT-CHT560DX	380V 3N ~ 50Hz	41.8	16.0X5	10.0X5	50	
CTVT-CHT615DX	380V 3N ~ 50Hz	42.9	16.0X5	10.0X5	50	
CTVT-CHT680DX	380V 3N ~ 50Hz	45.5	16.0X5	10.0X5	50	
CTVT-CHT730DX	380V 3N ~ 50Hz	46.0	16.0X5	10.0X5	50	
CTVT-CHT785DX	380V 3N ~ 50Hz	48.0	16.0X5	10.0X5	50	
CTVT-CHT850DX	380V 3N ~ 50Hz	56.8	25.0X3+16.0X2	16.0X5	63	
CTVT-CHT900DX	380V 3N ~ 50Hz	57.0	25.0X3+16.0X2	16.0X5	63	
CTVT-CHT950DX	380V 3N ~ 50Hz	63.8	25.0X3+16.0X2	16.0X5	80	
CTVT-CHT1000DX	380V 3N ~ 50Hz	64.0	25.0X3+16.0X2	16.0X5	80	

Remark : 1.The wire diameter and continuous length in the table are applicable to a maximum distance of 20 meters. If the power wiring exceeds 20 meters and the voltage drop exceeds the range of 2%, please choose a wire diameter with a larger cross-sectional area.
2.The selection of the power cord is based on the ambient temperature of 40° C.
3.The wire current carrying capacity in the attached table is only for the user's reference. The actual interception capacity of the wire varies depending on the type and length of the cable, the way of pipe penetration, and the actual laying environment, and the correction factor is different.

ODU power connection

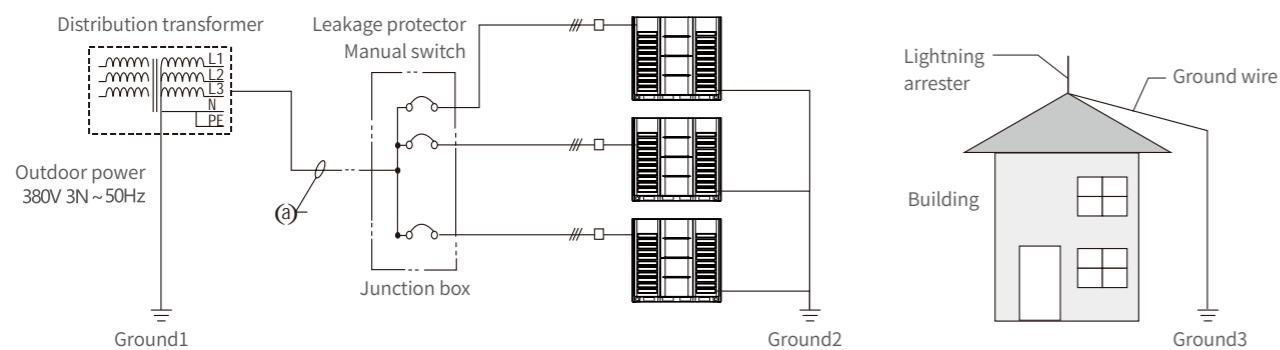

IDU power wiring

Model	Power supply	Minimum wire diameter(mm ²)			Manual switch		Leakage protector
		Dimensions (Continuous Length)	Dimensions (Continuous Length)	Ground wire	Capacity	Fuse	
All IDU Model	90-140Q8 125-140F2 125-140F5 Other model	380V ~ 3N50Hz 220V ~1N 50Hz	2.5 (30m)	4.0 (50m)	φ1.6mm	30 15	20A, 30mA < 0.1sec

Remarks: The wiring diameter and continuous length in the table indicate that the voltage drop is within 2%. When the continuous wiring length exceeds the value in the table, please follow the relevant regulations to select the wire diameter.

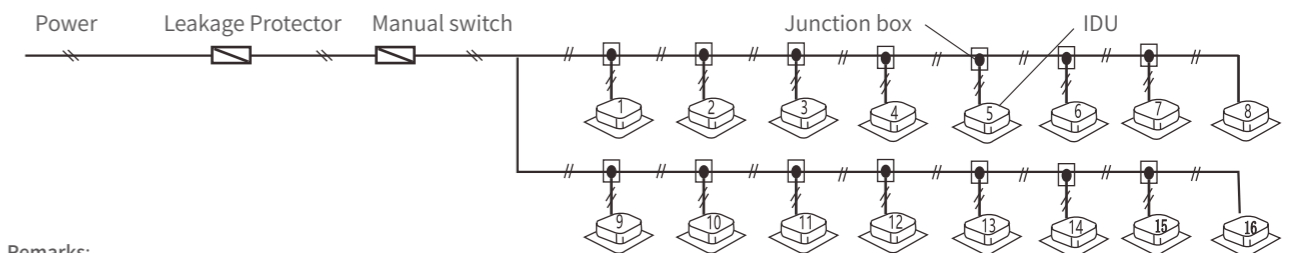

Remarks:

1. Please use the refrigerant piping system, the indoor unit-indoor unit room, and the indoor unit-outdoor unit connection signal line as the same system.
2. All the internal units in the same system must be powered in a unified manner, and some internal units cannot be cut off, otherwise the unit will fail.
3. When the power cable and the signal cable are parallel, please put the wires into their respective wire ducts, and leave a suitable distance between the wires. (Distance between power cables: 300mm below 10A, 500mm below 50A)
4. When multiple outdoor units are connected in parallel, the main outdoor unit must be set. (Refer to the settings of the DIP switch)

Control system and installation

- Signal lines must be shielded. Using other wires may cause signal interference and cause malfunction.
- The shielding nets of all shielded wires are connected to each other and finally connected to the sheet metal ground at one point.
- It is forbidden to bundle signal wires, refrigerant pipes, power wires, etc. together. When the power line and the signal line are laid in parallel, they should be kept at a distance of more than 300mm to prevent the signal source from being disturbed.
- Signal lines cannot form a closed loop.
- The signal line has no polarity, and there is no need to distinguish it when wiring.

IDU and ODU signal line wiring

- Please use two-core shielded wire ($\geq 0.75\text{mm}^2$) for the signal cable of indoor and outdoor units, without polarity. The signal cable of indoor and outdoor units should be connected as far as possible from the end of the outdoor unit.

